

A note to our customers, parts managers and dealers:

This manual has been prepared to assist you in the proper use, daily care, and operation of your new Krause equipment. It contains specific information on the many built-in features of your equipment, the accessories and options that are available, general specifications, and instructions for making minor adjustments.

Read this manual carefully before operating your Krause equipment, and keep it in a convenient location for later reference.

In order to ensure that you have the most current owner's manual available for your implement, we have added a revision code to each manual. Please note the information listed below and specify when placing service calls or ordering parts.

Manual for Model: TL 6200

This manual covers models beginning with Serial No. 1001

Owner's Manual #: 6200-1

Parts Manual #: 6200-2

Rev.:

ISSUED TO:

ISSUED BY:

Owner's Name

Krause Dealer

Mailing Address

City

City

State

State

Date of Purchase

Warranty Policy

(Krause Serial Numbered Wholegoods purchased subsequent to May 1, 2008)

Note: This warranty is limited to the equipment and parts sold in North America and all warranty work must be accomplished by a Krause Corporation Authorized Service Center rated to perform maintenance on Krause Corporation Products.

A. KRAUSE CORPORATION (“KRAUSE”) LIMITED WARRANTY.

- (1) Subject to the limitations and conditions hereinafter set forth, Krause warrants, at the time of delivery by Krause to be free from (i) defects in materials or workmanship, and (ii) defects in design that in the view of the state of the art as of the date of manufacture should have been foreseen provided, however, that the defect must be discovered and reported to Krause within the periods specified as follows. For a period of one year all new serial numbered production agricultural units covered by this warranty; for a period of thirty-six (36) months the tongue weldment, center frame weldment, wing frame weldments, disc harrow gang bearings and K-Tine field cultivator shanks.
- (2) Krause does not warrant disc blades, shanks, hydraulic cylinders, accessories and other parts not manufactured by it, but supplied with or as a part of its products. Krause will, however, obtain and pass on any adjustments provided by the manufacturers of such parts under these manufacturer's warranties. Tires supplied on Krause products, will be warranted by the tire manufacturer's retail outlets.
- (3) The entire extent of Krause's liability shall be limited to that of either reimbursing Buyer for its costs of purchasing a rebuilt, over-hauled or repaired part from either Krause or a proper Krause Authorized Service Center or, at Krause's election, reimbursing buyer for its costs of having the part repaired at a proper Krause Authorized Service Center. If Krause elects not to repair the part and if neither a rebuilt, over-hauled or repaired part is, in Krause's opinion, timely available then Krause will reimburse buyer for its costs of purchasing a new part from either Krause or a proper Krause Authorized Service Center. The labor necessary to remove from the product such part or parts and to install in the product such part or parts, as well as any repair made as the result of improper installations by Krause, shall be covered by this warranty, provided the work is performed at a proper Krause Authorized Service Center.★ If return of the defective part is required, it must be returned shipping prepaid to Krause. Krause's limited warranty will apply to any part repaired or replaced by a proper Krause Authorized Service Center pursuant to Krause's Limited Warranty: however, the applicable warranty for such part repaired or replaced shall be limited to the unexpired portion of Krause's Limited Warranty described in paragraph (1) or (2) above, as applicable. In other words, the warranty period of the part repaired or replaced does not start over from the date of reinstallation.

★[Krause Corporation will repair or replace, free of charge, any part of the product found to be defective, within the specified warranty periods, after an inspection of the part has deemed it to be defective. Inspection must be performed by an authorized agent of Krause Corporation, or returned to the Krause factory for inspection and disposition. Warranty labor will be considered during the first year of warranty only. Krause Corporation will establish and publish an hourly flat rate for shop labor and reimbursement during the first year of the warranty period. Krause Corporation does not allow credit for the cost of travel time, mileage or hauling as a warranty allowance. During the remaining second and third year, when applicable, Krause will repair or replace the defective part, without consideration of labor charges.]

- (4) Routine services (such as inspections, field settings, adjustments, etc.) and replacement of items which deteriorate from expected normal wear and tear or exposure (such as paint, tires, hoses, blades, sweeps, etc.) are not covered by this Limited Warranty. Such routine services and replacements required during the course of operation are not considered to be the result of any defect in the product.

B. LIMITATIONS APPLICABLE TO KRAUSE'S LIMITED WARRANTY.

- (1) This Warranty Policy only applies to equipment and parts sold in North America. Krause will be relieved of all obligations and liability under this warranty if:
 - (i) The alleged defect in the part is due to misuse or neglect on the part of someone other than Krause; or
 - (ii) Krause's identification mark or name or serial number has been removed from the part in question; or
 - (iii) The product and/or equipment have not been maintained, operated or stored either in accordance with applicable manuals, communications or other written instructions of Krause or any manufacturer of the part involved, or in accordance with applicable regulations and advisory circulars unless buyer shows that such maintenance, operation or storage was not a contributory cause of the defect; or
 - (iv) The part in question has been modified or altered after delivery other than by the manufacturer or in accordance with a modification or alternation scheme approved in writing by the manufacturer; or
 - (v) The product is used for purposes other than conventional owner/operator usage. Usage not considered conventional owner/operator includes, but is not limited to, operation conditions that consist of rocks or other obstructions.
- (2) For the purpose of this Warranty, no part of the product or equipment will be regarded as breaching the limited warranty merely because, subsequent to its delivery, some modification or alteration becomes necessary for product improvements or in order to meet a change in the requirements of any applicable regulation.
- (3) TO THE EXTENT ALLOWED BY APPLICABLE LAW, BUYER WAIVES AS TO KRAUSE ALL OTHER WARRANTIES, WHETHER OF MERCHANTABILITY, FITNESS OR OTHERWISE, THERE ARE NO WARRANTIES WHICH EXTEND BEYOND THE DESCRIPTION ON THE FACT HEREOF.
- (4) TO THE EXTENT ALLOWED BY APPLICABLE LAW, THE OBLIGATIONS OF KRAUSE SET FORTH HEREIN SHALL BE THE EXCLUSIVE REMEDIES FOR ANY BREACH OF WARRANTY HEREUNDER, AND, TO THE SAME EXTENT, KRAUSE SHALL NOT BE LIABLE FOR ANY GENERAL, CONSEQUENTIAL OR INCIDENTAL DAMAGES, INCLUDING, WITHOUT LIMITATION, ANY DAMAGES FOR DIMINUTION OF MARKET VALUE, LOSS OF USE OR LOSS OF PROFITS, OR ANY DAMAGES TO THE PRODUCT CLAIMED BY BUYER OR ANY OTHER PERSON OR ENTITY UPON THE THEORIES OF NEGLIGENCE OR STRICT LIABILITY IN TORT.
- (5) ANY ACTION BY BUYER FOR BREACH OF THIS WARRANTY BY EITHER KRAUSE OR SELLER MUST BE COMMENCED WITHIN (1) YEAR AFTER THE CAUSE OF ACTION ACCRUES.

Establishing Customer Warranty

Dealer's Obligation

1. It is the responsibility of the dealer to complete a **Delivery Report and Warranty Registration** form. The form should contain the model, serial number, delivery date, along with the complete dealer and customer address. This form must be signed by the dealer and customer upon physical delivery of the product to the customer. The dealer must complete the **pre-delivery check list** provided on the Delivery Report and Warranty Registration form.
2. Dealer will review the **Predelivery Check List** located in the front of the operation manual with the customer and / or operator. This should be signed by the dealer at time of delivery to the retail customer.
3. The dealer will review the **Customer Review Sheet** located at the front of the operation manual with the customer and / or operator. This should be signed by the dealer representative and the customer.
4. An authorized Krause dealer will submit **warranty claims** on behalf of the customer. All claims must be handled through the dealer. They will then be given to the Krause District Manager for inspection and approval. Warranty requests must be filed within 60 days from completion of the repair for consideration.
5. It is the dealer's responsibility to **service** the warranty on products sold through said dealership.

This warranty gives you specific rights, and you may also have other rights which vary from state to state.

Establishing Customer Warranty

Customer's Obligation

1. The customer is responsible for reading the operation manual supplied with each serial numbered unit. The manual describes the safe and correct operating procedures of the specific product. The operation manual will also instruct the user on recommended lubrication and maintenance of the product.
2. The customer will advise the dealer of the anticipated start date of the product so a dealer representative can be on hand to make necessary field adjustments.
3. The owner is also responsible for inspecting the product during and after use. If a part has failed or is in need of repair, it should be replaced. When continued use of the product would result in excessive wear of other components, the part should be replaced before operation is continued. Continued use of the product may void warranty on other parts damaged from this condition. The user must make the machine available to the dealer for a warranty repair.
4. It is the customer's responsibility to deliver his machine to an authorized Krause dealer for completion of a warranty repair. If the dealer agrees to make a service trip to the customer's residence, it is an agreement between the dealer and the customer. Krause will not allow warranty credit for the cost of travel, mileage, or hauling.
5. Warranty labor consideration will only be given during the first year of warranty. Any labor charge for the 2nd or 3rd year on the limited warranty will be at the customer's expense.

This warranty gives you specific rights, and you may also have other rights which vary from state to state.

TL 6200 SERIES LANDSMAN DEALER PREDELIVERY CHECK SHEET TO BE CHECKED BY DEALER

CUSTOMER _____ DATE _____

ADDRESS _____ COUNTY _____

DEALER _____

ADDRESS _____ COUNTY _____

MODEL NUMBER _____ SERIAL NUMBER _____

DEALER CHECK:

1. ___ Check to see that all rocker shaft bolts are tight and pins are in place.
2. ___ Check to see that hydraulic cylinders are full of oil (air bled out of cylinders). Clevis pins with hairpin clips should be in place. Models TL 6200-9, TL 6200-12, TL 6200-15 require 6 Quarts / 5.76 Liters of oil; Models TL 6200-18 and TL 6200-21 require 20 Quarts / 19 Liters of oil; Models TL 6200-24 and TL 6200-27 require 24 Quarts / 22.7 Liters of oil; Model TL 6200-31 will require 34 Quarts / 32.2 Liters of oil, and Model TL 6200-36 will require 51 Quarts / 48 Liters of oil; Models TL 6200-42 and TL 6200-45 require 55 Quarts / 52 Liters.
3. ___ Examine hydraulic hoses to see that they are protected from damage.
4. ___ Bolts attaching the walking tandem to the wheel arms should be tight. Check to see that bearings have been adjusted and greased.
5. ___ Check lug bolt holding wheels to the hub to see that they are properly torqued (6 bolt wheel 120 Ft. Lbs.; 8 bolt wheels to 145 Ft. Lbs.)
6. ___ See chart below for correct size tires and their locations. Inflate all tires to the following pressures:

MODEL	CENTER SECTION	WING SECTION
TL 6200-09	(4) 9.5L x 15, 8-Ply inflated to 44 PSI	-- N/A --
TL 6200-12	(4) 9.5L x 15, 8-Ply inflated to 44 PSI	-- N/A --
TL 6200-15	(4) 9.5L x 15, 8-Ply inflated to 44 PSI	-- N/A --
TL 6200-18	(4) 11L x 15, 8-Ply inflated to 36 PSI	(4) 9.5L x 15, 8-Ply inflated to 44 PSI
TL 6200-21	(4) 11L x 15, 8-Ply inflated to 36 PSI	(4) 9.5L x 15, 8-Ply inflated to 44 PSI
TL 6200-24	(4) 11L x 15, 8-Ply inflated to 36 PSI	(4) 11L x 15, 8-Ply inflated to 36 PSI
TL 6200-27	(4) 12.5FI, 8-Bolt inflated to 90 PSI	(4) 11L x 15, 8-Ply inflated to 36 PSI
TL 6200-31	(4) 12.5FI, 8-Bolt inflated to 90 PSI	(4) 11L x 15, 8-Ply inflated to 36 PSI
TL 6200-36	(4) 12.5FI, 8-Bolt inflated to 90 PSI	(8) 11L x 15, 8-Ply inflated to 36 PSI
TL 6200-42	(4) 12.5FI, 8-Bolt inflated to 90 PSI	(8) 11L x 15, 8-Ply inflated to 36 PSI
TL 6200-45	(4) 12.5FI, 8-Bolt inflated to 90 PSI	(8) 11L x 15, 8-Ply inflated to 36 PSI

7. ___ Check to see that bolts and pins attaching hitch frame and clevis weldment to hitch are in place and tightened.
8. ___ Jack should be operational for support of tongue when implement is not attached to a tractor.
9. ___ Road lock and wing lock are engaged and operate satisfactorily.
10. ___ Restrictors are installed in wing lift cylinder rod end ports.
11. ___ All decals are in place per page P84-P85 of this owner's manual.
12. ___ Customer review sheet is filled out and signed.
13. ___ A safety chain is provided with a strength rating equal to or greater than the gross weight of the TL 6200 with attachments.
14. ___ Review lighting requirements. Light kits are standard.
15. ___ Check to see that the Owner's Manual is in the storage tube on the implement.
16. ___ Check to see that the SMV Sign is clean and in place.

DELIVERED BY: _____

DATE: _____

TL 6200 SERIES LANDSMAN CUSTOMER REVIEW SHEET

CUSTOMER _____ DATE _____

ADDRESS _____ COUNTY _____

DEALER _____

ADDRESS _____ COUNTY _____

MODEL NUMBER _____ SERIAL NUMBER _____

1. ___ Owner's manual provided.
2. ___ Warranty card filled out and mailed.
3. ___ Review safety warnings and cautions as listed in this owner's manual.
4. ___ Review recommended maximum road speed, width, and height for implement.
5. ___ Review field operational speeds, horsepower, depth, and rock conditions.
6. ___ Demonstrate the proper use of road lock.
7. ___ Explain hydraulic cylinder stroke control for depth control of tillage tool.
8. ___ Review limitations of additional weight and transport speed when adding attachments.
9. ___ Explain the importance of maintaining the tools through lubrication, checking that bolts are kept tight, and replacement of worn or broken parts.
10. ___ Recommend that a safety chain be used with the tool.
11. ___ Check wheel lug bolts frequently until they become set.
12. ___ Explain lighting requirements for your area.

DEALER: _____ DATE _____

CUSTOMER: _____ DATE _____

Contents

Rev. 9/04

WARRANTY			
DEALER PREDELIVERY CHECK SHEET	1	WING FRAMES (TL6200 42 & 45)	P24-P25
CUSTOMER REVIEW SHEET	2	WING ROCKERS (TL6200 42 & 45)	P26-P27
TABLE OF CONTENTS	3	WALKING BEAM ASSEMBLIES	P28-P29
SPECIFICATIONS	4	HUB ASSEMBLY	P30
GENERAL INFORMATION DRAWING	5	GAUGE WHEEL ASSEMBLY	P31
OPERATING SECTION		WHEELS & TIRES	P32
PROTECT YOURSELF FROM CHEMICALS	O2	TIE RODS	P33
SAFETY DECALS / INFORMATIVE DECALS	O3-O4	DISC GANG & BEARING ARM ASSEMBLY	P34-P35
ABOUT YOUR LANDSMAN	O5	2 PIECE K-TINE SHANK ASSEMBLIES	P36-P37
PREPARING FOR OPERATION	O5	XT270 SHANK ASSEMBLY	P38-P39
PREPARING THE TRACTOR	O6	SPRING SHANK ASSEMBLY	P40-P41
HYDRAULIC SAFETY	O6	WING LIFT GROUP (TL6200 - 18 thru 31)	P42-P43
Disc Gangs	O7	INSIDE/OUTSIDE WING LIFT (TL6200-36)	P44-P45
HITCHING TO THE TRACTOR	O7	INSIDE/OUTSIDE WING LIFT (TL6200-42,45))	P46-P47
UNHITCHING LANDSTAR FROM TRACTOR	O8	DEPTH VALVE ASSEMBLY	P48
Transporting	O9	HYD. HOSE STAND & LOCK VALVE BRACKET	P49
Transport Lock Valves	O9	HYDRAULICS (MODELS TL6200 9,12,15)	P49-P51
Raising and Lowering the Wings	O9	HYDRAULICS (MODEL TL6200 18,21)	P52-P53
Transport Safety	O10	HYDRAULICS (MODELS TL6200 24)	P53-P55
Hitch Pin	O10	HYDRAULICS (MODEL TL6200 27,31)	P56-P57
FIELD ADJUSTMENTS	O11	HYDRAULICS (MODEL TL6200 36)	P58-P59
Tongue Height Adjustment	O11	HYDRAULICS (MODELS TL6200 42,45)	P60-P63
Depth of Disc Blades	O12	HYDRAULIC HOSE W/PLASTIC GRIP ASS'M.	P64
Scrapers	O13	PRINCE CYLINDER 4-1/2" x 32"	P65
Sweeps	O13	PRINCE CYLINDER 4-1/4" X 10"	P66
Working Depth	O13	PRINCE CYLINDER 4" X 10"	P67
Hydraulic Depth Control	O13	PRINCE CYLINDER 3-3/4" X 10"	P68
Flexibility	O13	PRINCE CYLINDER 4" X 24"	P69
Turning in the Field	O13	PRINCE CYLINDER 4" X 30"	P70
Hydraulic Disc Gangs	O14	PRINCE CYLINDER 4" X 32"	P71
STORAGE SUGGESTIONS	O14	PRINCE CYLINDER 5" x 32"	P72
GENERAL INFORMATION	O14	PRINCE CYLINDER 2" X 5-7/8"	P73
SERVICING	O14	CYLINDER SUPPORT ASSEMBLY	P74
General Maintenance	O14	DISC GANG HYDRAULIC HOSE & FITTINGS	P75
Lubrication	O15	PACKER HITCH ASSEMBLY	P76
Wheel Bearings	O15	HYDRAULIC DISC GANG PLACEMENTS	P77-P83
Walking Beams	O15	DECALS & REFLECTORS	P84-P85
Disc Gangs	O15	LIGHT KIT	P86
Repair Parts	O16	REAR RECEPTACLE PARTS	P87
PROCEDURE TO LOCATE INTERNAL LEAKS	O17	ASSEMBLY SECTION	
Test Cases 1 through 5	O17-O19	GENERAL ASSEMBLY INSTRUCTIONS	A1
TROUBLESHOOTING SECTION	O20-O21	CENTER FRAME ASSEMBLY	A2
HYD. GANG TROUBLESHOOTING SECTION	O22	TONGUE ASSEMBLY	A2
MODEL 6336 WING FOLD SEQUENCE VALVE	O23	WALKING BEAM ASSEMBLY	A3
PARTS SECTION		SELF SUPPORTING CENTER SECTION	A5
SMV & LIGHT KIT BRACKET ASSEMBLY	P1	WING FRAMES & ROCKERS	A6
MAIN FRAME (Models TL6200 9, 12, 15)	P2	WING FOLD ASSEMBLY	A7
MAIN FRAME (Models TL6200, 18, 21, 24)	P3	GANG BEAMS - SCRAPER BAR	A8
MAIN FRAME (Models TL6200 27,31,36,42,45)	P4	UNASSEMBLED GANGS/REPAIR SEQUENCE	A9-A10
CENTER ROCKER (Models TL6200 9,12,15)	P6-P7	DISC SCRAPERS, EXTENSIONS, SHANKS	A11-A12
CENTER ROCKER (Models TL6200 18,21,24)	P8-P9	HYDRAULICS ASSEMBLY	A12
CENTER ROCKER (Models TL6200 27 thru 45)	P10-P11	DISC GANG HYDRAULICS ASSEMBLY	A14
RIGID TONGUE (Models TL6200 9 thru 24)	P12-P13	DECALS, LIGHT KIT & FINAL CHECK	A14-A15
RIGID TONGUE (Models TL6200 27 thru 45)	P14-P15	PLACEMENT DRAWINGS FOR MODELS:	
CUSHION TONGUE (Models TL6200 9 thru 31)	P16-P17	TL 6200 - 09 A18-A22	TL 6200 - 27 A48-A52
WING FRAMES (MODEL TL6200 18 thru 31)	P18-P19	TL 6200 - 12 A23-A27	TL 6200 - 31 A53-A57
WING ROCKER (MODEL TL6200 18 thru 31)	P20-P21	TL 6200 - 15 A28-A32	TL 6200 - 36 A58-A62
WING FRAMES & ROCKERS (TL6200-36)	P22-P23	TL 6200 - 18 A33-A37	TL 6200 - 42 A63-A67
		TL 6200 - 21 A38-A42	TL 6200 - 45 A68-A72
		TL 6200 - 24 A43-A47	

TL 6200 LANDSMAN SPECIFICATIONS

6/04

MODEL	CUT WIDTH FEET	CUT WIDTH METRES	NUMBER DISC	DISC SPACING	DISC BLADE SIZE	NUMBER OF SHANKS 7" SPACING	NUMBER OF SHANKS 9" SPACING
TL 6200-9	9' 0"	2.74	12	9-1/8"	20"	17	13
TL 6200-12	12' 0"	3.66	16	9-1/8"	20"	21	17
TL 6200-15	15' 0"	4.57	20	9-1/8"	20"	27	21
TL 6200-18	18' 0"	5.49	24	9-1/8"	20"	31	25
TL 6200-21	21' 0"	6.40	26	9-1/8"	20"	35	29
TL 6200-24	24' 0"	7.32	32	9-1/8"	20"	41	33
TL 6200-27	27' 0"	8.23	36	9-1/8"	20"	45	37
TL 6200-31	31' 6"	9.60	40	9-1/8"	20"	53	43
TL 6200-36	36' 0"	10.97	46	9-1/8"	20"	61	49
TL 6200-42	42' 0"	12.80	56	9-1/8"	20"	71	57
TL 6200-45	45' 0"	13.72	58	9-1/8"	20"	77	61

TL 6200 LANDSMAN TRANSPORT WIDTH & HEIGHT

MODEL	DIMENSION 'A'	DIMENSION 'B'
TL 6200-9	-----	10' 0"
TL 6200-12	-----	12' 6"
TL 6200-15	-----	16' 3"
TL 6200-18	9' 6"	12' 0"
TL 6200-21	11' 0"	12' 0"
TL 6200-24	12' 6"	12' 0"
TL 6200-27	12' 6"	14' 11"
TL 6200-31	14' 6"	14' 11"
TL 6200-36	11' 6"	14' 11"
TL 6200-42	13' 6"	15' 1"
TL 6200-45	13' 6"	15' 1"

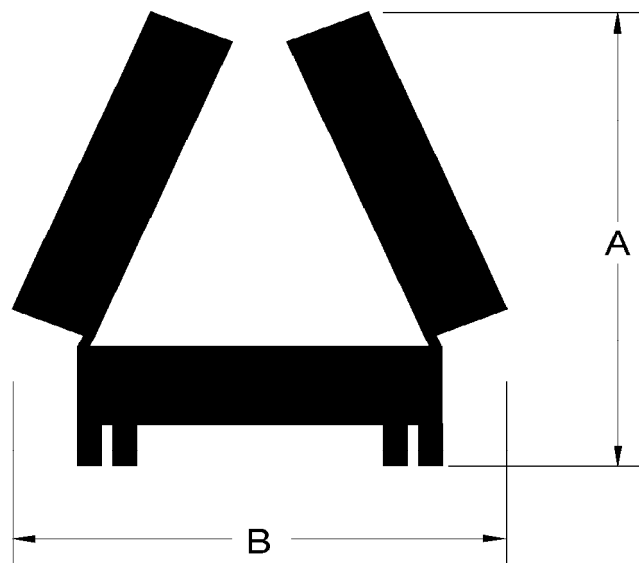

* WIDTH & HEIGHT MAY VARY WITH FINISHING ATTACHMENT

12/94

GENERAL INFORMATION



READ ALL SAFETY DECALS ON THIS UNIT AND SAFETY INFORMATION IN THIS OWNER'S MANUAL

IMPORTANT

GREASE EACH 24 HOURS OF USE

CHECK THESE POINTS PERIODICALLY FOR WEAR

TORQUE TIE ROD TO 1000 FT.LB.

CHECK POINTS OR SWEEPS FOR WEAR, TURN OR REPLACE WHEN NEEDED.

ROAD IMPLEMENT AT A REASONABLE SPEED DO NOT EXCEED 15 M.P.H.

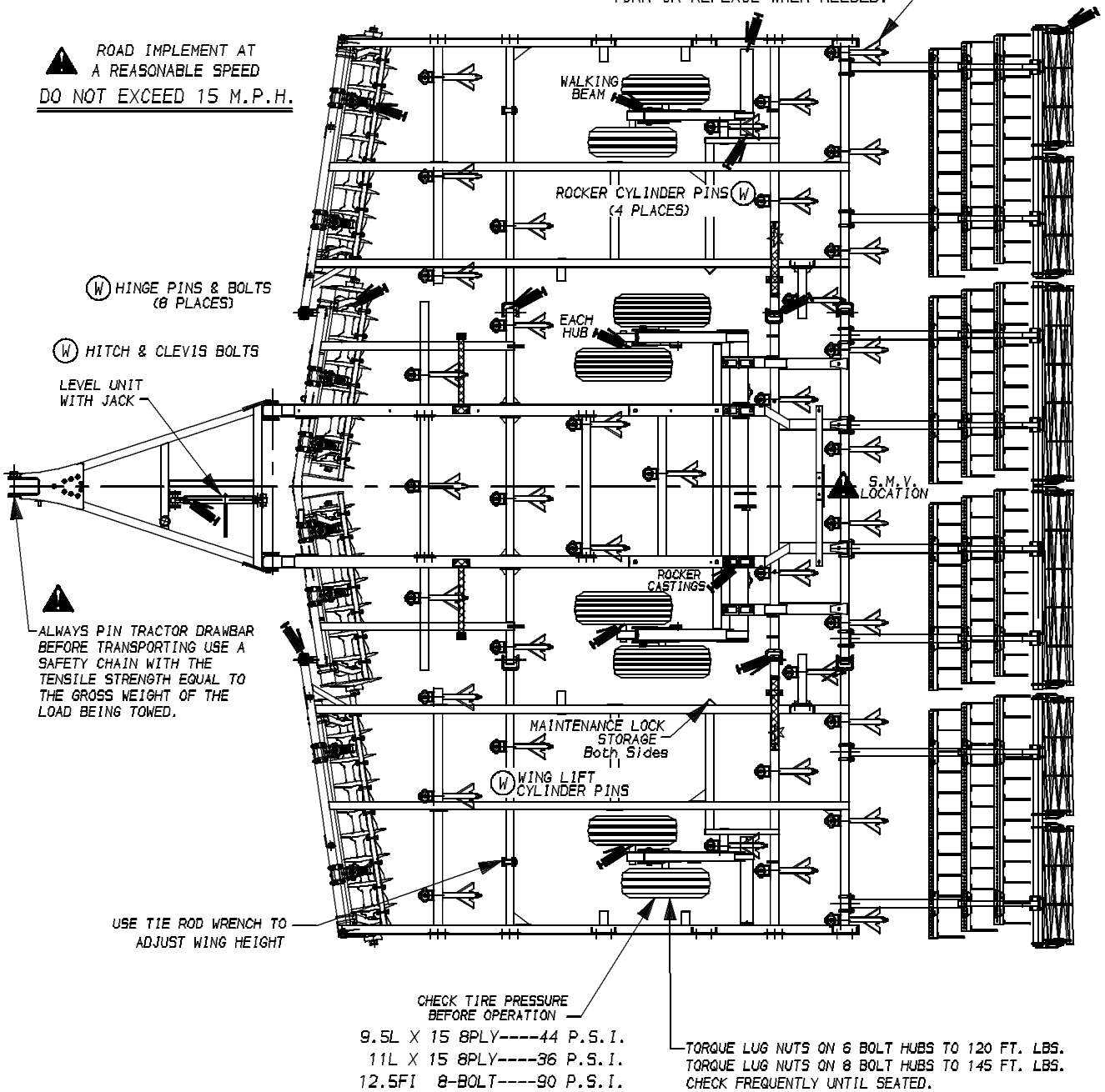

HINGE PINS & BOLTS (8 PLACES)

HITCH & CLEVIS BOLTS

LEVEL UNIT WITH JACK

ALWAYS PIN TRACTOR DRAWBAR BEFORE TRANSPORTING USE A SAFETY CHAIN WITH THE TENSILE STRENGTH EQUAL TO THE GROSS WEIGHT OF THE LOAD BEING TOWED.

USE TIE ROD WRENCH TO ADJUST WING HEIGHT

CHECK TIRE PRESSURE BEFORE OPERATION

9.5L X 15 8PLY----44 P.S.I.

11L X 15 8PLY----36 P.S.I.

12.5FI 8-BOLT----90 P.S.I.

TORQUE LUG NUTS ON 6 BOLT HUBS TO 120 FT. LBS. TORQUE LUG NUTS ON 8 BOLT HUBS TO 145 FT. LBS. CHECK FREQUENTLY UNTIL SEATED.

WARNING!

ESCAPING FLUID UNDER PRESSURE CAN PENETRATE THE SKIN CAUSING SERIOUS INJURY. AVOID THE HAZARD BY RELIEVING PRESSURE BEFORE DISCONNECTING HYDRAULIC LINES. TIGHTEN ALL CONNECTIONS BEFORE APPLYING PRESSURE.

SEARCH FOR LEAKS WITH A PIECE OF CARDBOARD. PROTECT HANDS & BODY FROM HIGH PRESSURE FLUIDS.

IF AN ACCIDENT OCCURS, SEE A DOCTOR IMMEDIATELY. ANY FLUID INJECTED INTO SKIN MUST BE SURGICALLY REMOVED WITHIN A FEW HOURS, OR GANGRENE MAY RESULT.

REV. 9/02
M6200-61

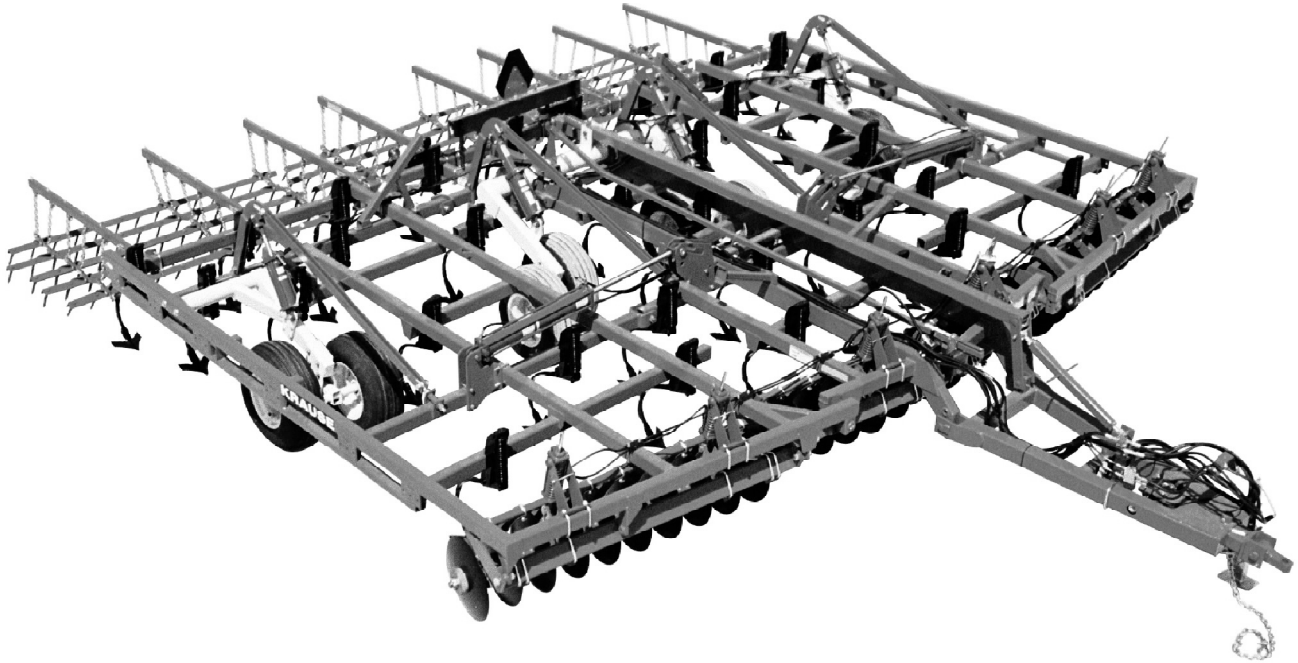

MODEL TL 6200 - 27 SHOWN

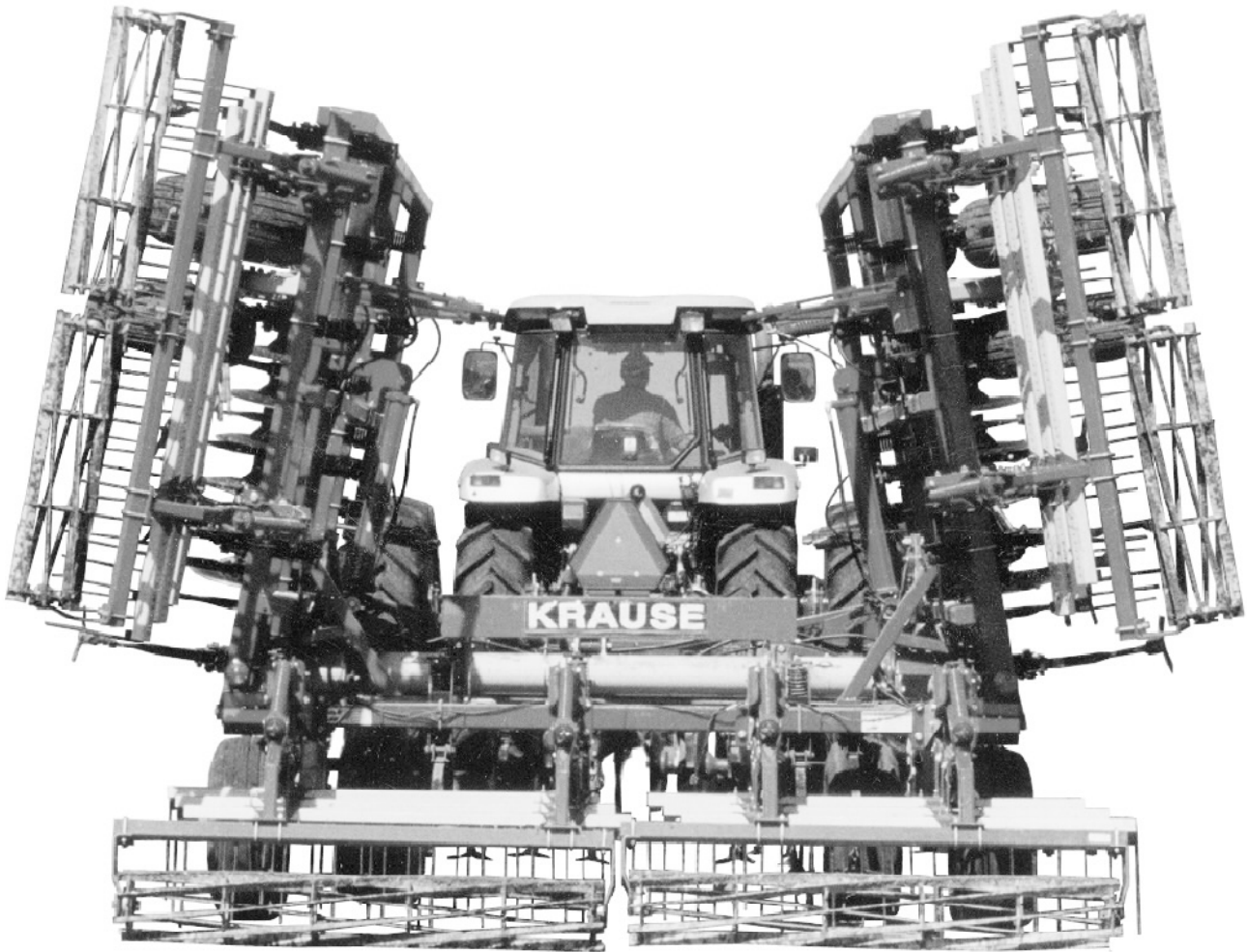

OPERATING SECTION

SAFETY ALERT SYMBOL



BE ALERT TO THE POSSIBILITY OF PERSONAL INJURY.
THIS SYMBOL IDENTIFIES IMPORTANT SAFETY MESSAGES.
CAREFULLY READ THE MESSAGE THAT FOLLOWS.

TEN MOST COMMON HAND SIGNALS USED IN THE FIELD

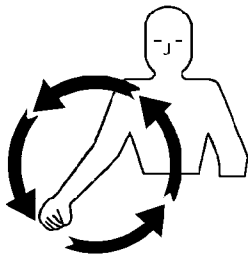

START
THE
ENGINE

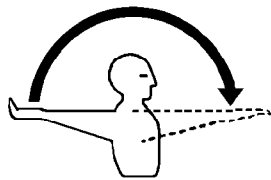

MOVE OUT
OR
TAKE OFF

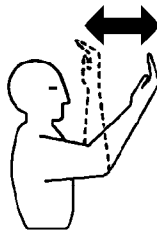

MOVE
TOWARD
ME

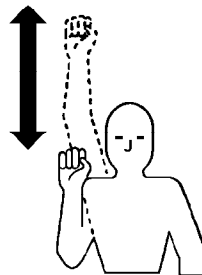

SPEED
IT UP

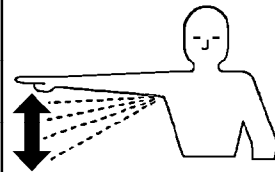

SLOW IT
DOWN



THIS FAR
TO GO



STOP



RAISE
THE
EQUIPMENT

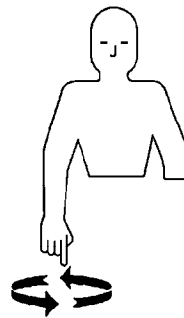

LOWER
THE
EQUIPMENT

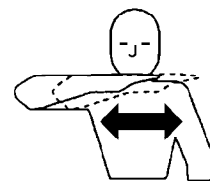

STOP
THE
ENGINE

PROTECT YOURSELF FROM CHEMICALS AND PESTICIDES

SUGGESTED PROTECTIVE GEAR:

1. **HARD HAT:** Should be washable, have a brim to collect chemicals. Replace headband if contaminated. Wash entire unit daily.
2. **GOGGLES AND FACE SHIELD:** Protect eyes, face. Goggles should fit snugly, comfortably. Shield should cover entire face.
3. **RESPIRATOR:** To prevent inhaling of chemical dust vapors. Use canisters specified for chemicals being used. Replace canisters as specified.
4. **GLOVES:** Rubber with long sleeves so cuff can be made. Unlined is best -- cloth linings are hard to wash and decontaminate.
5. **APRON / SMOCK:** Protects clothing from splashes, spills. Smock gives more body protection. Wash or replace as needed.
6. **COVERALLS:** Wear as outer layer for easy removal, if contaminated. Tight knit, closable at neck, wrists. Wash when contaminated.
7. **RUBBER BOOTS:** Protect against spills on your regular boots or shoes. Important because leather is hard to decontaminate.

NOTE: DIRTY, CONTAMINATED OR IMPROPERLY WORN PROTECTIVE CLOTHING AND EQUIPMENT MAY BE AS BAD AS USING NO SAFETY GEAR AT ALL. FOLLOW THESE LAUNDERING INSTRUCTIONS.

Change all clothing daily.

Keep clothing contaminated (worn while handling, applying) with pesticides separate from other family laundry. Keep it in a plastic bag if it is not washed immediately.

Use hot water (140° Fahrenheit) and fill machine to normal full level. Do not overload clothing.

Use recommended amount of a heavy-duty phosphate-type detergent.

Dry clothing immediately after washing, preferably in an automatic clothes dryer.

PESTICIDES AND CHEMICALS CAN ENTER YOUR BODY IN SEVERAL WAYS, SO IT IS ESSENTIAL TO WEAR A PROTECTIVE BARRIER WHILE HANDLING THEM. **THE MOST CRITICAL AREAS NEEDING PROTECTION ARE YOUR EYES, SKIN AND LUNGS.**

DON'T SMOKE OR EAT UNTIL AFTER THOROUGHLY WASHING WITH SOAP AND WATER.

USE COMMON SENSE.

SAFETY DECALS

CAUTION

READ AND UNDERSTAND YOUR OPERATOR'S MANUAL! OBSERVE ALL CAUTION, WARNING, &/OR DANGER INSTRUCTIONS AND OTHER SAFETY PRACTICES.

1. To service machines: Park on level surface and lower wings. Set parking brake and/or place in park, shut off engine and remove key. Never work under raised equipment without adequate supports. If supports are not available, completely lower unit to the ground. Block wheels if detached from tractor.
2. Do not allow riders on implement or tractor.
3. Make certain that everyone is clear before activating any controls that may cause movement of implement, hydraulics, or any components.
4. Operate with increased caution on slopes and near ditches where there is a possibility that the tractor could overturn.
5. Before transporting, engage all transport locks and safety chain. The towing vehicle must weigh more than the implement.
6. Before transporting, check tractor and implement lights, clean reflectors and make certain SMV emblem is clearly visible.
7. Maximum transport speed is 15 MPH on best road surface.
8. Store with wings down, and implement on ground or blocks.
9. Regularly inspect bolts and pins in hitch, wheel hubs, cylinders and transport locks.

FAILURE TO OBSERVE SAFETY INSTRUCTIONS AND SAFETY PRACTICES CAN CAUSE PROPERTY DAMAGE, SERIOUS BODILY INJURY, &/OR DEATH.

74-117

WARNING

To avoid injury or death due to accidental lowering of implement, move lever to LOCKED position before transporting.

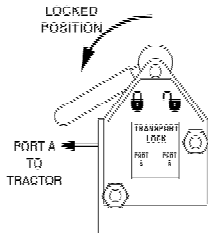

300-0308

74-383

WARNING

Escaping fluid under pressure can penetrate the skin causing serious injury or death. Relieve pressure before disconnecting hydraulic lines, tighten all connections before applying pressure, and inspect all lines before each use. See "Safety" section in operation manual for additional information.

If an accident occurs, see a doctor immediately. Any fluid injected into the skin must be surgically removed within a few hours or gangrene may result.



305-8735

74-276

WARNING

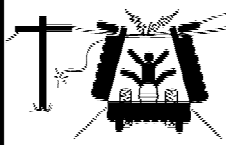

CONTACT WITH A POWER LINE OR OTHER OBSTRUCTION CAN CAUSE DAMAGE, SERIOUS BODILY INJURY OR DEATH.

Be aware of implement transport width and height.

Rear attachments will add to transport height, and transport width on some implements. See Operation Manual.

300-8734

74-121

WARNING

AIR TRAPPED INSIDE HYDRAULIC CYLINDERS CAN ALLOW IMPLEMENT OR WINGS TO FALL AND CAUSE SERIOUS BODILY INJURY OR DEATH.

Purge air from hydraulic system by following detailed steps in the Operation Manual.

305-0323

74-113

CAUTION

ADDITION OF REAR ATTACHMENTS WILL ADD 8 TO 14 INCHES TO TRANSPORT HEIGHT AND UP TO 24 INCHES IN TRANSPORT WIDTH ON SOME IMPLEMENTS. FOR YOUR SAFETY, MEASURE OVERALL WIDTH AND HEIGHT OF IMPLEMENT AFTER INSTALLING REAR ATTACHMENTS.

74-145

WARNING



FAILURE OF HYDRAULIC COMPONENTS OR ACCIDENTAL OPERATION OF HYDRAULIC CONTROLS CAN ALLOW IMPLEMENT OR WINGS TO FALL AND CAUSE SERIOUS BODILY INJURY OR DEATH!

1. Install all maintenance locks when working on or under implement. See operation manual.
2. Keep everyone clear when raising or lowering implement. Check for adequate overhead and side to side clearance before raising or lowering wings. Make certain all hydraulic systems are full of oil and free of air before raising or lowering wings or implement. Check operation manual for detailed instructions.

305-8731

74-103

WARNING

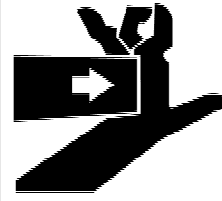

PINCH POINT

STAY CLEAR OF THIS AREA!

SERIOUS PERSONAL INJURY MAY OCCUR.

308-8887

74-128

See page P84-P85 in this manual for proper location on implement.

INFORMATIVE DECALS

KRAUSE

KRAUSE



TL 6200

See page P84-P85 in this manual for proper location on implement.

OPERATING INSTRUCTIONS



Do not allow anyone to operate this implement who has not been trained in its safe operation. Read all safety decals on the implement, and review the safety first suggestions on the back cover of this manual to refresh your memory. Watch for the safety symbol and read the information. This is for your own protection. If you do not understand any safety decal or instructions in this manual, contact your dealer for assistance.

ABOUT YOUR LANDSMAN

This Landsman Tillage tool has been designed for one-trip secondary tillage. Hinged wing sections, spring-loading of the disc gangs, shanks and attachments make it flexible enough to follow the contour of most field conditions. Wings will float down 7° and up 20°. It is designed to be used for seed bed preparation and chemical incorporation, with a maximum working depth of 6 inches. The Landsman works best at field speeds of 5 to 7-1/2 M.P.H., however, rocky conditions may require a slower field speed. Horsepower requirements, will generally be 6 to 8 drawbar horsepower per foot of cut. Krause offers five different attachments for finish tillage: three rows of tines followed by reels, three rows of tines, four rows of tines, 5 rows of spikes or 3 rows of spikes followed by reels. Caution should be used in adding any other rear attachment that will add weight to the unit.



Caution: Adding of excess additional weight could cause frame or axle failures resulting in loss of control during transport.

PREPARING THE LANDSMAN FOR OPERATION

1. The wings should be down and implement lowered to the ground. All hydraulic cylinders should be pinned and full of oil.



Caution: Lower the implement to the ground before making the following inspections. With the implement lowered, enter the framework by stepping over, do not crawl under the framework. If the implement is not lowered, any hydraulic failure could cause the implement to drop suddenly, causing personal injury.

2. The maintenance lock stops pinned to the storage brackets.
3. Check for loose bolts and tighten if needed. Check again for loose bolts after the first half day of operation.
4. Check disc gangs for tight tie rod nuts and clinched cotter pins.
5. Check the shank locations, and attachment locations with the placement diagram to be sure unit has been set-up properly.
6. Make sure that all grease zerk locations have been sufficiently greased. Grease zerks will be found on the rocker shaft bearings, walking beams, wheel hubs and hinges.
7. Check tire pressure. Inflate all tires:
9.5L x 15, 8-Ply to 44 P.S.I.
11L x 15, 8-Ply to 36 P.S.I.
12.5 FI, 8-Bolt, to 90 P.S.I.



Caution: Frequently check to see that the wheel lug bolts are properly torqued (6 bolt wheel 120 Ft. Lbs.; 8 bolt wheels to 145 Ft. Lbs) particularly during the initial transport and operation of the tillage tool. The bolts may work loose, resulting in the loss of a wheel and subsequent loss of control of the tractor and / or implement.

8. Check and adjust tightness of wheel bearings and walking beams before operation, after the first week, and periodically thereafter. (See service section on page O15)

PREPARING THE TRACTOR

Read your tractor owner's manual. It will describe safe methods of operation. Make sure your tractor has proper added ballast, and that its hydraulic system is full of oil and working properly. Check tractor brakes and warning lights, make sure that they are in working order.

HYDRAULIC SAFETY (PLEASE READ CAREFULLY)

If the implement hydraulic system has never been used, stored over a period of time or disassembled for any reason, unpin the rod ends of the cylinders and support the cylinders so the rod ends will clear frame members when fully extended. Back the tractor to the front of the implement and connect the hydraulic hoses. Check the tractor hydraulic reservoir and make sure it is full of the manufacturer's recommended oil. If you are sure the implement hydraulic hose connections are tight, begin filling the system by extending and retracting the cylinders. Hold the control lever open and pause at the end of each stroke to bleed the air from the system. Continue the cycles until the cylinders respond with immediate solid actuation. When you are sure the systems are free of air, pin the rod ends of the cylinders to the implement cylinder lugs.



Warning: Escaping fluid under pressure can penetrate the skin causing serious injury. Avoid the hazard by relieving pressure before disconnecting hydraulic lines. Tighten all connections before applying pressure.



Search for leaks with a piece of cardboard. Protect hands and body from high pressure fluids.

If an accident occurs, see a doctor immediately. Any fluid injected into the skin must be surgically removed within a few hours or gangrene may result.

AVOID HEATING NEAR PRESSURIZED HYDRAULIC HOSES

Flammable spray can be generated by heating near pressurized hydraulic hoses, resulting in severe burns to yourself and bystanders. Do not heat by welding, or using a torch near hoses. Hose can be accidentally cut when heat goes beyond the immediate flame area.

THE FOLLOWING WARNINGS PERTAIN TO THE MORE COMMON ABUSES OF HYDRAULIC HOSE:

1. **INSPECT** the hose assembly before each use.
2. **REPLACE** the hose assembly immediately if:
 - a) The jacket of the hose appears abnormal.
 - b) You have reason to believe it may be abnormal.
 - c) There is any fluid leakage.
 - d) The couplings are damaged.
 - e) The hose is damaged or kinked.
 - f) The reinforcement is visible through the jacket.
3. **DO NOT EXCEED** the maximum recommended working pressure of the hose.
4. **DO NOT KINK** the hose assembly.
5. **DO NOT BEND** the hose assembly beyond its minimum bend radius of 3.25 inches.
6. **DO NOT EXPOSE** to temperatures in excess of 225° Fahrenheit.
7. **DO NOT USE AS A STRENGTH MEMBER** for pulling or lifting equipment.



Caution: If replacing hydraulic hose, use only hose that meets or exceeds 3,000 PSI working pressure.

IMPORTANT: REPAIR OF HYDRAULIC CYLINDERS SHOULD BE MADE BY AN AUTHORIZED KRAUSE DEALER.

Prevent damage to trail hoses by supporting them from the tractor with an elastic strap "A". Avoid having excess hose between the implement support "B" and the tractor connection "C". Either reposition the hose farther back on the implement or request a shorter hose from your dealer.

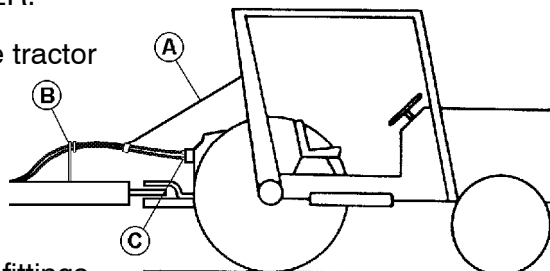

Inspect the hydraulic system for tell-tale leaks and loose fittings.

Tighten if needed. When assembling your hydraulic system, if JIC and O-Ring fittings and hoses are to be used, the use of a tape or liquid sealer is not necessary. **MAKE SURE** a restrictor (identified with a tag) is installed in the rod end port of the wing lift cylinder.

 **Caution:** Air in hydraulic system will allow implement or wings to drop suddenly.

 **Warning:** Do not operate the hydraulics until you have read “Hydraulics” in the service section of this manual.

The Landsman is equipped with two separate hydraulic systems; one to control the wheels, and the other to raise and lower the wing for transport.

Wheels -- Models 6200-18 Through 6200-45

Two master cylinders are mounted in the center on the main rocker shaft and they in turn are connected to a slave cylinder on each wing. Each cylinder in this system is a rephasing cylinder. This means there is an internal bypass in each cylinder that will let oil circulate when the cylinder is extended to its maximum stroke. All lift cylinders should work together. If cylinders are out of phase, hold the tractor valve open to extend the cylinder rod. Hold valve open until all cylinders reach their maximum stroke, then continue to hold valve open for an additional 20 to 30 seconds.

Wings

The wing lift cylinders are plumbed together. In some conditions, one wing may lift before the other, this is normal. The wings will fold and unfold slowly, because of the restrictor in the rod end of each wing cylinder. Make sure these restrictors are installed in the rod end port of the wing lift cylinders. See pages P52-P63. If not previously filled, your hydraulic system will require approximately: 6 Quarts / 5.76 Liters for Models TL 6200 9, 12 and 15; 20 Quarts / 19 Liters for Models TL 6200 18 and 21. 24 Quarts / 22.7 Liters for Models TL 6200 24 and 27. Model TL 6200 31 will require approximately 34 Quarts / 32.2 Liters of oil. Model TL 6200 36 will require approximately 51 Quarts / 48 Liters of oil. Models TL 6200 42 and 45 will require approximately 55 Quarts / 52 Liters of oil.

Use oil recommended by your tractor manufacturer. Read the service section “HYDRAULIC SAFETY” on page O6 before filling the system. See “Hydraulic Cylinders Service Manual” for additional information.

Disc Gangs

The optional hydraulic cylinders in this system are all rephasing and each is the same size and stroke. If the cylinders are not moving in unison, or one cylinder is lagging behind the system is “out-of-phase”. To rephase the cylinders simply raise the disc gangs completely and hold the tractor lever open for 30-45 seconds. This will allow oil to bypass through the rephasing grooves in each cylinder and bring all cylinders back into phase. All cylinders should now operate in unison. Repeat the raise-hold cycle anytime that the cylinders are “out-of-phase”.

HITCHING AND UNHITCHING

 **Caution:** Do not allow any person to stand between the tractor and the implement while backing into position. Sudden loss of control could cause serious injury or death to a person caught between the tractor and implement. Tell your helper to wait until you signal that the tractor is in park or neutral and the hand brake is set and engine is shut off.

Note: Hydraulic hose grips are color coded as shown below.

Black / Black Lower Unit	Red / Black Raise Unit
Yellow / Yellow Lower Wings	Red / Yellow Raise Wings
Gray / Gray Lower Disc Gangs	Red / Gray Raise Disc Gangs

1. The implement must be in a raised position and hydraulic road lock actuated before hitching to tractor.
2. Unpin the tractor drawbar so it can be moved from side-to-side.
3. Adjust tongue jack to match height of tractor drawbar.
4. Back the tractor to the implement.
5. Attach clevis to tongue hitch 1 to tractor drawbar 2 with a clevis pin 3 that fits the tractor drawbar and the clevis. Make sure the pin is locked or bolted in place 4 to prevent loss.
6. Connect the hydraulic hose to the tractor.
7. Place tongue jack in storage position.

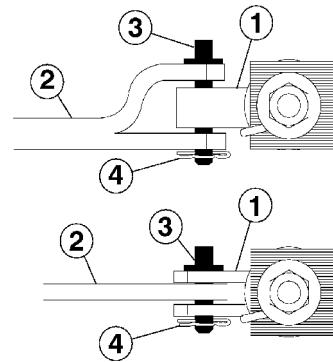

IMPORTANT: REPIN TRACTOR DRAWBAR FOR TRANSPORT. DO NOT PIN TRACTOR DRAWBAR FOR FIELD WORK.

cart.11.1

IMPORTANT: BEFORE MOVING THE IMPLEMENT BE SURE THAT THE LOWER ARMS OF THE THREE POINT HITCH HAVE BEEN RAISED TO THE TOP AND SECURED TO PREVENT DAMAGE TO THE TL 6200 CLEVIS AND TONGUE WHEN MAKING TURNS.

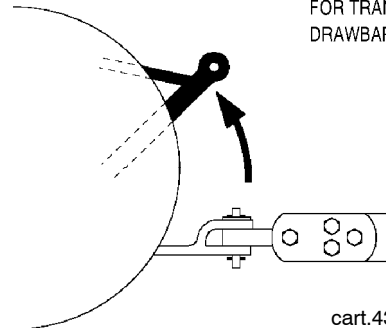

cart.43

UNHITCHING TL 6200 FROM THE TRACTOR

If the implement is not to be used for the remainder of the day, select a good parking place that will permit the lowering of the wings. The implement should be parked in the storage position. If the implement is to remain parked for storage over a long period of time, be sure to read storage suggestions.

1. To unhitch from the implement, extend the wheel cylinders and activate the hydraulic road lock.
2. Place the tractor in park or neutral and set hand brake. If tractor and implement are on an incline, block the center implement tires.
3. Open hydraulic wing lock valve.
4. Have all personnel stand clear and lower wings. Extend wing lift cylinders to their maximum.
5. With tractor in park, turn off tractor engine and relieve any pressure that might be in the implement hydraulic system by moving the tractor control levers back and forth; or place lever in "float" position.
6. Lower tongue jack and adjust until hitch pin is free.

⚠ Caution: Do not stand on or straddle a tongue when unhitching. If attachments have been added to the rear of the implement, it may affect the balance of the implement, causing the tongue to come up suddenly when unhitching.

7. Disconnect the hydraulic hoses and remove the hitch pin. The tractor may be moved away from the parked implement.

⚠ Warning: Escaping fluid under pressure can penetrate the skin causing serious injury. Avoid the hazard by relieving pressure before disconnecting hydraulic lines. Tighten all connections before applying pressure.



Search for leaks with a piece of cardboard. Protect hands and body from high pressure fluids.

If an accident occurs, see a doctor immediately. Any fluid injected into the skin must be surgically removed within a few hours or gangrene may result.

Transporting

Check specification pages and be aware of the transport height and width of your model of Landsman.

Warning: Always close both transport locks when transporting to prevent unit from falling due to hydraulic failure, or accidental activation of the operator's control. Lowering of the tool during transporting could result in loss of control of implement and/or tractor. The tractor drawbar must always be pinned for transport.

Danger: Do not exceed 15 m.p.h. in transport on best surface. Exceeding this speed can result in failure in wheel hubs or spindles and loss of control of implement and/or tractor. Do not tow this implement if its weight exceeds 1-1/2 times the weight of the towing unit. Pin tractor drawbar to prevent side sway during transport.

Transport Lock Valves

The road locks are hydraulic valves. Turning the handle to release the poppet (handle toward the tractor) will close the valve. Turning the handle to engage the poppet (handle towards the implement) will open the road lock for field use.

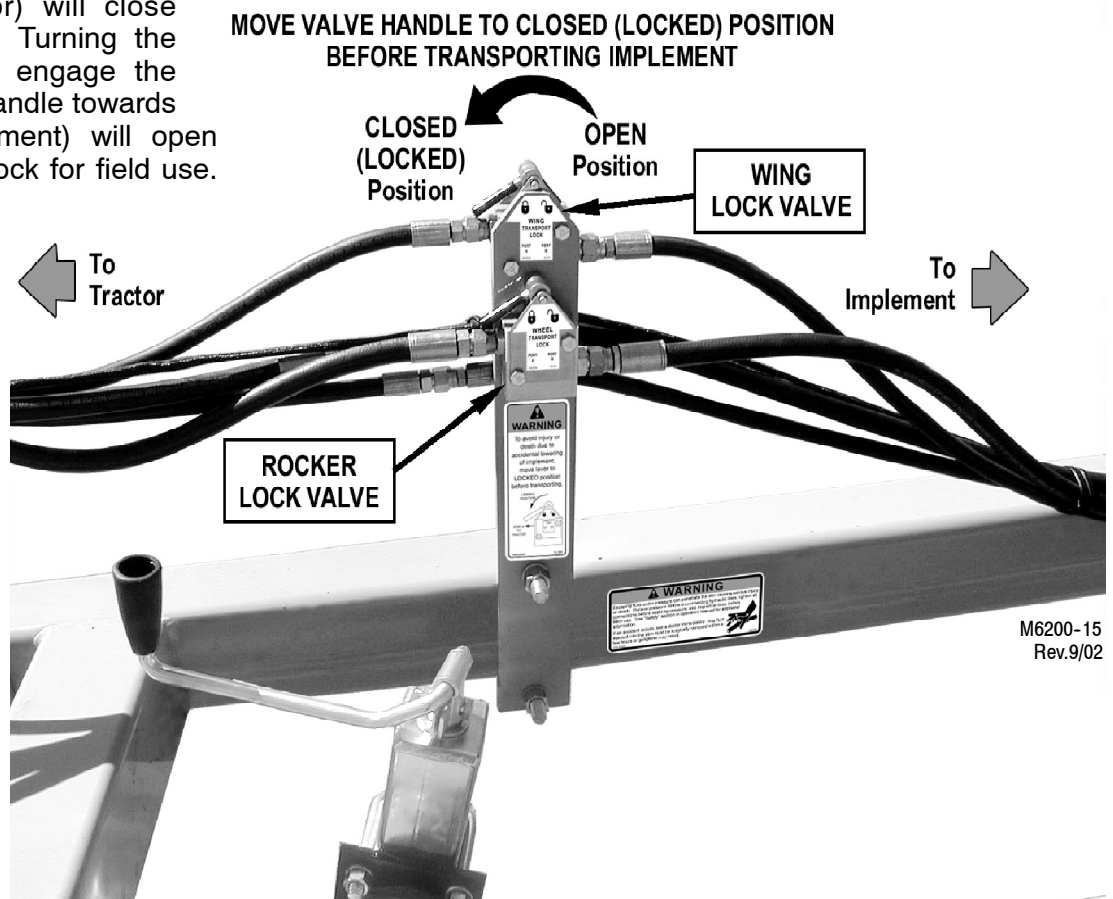

Raising The Wings

The implement should be in the raised position with the transport lock valve closed. If the system is full of oil, you are ready to also raise the wings. The wings will be secured in the raised position with the transport lock valve.

Warning: Always stand clear of wings when they are in raised position. A hydraulic failure or activation of hydraulic controls by someone could result in serious injury to anyone under the wings.

Lowering The Wings

Open the wing lock valve to unlock both wings then lower the wings with all persons standing at a safe distance away from the implement.

Transport Safety

Warning: Always use a safety chain with tensile strength equal to the gross weight of the unit, plus any attachments, when transporting.

NOTE: A safety chain, SMV emblem, and a light kit were furnished as standard equipment with your implement. Make sure they are in place, clean and in working order.

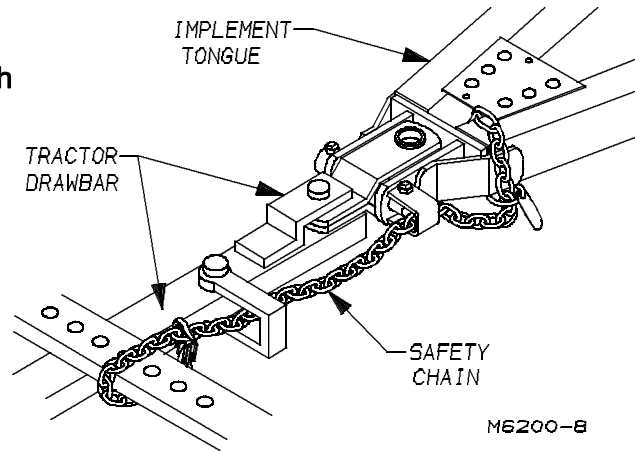

Mount the ASAE Slow Moving Vehicle (SMV) emblem point up in a plane perpendicular to the direction of travel ± 10 degrees. It shall be placed centrally at the rear of the vehicle, unobscured, and 2' to 6' (0.61 to 1.8m) above the ground, measured from the lower edge of the emblem. The SMV emblem should be wiped clean before entering the road or highways.

Comply with state and local laws pertaining to lighting and road widths. Turn on flashing lights whenever traveling on a highway except where it is prohibited by law. Transport during daylight hours only. Watch your clearance. Be aware of obstacles along the side of the roadway that might be caught by the implement when passing by. Pull over to the side of the road to permit safe clearance for oncoming traffic. Keep the red and yellow reflectors clean and visible. Replace the reflectors if they become faded or damaged. Watch for pedestrians on the side of the road that need to be warned of your presence.

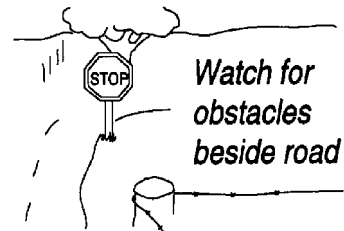

Danger: Always check conditions of transport lock valve, tires, wheels, hubs, safety chain, hitch bolts, and clevis pin before transporting the implement.

Be aware of the transport height as well as the width of your implement. Care should be taken not to snag low hanging telephone or electrical service lines.

THE REAR FINISHING ATTACHMENT MAY VARY THE OVERALL TRANSPORT WIDTH AND HEIGHT OF YOUR IMPLEMENT.

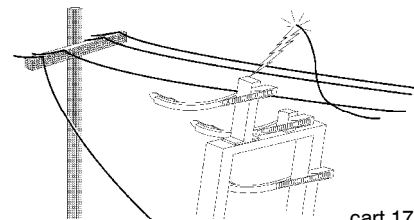

It is best to use a tractor to transport the Landsman to another location. If using another type of vehicle for towing, it should never be allowed to exceed 15 M.P.H., since the implement tires are not constructed to be operated at higher speeds. The weight of the towing vehicle should always equal or exceed the gross weight of the unit and attachments.

Always check the tire pressure before transporting and look for damaged tires. Wobble the tires from side to side. If excessive play is noted, adjust the hub spindle nut before roading to prevent damage to the hub or bearings.

Caution: It is very important to check wheel lug bolts after the first 1/2 mile of initial transport (delivery). If loose, tighten (6 bolt wheel 120 Ft. Lbs.; 8 bolt wheels to 145 Ft. Lbs). Continue to check frequently until they remain firmly seated.

Hitch Pin

Use the proper size hitch pin with a means for holding it in place so it cannot work itself out during transport. The hitch pin should be inspected for wear or cracks before using it to transport your implement.

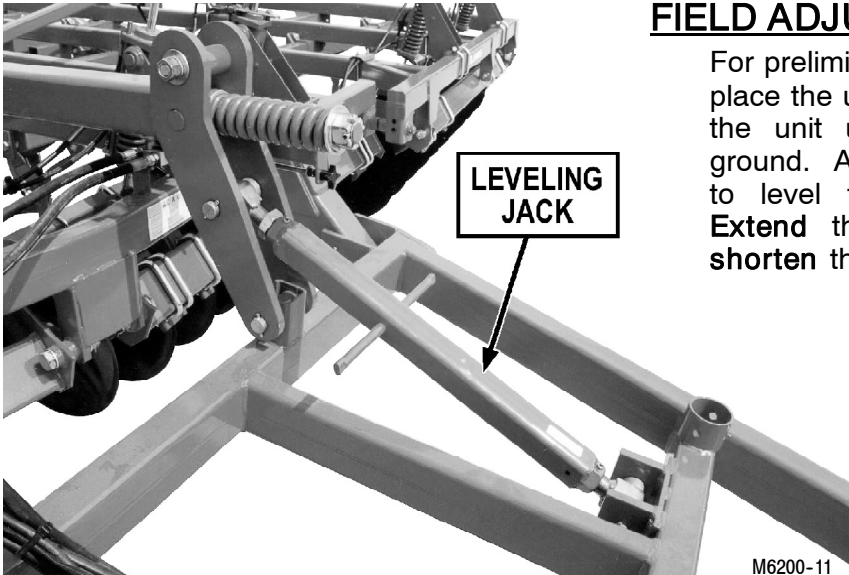

FIELD ADJUSTMENTS

For preliminary setting of the Landsman, place the unit on level ground and lower the unit until the sweeps touch the ground. Adjust the tongue leveling jack to level the unit from front-to-rear. **Extend** the jack to **raise** the front, **shorten** the jack to **lower** the front.

M6200-11

Tongue Height Adjustment

Tractors with a higher than normal drawbar, may lift the front of the Landsman during field operation. This will limit disc gang penetration and cause the unit to be unlevel in the field. This is likely to occur with tractors having a drawbar height over 18". To correct the problem, raise the tongue to the upper hole position.

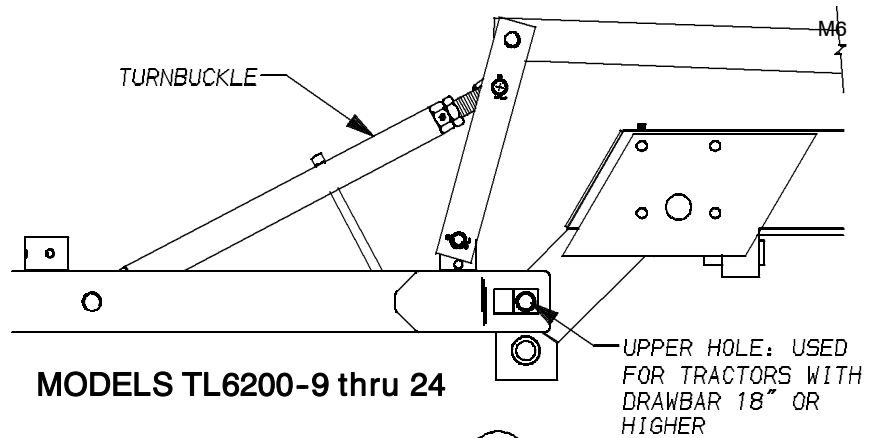

If the front of the Landsman is too high in transport, the leveling link can be moved to the lower hole to lessen tongue movement.

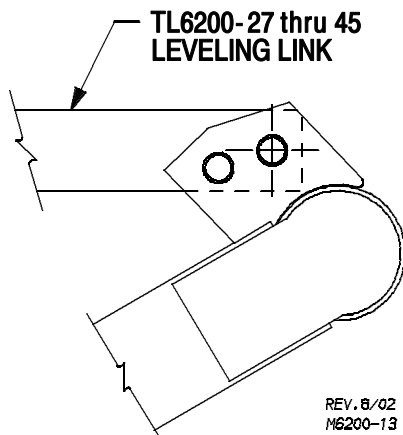
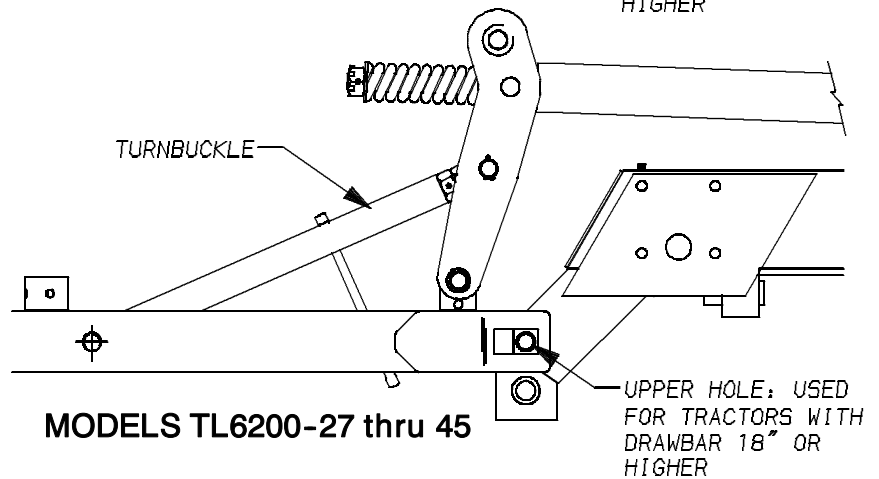

REV. 6/02
M6200-13

When making this adjustment on Models TL 6200 36, 42 and 45; also move the leveling link to the 2nd hole as shown in the illustration shown at left.

REV. 9/02
M6200-4

Disc Gang Adjustment

Adjust the SPRING SUPPORT SCREWS using the tie rod wrench until the blades touch the ground. If the gang has (TWO) Spring Supports, alternate turning each screw. Turn screw **counter-clockwise** to **lower** the gang, **clockwise** to **raise** the gang. See photo to the right.

Warning: Lower implement to the ground before entering framework to make adjustments.

Side-to-Side Leveling

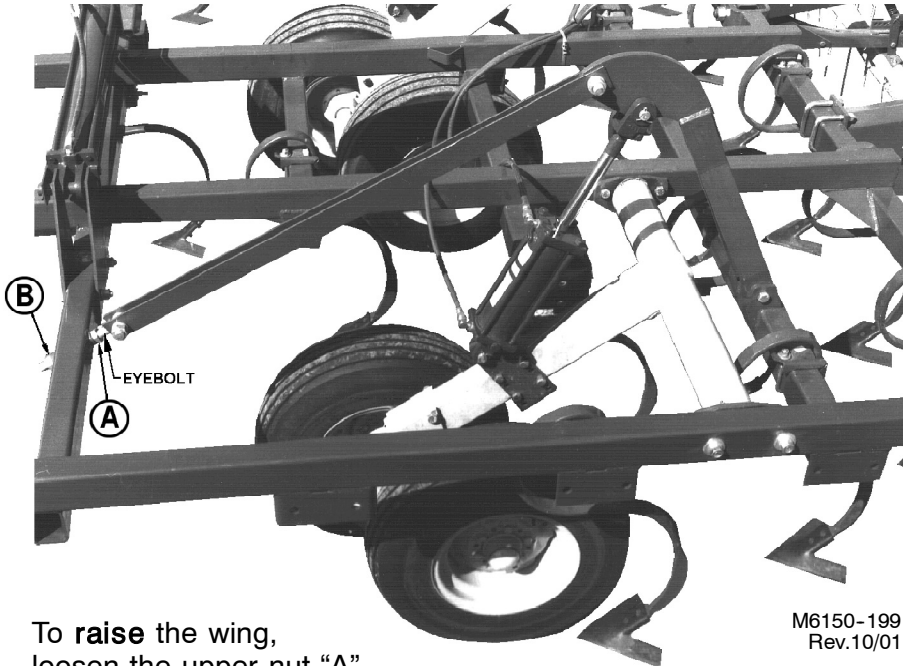

To **raise** the wing, loosen the upper nut "A", then turn the lower nut "B" to retract the eyebolt into the bracket. If the nut "B" is difficult to turn, use the fold cylinders to raise the wings slightly.

After completing this adjustment re-tighten Nut A against the bracket.

The tie rod wrench can be used to make this adjustment. The wings may require readjustment when in the field at the desired depth. See photograph above.

Depth Of Disc Blades

The depth of the disc blades can be changed by turning the SPRING SUPPORT SCREW counter-clockwise to increase depth and clockwise to decrease depth. The tie rod wrench can be used to make this adjustment. The disc blades should be run deep enough to cut trash and level the ridges from previous tillage operations. Adjust each gang as necessary. Larger gangs and those in the tractor tracks may require more spring pressure than other gangs. To check the depth of each gang, measure between the disc blade and the bottom of the frame.

When operating the hydraulic disc gangs in the fully raised position, you have the potential to trip the gang weldment up and into contact with the main and wing frame members. There is minimal clearance between the scraper bar and the frame members of the machine. If you contact a large obstacle in the the field (i.e. rocks) that requires the gangs to trip further damage will occur to the scraper bar.

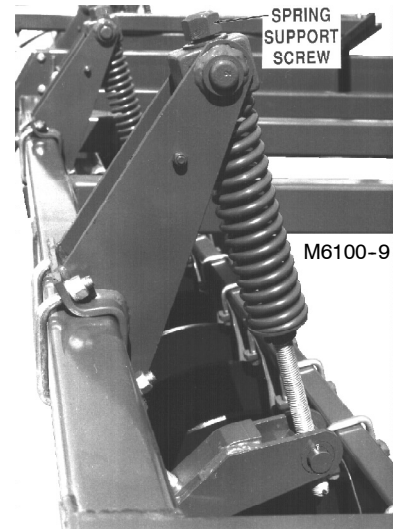

Adjust the wings to be approximately level with center frame by adjusting the eyebolt connected to cylinder bracket link.

To **lower** the wing, loosen the upper nut "A", then turn the lower nut "B" to extend the eyebolt further out of the bracket.

"X" DISTANCE	AS COMPARED TO SWEEP HEIGHT
5"	4" ABOVE
7"	2" ABOVE
9"	EVEN

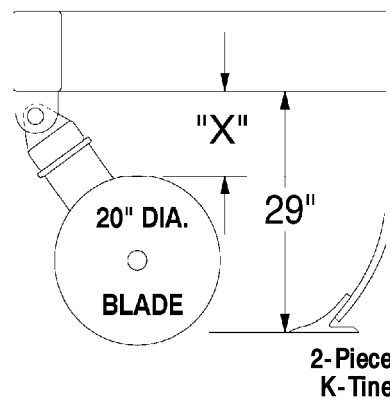

2-Piece K-Tine

M6100-12

Scrapers

Each scraper can be adjusted. For most conditions, the scraper blade should be positioned so that the scraper blade is touching on the disc blade surface.

Sweeps

10" sweeps with 47° stem angle are standard with 9" spacing.

9" Sweeps with 47° Stem angle are standard with 7" spacing.

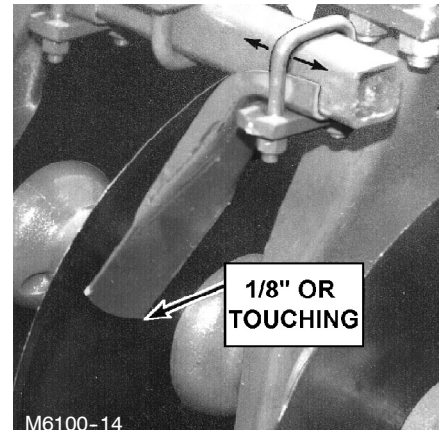

Working Depth

The working depth of your Landsman is controlled by the remote cylinder control lever of the tractor. The wheels will act as gauge wheels to regulate working depth. For uniform working depth of the soil, carry some weight on the wheels at all times. Maximum working depth is 6 inches. Incorporating chemicals may require high field speeds, but high speed may make it difficult to attain desired depth. Disc gangs, cultivator shanks, and rear attachments are spring protected; however, when working in extremely rocky conditions field speeds should be reduced.

Hydraulic Depth Control

The STOP VALVE controls the unit depth. When a depth change is required, turn the knob **clockwise to increase** the depth, turn the knob **counter-clockwise to decrease** the depth. Moving the striker assembly 3/8" will effect actual working depth by 1". If the unit depth varies during field operation, see problem solving section in this manual.

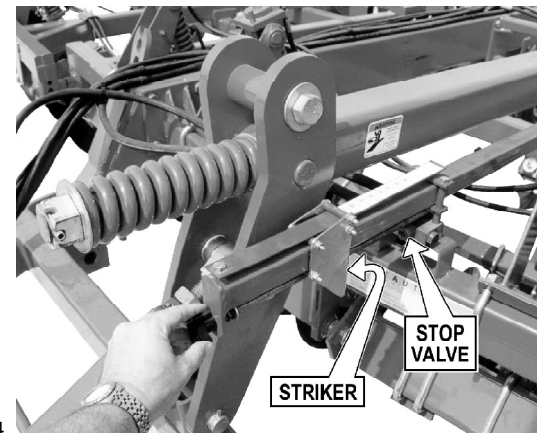

Flexibility

ALWAYS WORK WITH THE WINGS DOWN: Major damage may occur to shanks and frame members if used with the wings up. For maximum flexibility, make sure the wing hydraulic cylinders are fully extended after the wings are down.

When working terraced ground, place the wing up on the terrace, not down over the terrace as the wing is limited in its downward movement, but not as much in its upward movement.

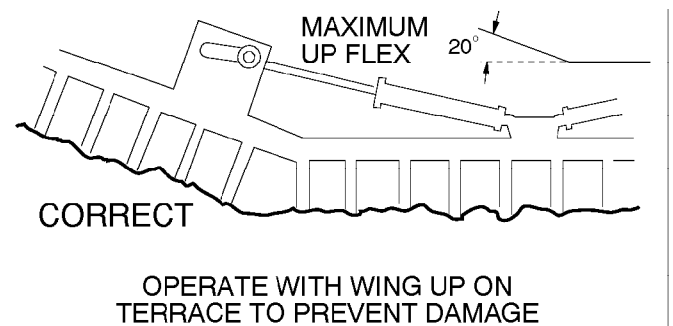
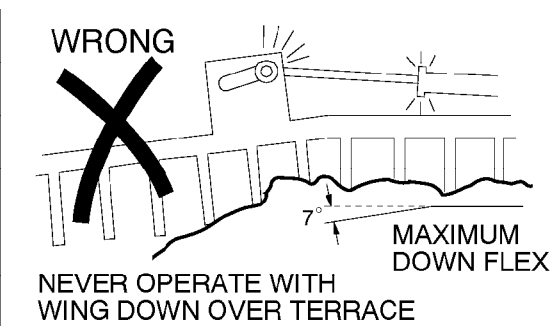

cart.7

Turning In The Field

Short turns at working depth may result in driving the outside shanks deeper into the ground, causing damage to shanks or frame members. If short turns must be executed, raise the implement out of the ground and complete the turn before engaging the tool for further tilling.

When lifting the implement completely out of the ground, hold the tractor hydraulic valve open for a second or two to resynchronize the slave cylinders.

IMPORTANT: 4-WHEEL DRIVE TRACTORS CAUSE SEVERE SIDE STRAIN ON TONGUE AND CLEVIS UNLESS THE DRAWBAR IS ALLOWED SOME FREEDOM TO SWING DURING FIELD OPERATION. DRAWBAR MUST BE PINNED FOR TRANSPORT.

Field Speed

While high field speeds of around 6-1/2 M.P.H. may be recommended for weed killing purposes in light soil and shallow depth, a slower speed is recommended for heavy soils and deep work. Slower speed will also add life to points and sweeps.

Hydraulic Disc Gangs

The hydraulic cylinders can vary the depth of the disc blades from even with the sweeps to 5" above the sweeps. The disc blades will cut residue and level ridges at the correct depth. The spring around the barrel of the cylinder allows the disc gang to flex when contacting obstructions or uneven field conditions. When adjust the depth of the gangs do not set the cylinders with more than 1-1/2" of additional spring compression. This will provide adequate preload for most field conditions. See illustration to the right.

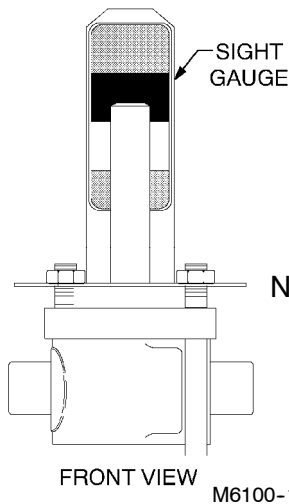

NOTE: If the disc gangs are fully raised and strike a large obstacle (i.e. rocks), the gang beam can be forced to trip into contact with the frame members causing possible damage.

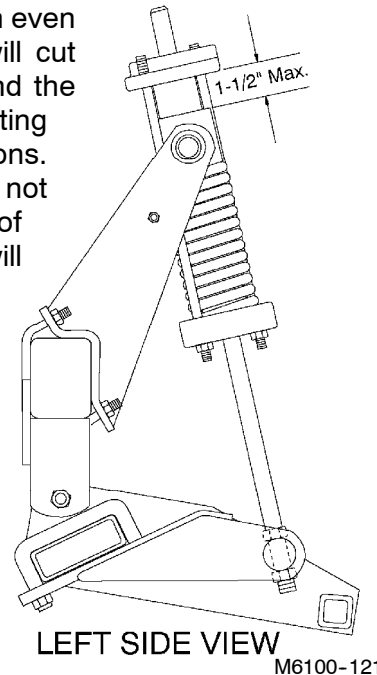

A SIGHT GAUGE is provided to indicate the relative depth of the disc gang. This can be installed on any cylinder that is convenient to view from the tractor. See illustration to the above.

STORAGE SUGGESTIONS

Make sure hydraulic transport road locks are engaged. Coat the blades and hydraulic cylinder shafts with rust preventative during extended periods of storage. Cylinder rods may be unpinned and the cylinders retracted to protect the polished surface of the cylinder rods.

For added safety lower the unit to the ground during long periods of storage. Inspect the unit for worn or damaged parts and replace as needed to avoid delays the next season.

GENERAL INFORMATION

If problems are encountered in the field, and the operator requires aid or a possible remedy for the problem, a special section has been added at the end of the Operating Section in this manual called "Suggested Remedies For Field Problems" see pages O20 - O21.

SERVICING

General Maintenance

All bolts should be checked and tightened after the first half day's operation and periodically thereafter. Torque wheel bolts (6 bolt wheel 120 Ft. Lbs.; 8 bolt wheels to 145 Ft. Lbs).

Check disc gang tie rods frequently. To tighten, attach five foot pipe over tie rod wrench handle. Tighten the nut to 1,000 Ft. Lbs. by applying approximately 200 lbs. of weight to the end of the five foot pipe.

⚠ Caution: Be sure gang is locked with a tie rod wrench on the opposite end before force is applied.

Lubrication

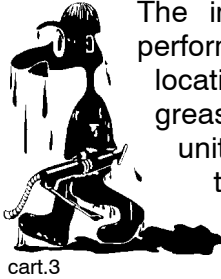

The initial lubrication of all grease fittings will assure long life and satisfactory performance from the implement. Use a multi-purpose type grease at all grease zerk locations after each 24 hours of operation. Rocker shaft bearing clamps will accept grease more efficiently if the whole unit is lowered to the ground with the weight of the unit removed from the wheels. Other points of lubrication are: wing hinges, walking tandem bearings, and wheel hubs. Disc gang bearings should be greased with a high quality multi-purpose type grease after each use and after long periods of storage. **FLUSH ROLLING REELS WITH GREASE DAILY.**

⚠ For Your Safety: When lubricating or adjusting your Landsman, watch for obstructions or protrusions. Lower implement to the ground and enter framework by stepping over. **DO NOT** walk on tires.

Wheel Bearings

Grease wheel bearings every 24 hours of use. Check for excessive end play each time that the bearings are greased. Once a year, clean and repack the wheel bearings with EP#2 Grease. Replace seals each time that the bearings are removed. Replace any worn or damaged parts. Use light oil on the seal surface and use extreme care when pushing seal over the spindle. Install outer bearings, flat washer, and slotted nut. Then back off nut from 1 to 2 slots until hub turns freely without end play. Secure nut with clinched cotter pin.

Walking Beam

Grease the walking beam every 24 hours of use. When greasing the bearings, lower the unit onto the points or sweeps and raise the walking beams off the ground. Check each walking beam for any slack in the pivot bearings. When slack is found, tighten the axle nut until slack is eliminated and tighten 5 to 10 Ft. Lbs. of preload on the bearings. **DO NOT BACK THE AXLE NUT OFF.** Check, clean, and repack the walking beam bearings each year in a procedure that is similar to that of wheel bearings.

Disc Gangs

Refer to the Assembly Section of this manual when replacing the blades, bearings or spools. Use the same procedure as described when setting up a new unit. Leave bearing bolts one turn loose until bearing arms are in place on the frame. Tighten tie rod to 1,000 Ft. Lbs. Tighten one bearing arm to the frame then tighten its bearing bolts. Make sure the other bearing arm top plate is parallel with the bottom of the frame before tightening its U-Bolts. Tighten other bearing bolts. See pages A9-A10 for further details.

Maintenance locks have been provided for use when changing out disc blades. Fully extend the cylinders and fasten the channel shaped locks onto both center rocker cylinder rods.

IMPORTANT: Rocker damage can occur if one lock is on the other lock is off.

⚠ Warning: Due to their sharpness and weight, serious injury can be inflicted by disc blades and gangs if not handled safely. Watch for unsafe conditions. Keep co-workers safety in mind. Should personal injury occur, have medical treatment administered immediately.

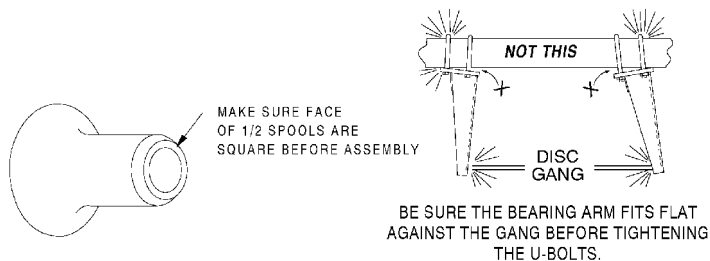

cart.25

Repair Parts

Refer to the Assembly Section of this owner's manual when repairing or replacing parts, and follow the same procedure as used when assembling a new unit. Reverse this procedure for disassembly. The Parts Section of this manual will show a breakdown of assemblies, location of parts and part numbers.

It is recommended that KRAUSE replacement parts be used. KRAUSE PARTS WERE DEVELOPED AND TESTED FOR THESE IMPLEMENTS.

⚠ Caution: Replacement tires for the LANDSMAN require the following load ratings at 10 m.p.h.; Models TL 6200 9, 12 and 15 require 2,850 lbs.; Models TL 6200 18, 21 and 24 require 2,930 lbs.; Models TL 6200 27, 31, 36, 42 and 45 require 6,160 lbs.

⚠ Danger: The wing mounted shanks and points can cause serious injury to anyone that gets too close. Never under any circumstances should anyone be allowed to work under a wing that is in the raised position.

⚠ Caution: If replacing hydraulic hose, use only hose that meets or exceeds 3,000 PSI working pressure.

IMPORTANT: REPAIR OF HYDRAULIC CYLINDERS SHOULD BE MADE BY AN AUTHORIZED KRAUSE DEALER ONLY.

⚠ Caution: Explosive separation of a tire and rim parts can cause serious injury or death. Always maintain the correct tire pressure. Do not inflate the tires above the recommended pressure. Inspect tires and wheels daily. Do not operate with low pressure, cuts or bubbles, damaged rims or missing lug bolts and nuts.

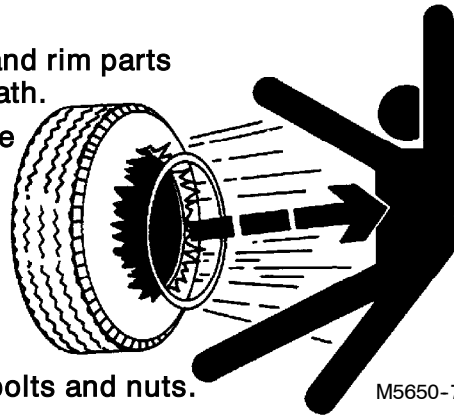

M5650-76

TEST PROCEDURE TO LOCATE INTERNAL LEAKING IN A REPHASING SYSTEM

 **For Your Safety:** Be sure to read and understand all of the hydraulic safety information on pages O6-O7 of this manual.

1. Lower the unit until the disc blades and shanks are 4" to 5" above the ground, engage the depth valve and move the tractor lever to "float" position.
2. Measure the length of the rocker cylinders and record those lengths.
3. Allow the unit to sit for a period of time until there is a measurable change in one or all of the cylinder lengths. This may require an hour or two (preferably overnight).
4. Measure the length of each cylinder again and note whether or not the cylinder extended or retracted.
5. Match your results to one of the six case studies shown on the following pages to locate the leak.

CASE 1: Field Symptom: Wing Model Landsman will not maintain set depth

Probable Causes: (A) Depth valve leak
(B) Tractor valve leak

Test Results: (See page O17) All cylinders are retracting or extending at the same rate.

Location of Leak: **IF** all cylinders are extending in the field at the same rate, the tractor valve is leaking. **IF** all the cylinders are retracting at the same rate, the leak is in the depth valve.

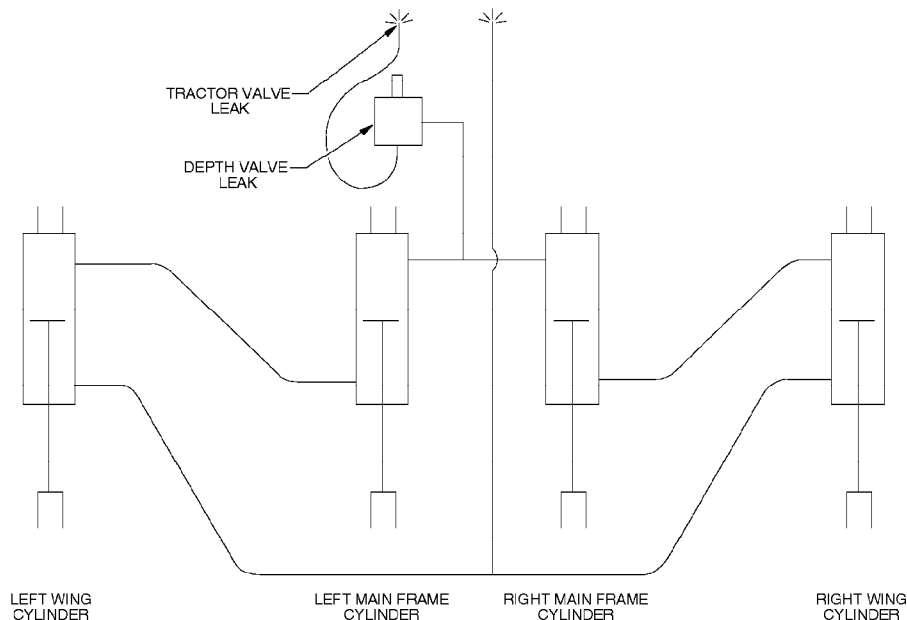

M6100-20

CASE 2: Field Symptom: Left wing lowering as the unit is pulled through the field

Probable Causes: (A) Left wing cylinder piston leaks

Test Results: (See page O17) Left cylinder retracts, all others do not change.

Location of Leak: Left wing rocker cylinder piston seal leak.

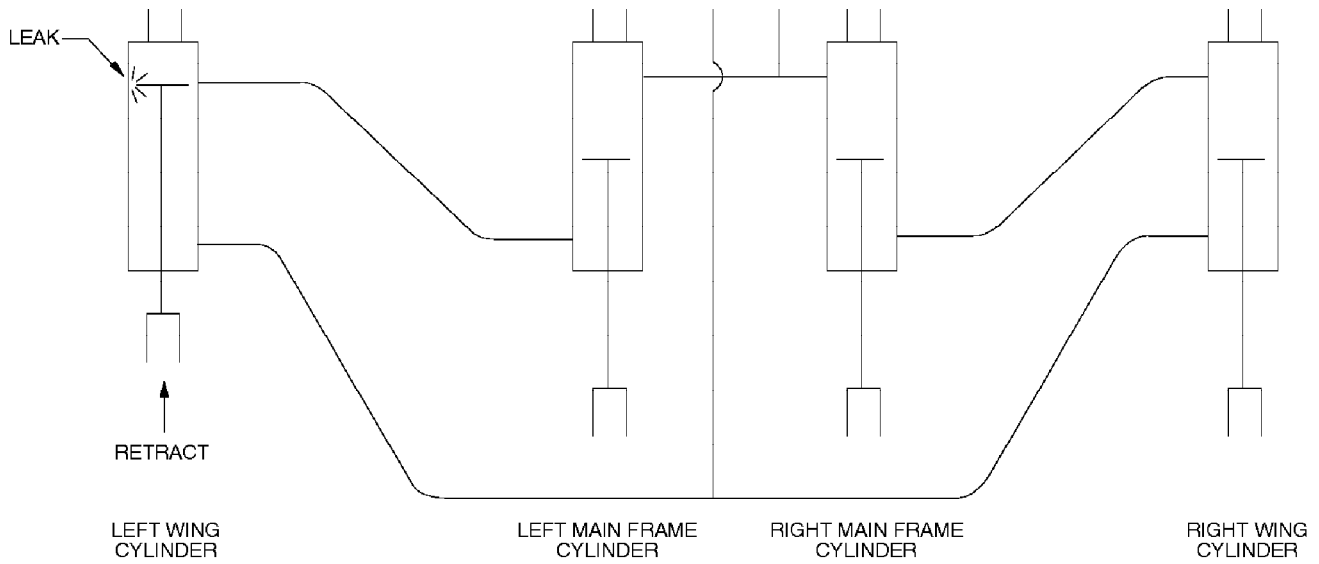

M6100-21

CASE 3: Field Symptom: Left wing raising as unit is pulled through the field

Probable Causes: (A) Left main frame piston seal leak.

Test Results: (See page O17) Left wing cylinder extends, all other cylinders retract.

Location of Leak: Left main frame rocker cylinder piston seal leak.

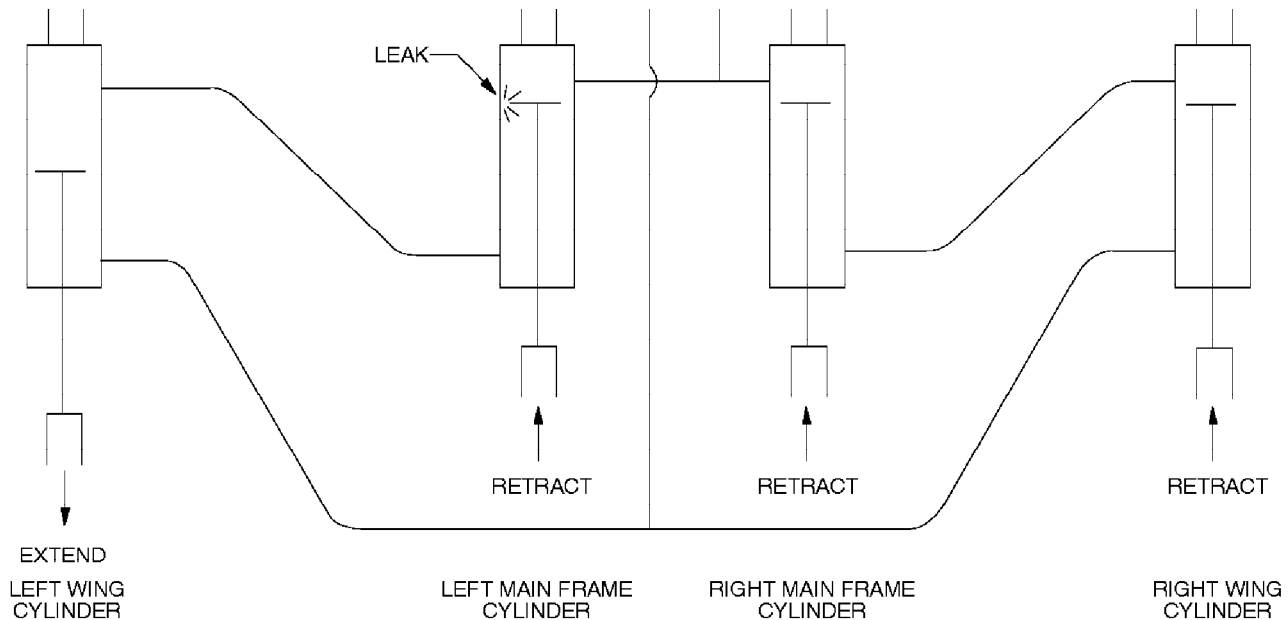

M6100-22

CASE 4: Field Symptom: Right wing lowering as the unit is pulled through the field

Probable Causes: (A) Right wing cylinder piston leaks

Test Results: (See page O17) Right wing cylinder retracts, all other cylinders do not change.

Location of Leak: Right wing rocker cylinder piston seal leak.

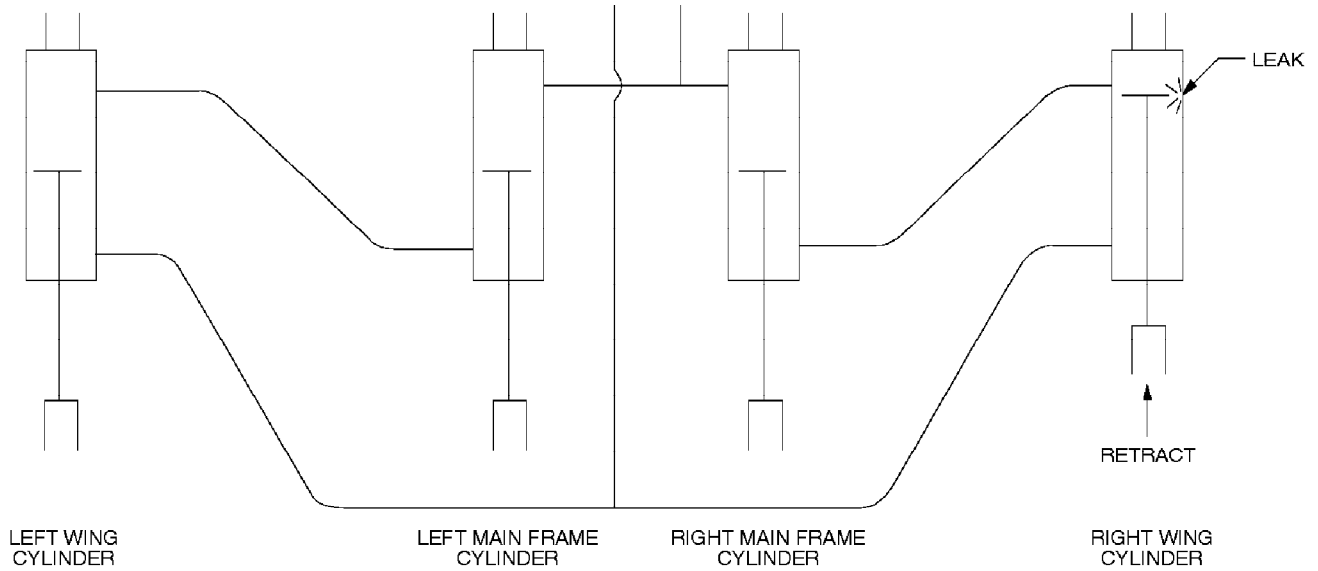

M6100-23

CASE 5: Field Symptom: Right wing raising as unit is pulled through the field

Probable Causes: (A) Right main frame piston seal leak.

Test Results: (See page O17) Right wing cylinder extends, all other cylinders retract.

Location of Leak: Right main frame rocker cylinder piston seal leak.

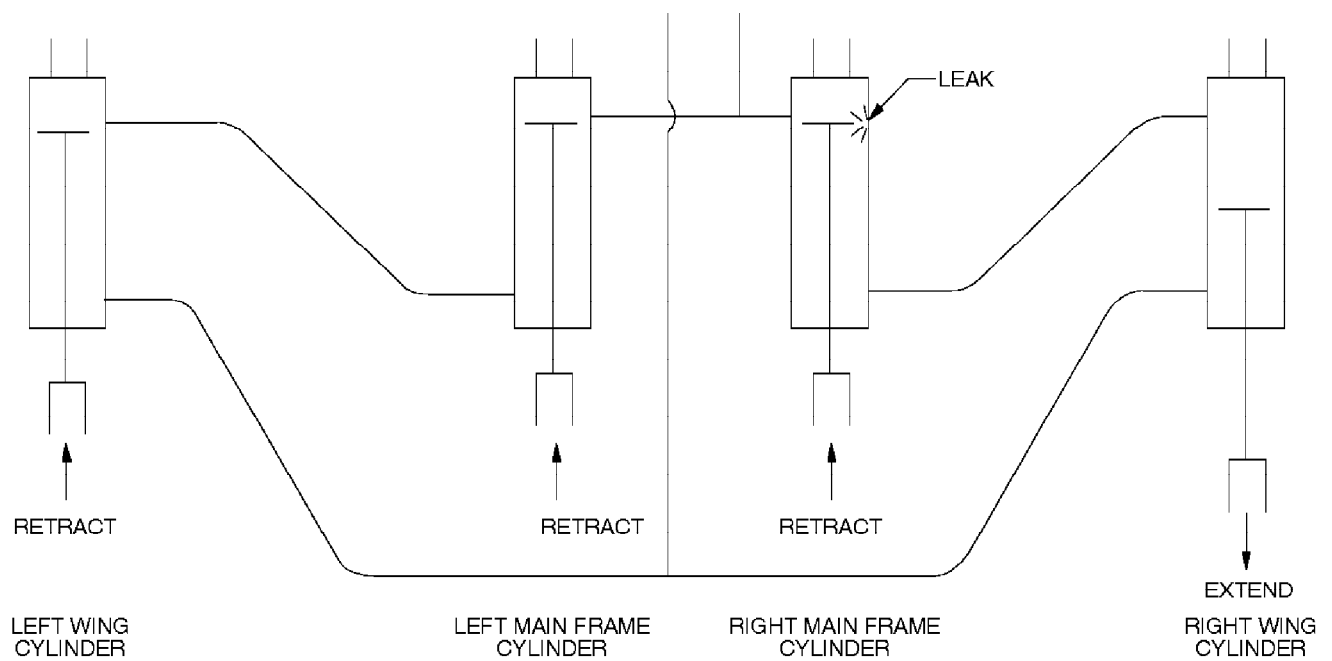

M6100-24

POSSIBLE REMEDIES FOR FIELD PROBLEMS

PROBLEM	POSSIBLE CAUSE	SUGGESTED REMEDY
Leaving center ridge	Excessive speed	Reduce speed
	Front of unit is not level	Adjust tongue
	Disc too close to center	Spread apart. More pressure on reel or tines.
	Shank missing	Replace.
Furrow on outside	Outside of wing too low	Readjust eyebolt to level wing.
	Some shanks out of place or missing	Readjust position or replace
	Wing wheels out of phase with center wheels	Rephase
Outside too shallow	Outside of wing too high	Readjust eyebolt to level wing.
	Wing will not flex down	Wing lift cylinder not completely extended
	Wing wheels out of phase with center wheels	Rephase
Not level from front-to-rear with uneven penetration	Tongue not adjust properly	Readjust tongue leveling
	Tire not same size	Replace with same size and ply tire
Center section not level from side-to-side	Uneven tire PSI	Check tire PSI
	Tire not same size	Replace with same size and ply tire
Plugging (Disc)	Wet conditions	Allow to dry if possible
	Worn or improper adjustment of scraper blade	Readjust scraper
Plugging (Shanks)	Wet conditions	Allow to dry if possible
	Straw is dragging	Work deeper
	Shanks positioned wrong	Recheck shank spacing
		Relocate shank
Plugging (Tines & Reels)	Wet conditions	Allow to dry if possible
	Reel not turning	Check bearing; rock or trash lodged in reel
Excessive ridges	Loose sweep bolts	Tighten bolts or replace if missing
	Improper shank spacing or wrong position	Check placement page; relocate shanks
	Bent or lost sweep	Replace sweep
	Frame not level	Check front-to-rear leveling and side-to-side leveling. See page O12
	Bent shank	Straighten or replace
	Sweeps with old residue will cause soil build-up and prevent necessary scouring for even soil flow	Remove trash and residue. Clean Landsman after operation. Use rust preventative before storage
	Star wheel running in shank mark	Slide star wheel assembly
Implement will not penetrate	Incorrect setting of depth stop	Readjust stop for desired depth
	Ground too hard	Wait for better conditions
	Disc blades dull	Replace or sharpen disc blades
	Sweeps have wrong angle	Use correct stem angle. See page O13
	Excessive field speed	Slow down

IMPORTANT: DO NOT REMOVE SHANKS OR WORK WITH WINGS UP.

PROBLEM	POSSIBLE CAUSE	SUGGESTED REMEDY
Disc gang does not revolve	Obstruction in disc gang	Check for rocks, mud, roots, etc.
	Scrapers adjusted too tight against blade	Readjust scrapers. See page O13
	Seized bearing	Replace
	Plugging at bearing	Try removing scraper at this location
Disc blades have excessive wobble	Tie rod nut loose	Retorque tie rod nut to 1,000 Ft. Lbs.
Wheels have excessive wobble	Loose wheel bolts	Immediately stop and torque wheel bolts. (6 bolt wheel 120 Ft. Lbs.; 8 bolt wheels to 145 Ft. Lbs)
	Loose spindle nut	Tighten nut until tight; then back off 1 slot
	Walking beam loose	Readjust bearings Replace bearings in walking beam
Inadequate transport clearance	Low tractor drawbar height	Tractor with unusually low drawbar. Adjust tongue leveling jack for clearance
Wing will not raise to field position	Plugged restrictor	Relieve hydraulic pressure. Remove restrictor from rod end and check the orifice for foreign material. Replace restrictor.
	Insufficient hydraulic pressure	Check tractor hydraulic system
Wings will not lower to field position	Plugged restrictor	Relieve hydraulic pressure. Remove restrictor from rod end and check orifice for foreign material. Replace restrictor.
	Wings are locked with pins	Remove both wing lock straps
	Hose couplers not locked into tractor disconnect socket	Check hydraulic hose connector
Implement will not lower to field position	Road locks engaged	Disengage both road locks
	Hose couplers not locked into tractor disconnect socket	Check hydraulic hose connector
	Oil not flowing through system	Plugged line of cylinder port. Depth control poppet valve not open.
	Depth stop striker in wrong position	Readjust depth stop
Implement continually settling or going deeper	Hydraulic system	Replace poppet valve seal. Check for leaks in system. Install new cylinder seal kit in faulty cylinder. See cylinder page in Parts Section in this manual.
Tractor tracks evident behind finishing attachment	Compaction of soil	Remove excess tractor weight
		Wait for drier field conditions
		Install shank extenders to fracture deeper compaction
		Add additional shanks in tractor tracks

HYDRAULIC DISC GANG PROBLEM SOLVING:

NOTE: THE NUMBER 1 CAUSE OF HYDRAULIC CYLINDER FAILURE IS CONTAMINATED OIL.

To evaluate any cylinder problems, begin by repeating the raise-hold cycle several times to insure that all air is bled from the system. Then raise the disc gangs and lower the unit until the sweeps are at field operating depth. Lower the disc gangs and compress the cylinder springs approximately 1-1/2". Allow the unit to sit for a period of time until there is a noticeable change in the amount that the springs are compressed.

CASE 1: Test Results: All cylinders are retracting or extending at the same rate
Field Symptom: Depth of all disc gangs change during field usage.
Probable Causes: Lock valve leak

CASE 2: Test Results: 1 or more cylinders settle back other cylinders hold springs compressed.
Field Symptom: 1 or more disc gangs change depth and are repeatedly out-of-phase with other disc gangs.
Probable Causes: Cylinder piston leak in cylinder(s) that settle back.

CASE 2: Test Results: Unable to operate disc gang cylinders.
Probable Causes: (a) Hoses are not coupled to tractor properly
(b) Hoses not routed correctly between cylinders
(c) Restrictor fitting in 1st cylinder plugged.

MODEL TL 6200-36, 42 & 45 WING FOLD SEQUENCE VALVE

This model is a full 5-Section Landsman, which uses a sequence valve to cause the inside wings to unfold before the outside wings unfold.

IMPORTANT: THE INSIDE WINGS SHOULD UNFOLD COMPLETELY BEFORE THE OUTER WINGS BEGIN TO UNFOLD. IF IT DOES NOT LET THE INSIDE WING COMPLETELY UNFOLD, CHECK AND / OR CORRECT AS DESCRIBED BELOW.

<u>POSSIBLE CAUSE</u>	<u>REMEDY</u>
1. 25-324 In-Line Restrictor is not plumbed in correct place.	Correct hydraulic plumbing as shown on pages P42-P43, and A12-A13.
2. Sequence Valve is not set properly	a) Fold outer wing only b) Increase sequence valve pressure until wing cannot be unfolded. c) Decrease valve pressure only enough to allow outer wings to unfold.
3. Internal leaks in valve	Replace valve.

 Warning: Always stand clear of wings when they are in the raised position. A hydraulic failure or activation of hydraulic controls by someone could result in serious injury to anyone under the wings.

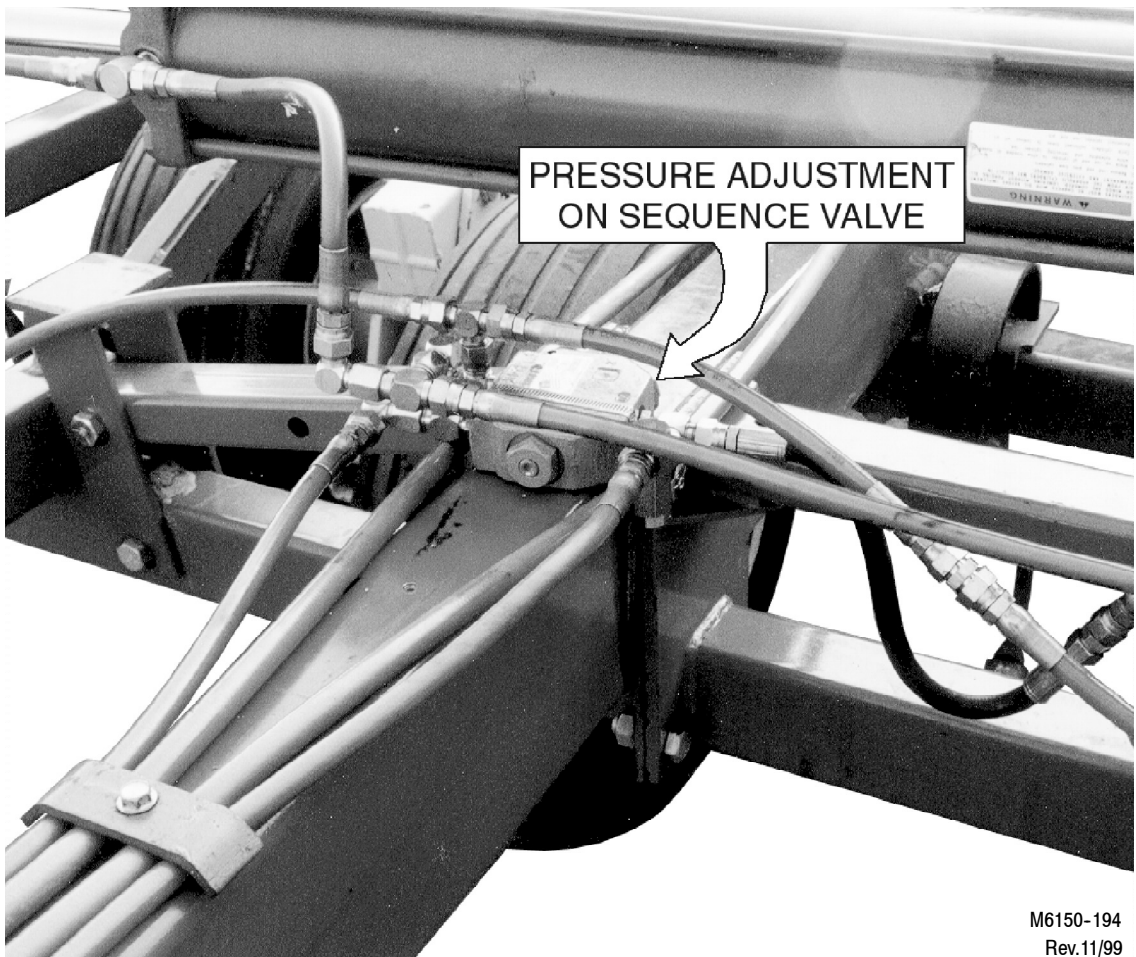

M6150-194
Rev.11/99

This page intentionally left blank.

PARTS SECTION

THE FOLLOWING ILLUSTRATED PARTS SECTION HAS BEEN COMPILED TO REFLECT PART NUMBERS REQUIRED TO ORDER PARTS, AND TO SUPPORT THE ASSEMBLY SECTION FOR DIMENSIONS AND DESCRIPTIONS OF ALL PARTS, BOLTS, PINS, ETC. THE OPERATOR CAN ALSO IDENTIFY PART NAMES TO CLARIFY PROPER OPERATIONAL STEPS.

SMV & LIGHT KIT MOUNTING BRACKET ASSEMBLY

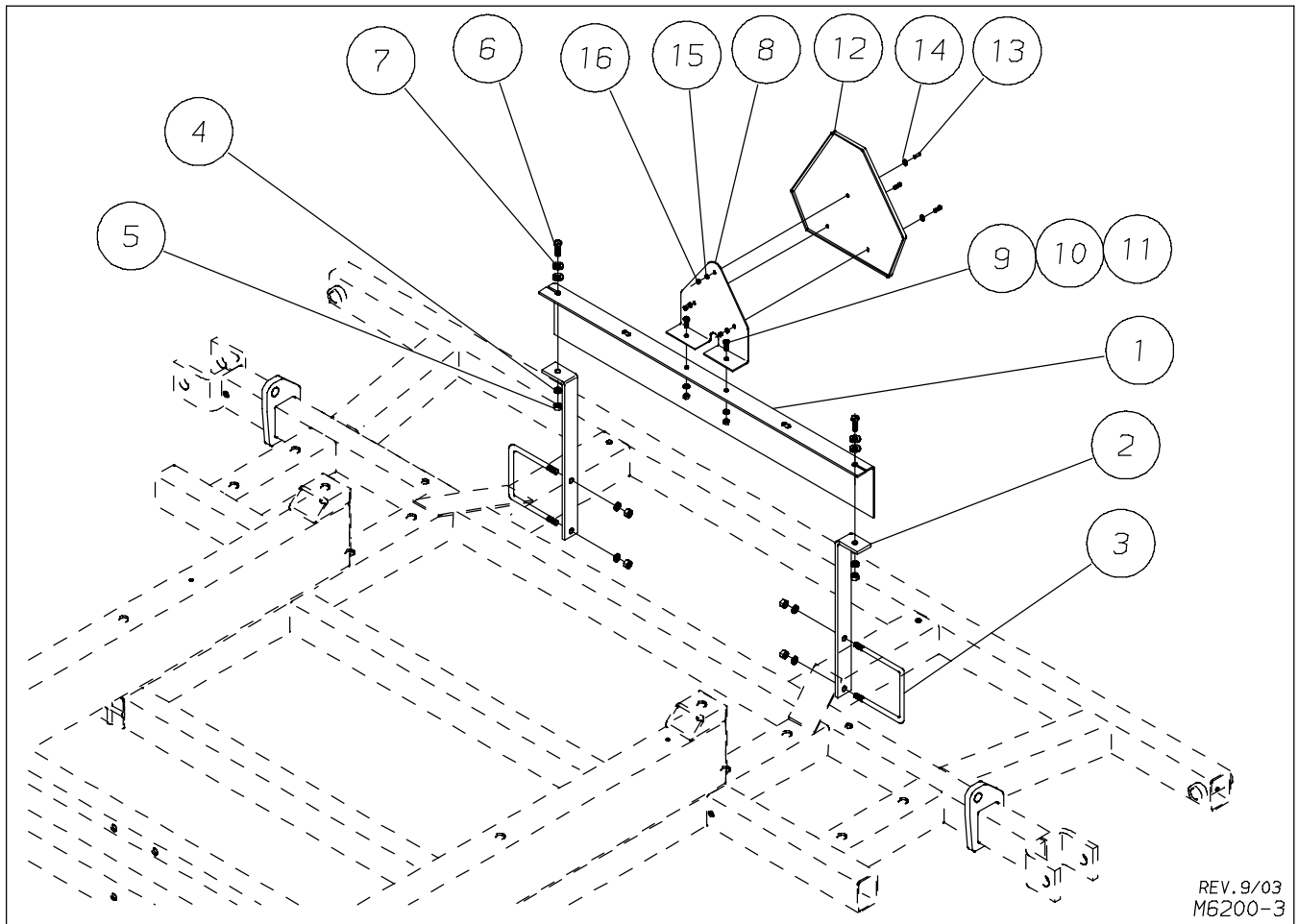

REV. 9/03
M6200-3

FOR MODELS - ALL

9/03

Item	Part Number	Part Description	Qty.
1	●▲ 5630-0-33	Decal & SMV Mount	1
	■ 4881-0-2	Decal & SMV Mount	1
2	●▲ 6345-0-7	Mounting Bracket	2
	■ 6201-0-3	Mounting Bracket	2
3	■● 61-216	U-Bolt - 1/2" DIA. x 4-1/16"W x 4-1/4"L	2
	▲ 61-152	U-Bolt - 1/2" DIA. x 4-1/16"W x 5-1/8"L	2
4	64-107	1/2" STD. Lock Washer	6
5	63-106	1/2NC Hex Nut	6
6	62-420	1/2NC x 1-1/4" GD5 Cap Screw	2
7	64-108	1/2" STD. Flat Washer	4
8	5630-0-34	SMV Bracket	1
9	62-493	3/8NC x 3/4" GD5 Cap Screw	2
10	64-103	3/8" STD. Lock Washer	2
11	63-102	3/8NC Hex Nut	2
12	74-487	SMV Sign	1
13	62-507	1/4NC x 3/4" GD5 Cap Screw	3
14	64-101	1/4" STD. Flat Washer	3
15	64-100	1/4" STD. Lock Washer	3
16	63-100	1/4NC Hex Nut	3
	■	For Models TL 6200-09 thru TL6200-15	
	●	For Models TL 6200-18 thru TL6200-24	
	▲	For Models TL 6200-27 thru TL6200-45	

MAIN FRAME ASSEMBLY

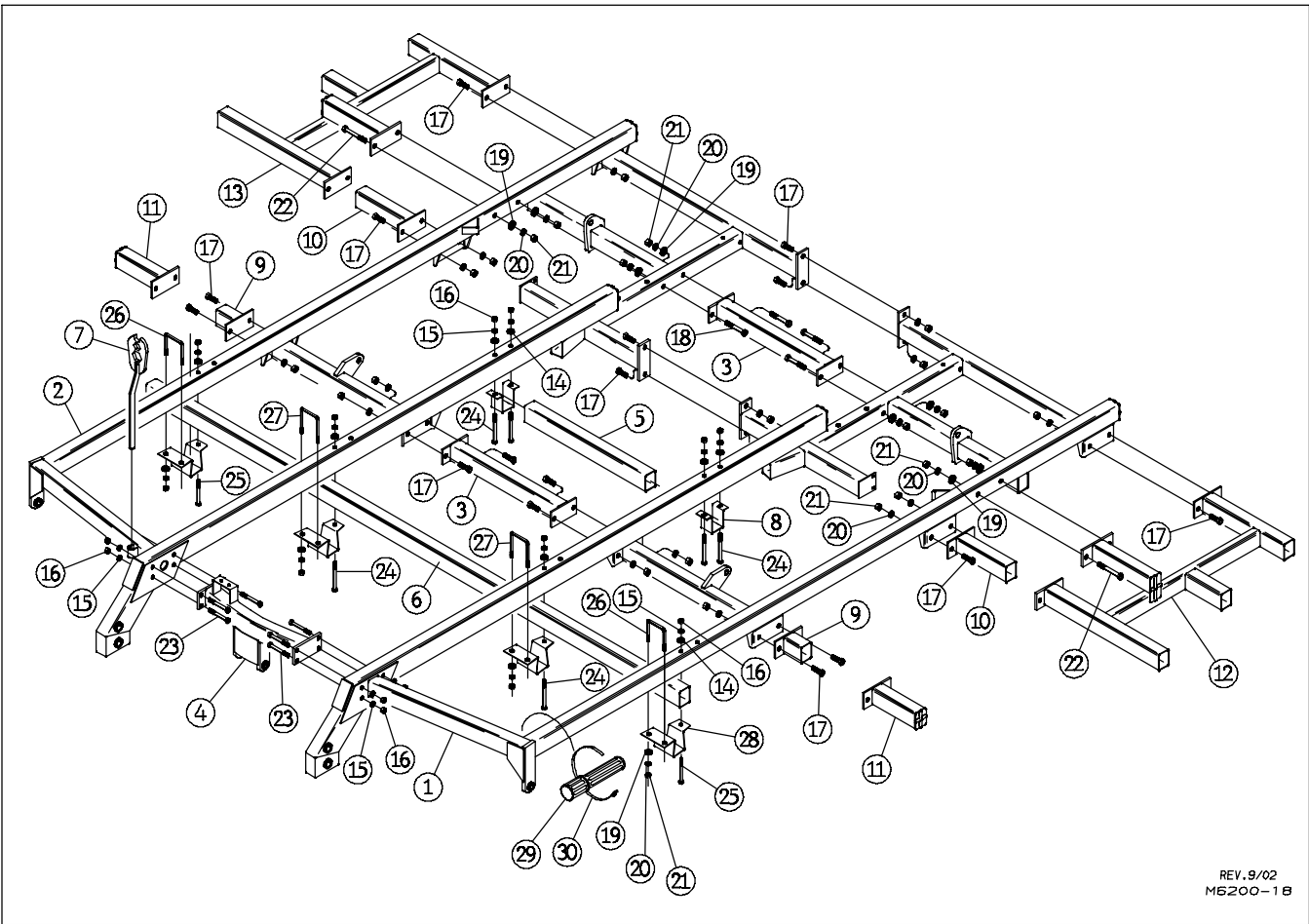

REV. 9/02
M6200-1B

FOR MODELS - TL 6200 9, 12 15

9/03

Item	Part Number	Part Description	Qty.	Item	Part Number	Part Description	Qty.
1	6200-1-0	Left Main Frame Weldment	1	18	62-203	3/4NC x 4-1/2"GD5 Cap Screw	4
2	6200-2-0	Right Main Frame Weldment	1	19	64-113	3/4" STD. Flat Washer	Spec
3	6112-35-0	Frame Connector Weldment	2	20	64-112	3/4" STD. Lock Washer	Spec
4	6112-40-0A	Front Connector Weldment	1	21	63-112	3/4NC Hex Nut	Spec
5	6112-0-1	Shank Box - 34" Long	1	22	62-207	3/4NC x 5-1/2" GD5 Cap Screw	4
6	● 4100-961-1	Beam - 110" Long	1	23	62-439	5/8NC x 5" GD5 Cap Screw	8
	★ 6155-450-1	Beam - 160" Long	1	24	62-330	5/8NC x 6-1/2"GD5 Cap Screw	6
7	6127-25-0	Tie Rod Wrench Weldment	1	25	62-566	5/8NC x 5-1/2"GD5 Cap Screw	2
8	6127-454-0	Box Clamp Weldment	2	26	61-232	3/4" DIA. U-Bolt	2
9	4122-60-0	One Shank Extension Wldmnt	2	27	61-207	3/4" DIA. U-Bolt	2
10	6200-42-0	Two Shank Extension Wldmnt	4	28	6150-454-0	Box Clamp Weldment	4
11	6200-42-0	Two Shank Extension Wldmnt	2	29	99-218	Owner's Manual Storage Tube	1
12	★ 6202-37-0	Left Four Shank Extension	1	30	25-1163	Hose Clamp	1
13	★ 6202-36-0	Right Four Shank Extension	1	● Used on Model TL6200 9 ONLY			
14	64-110	5/8" STD. Flat Washer	8	■ Used on Model TL6200 12 ONLY			
15	64-109	5/8" STD. Lock Washer	16	★ Used on Model TL6200 15 ONLY			
16	63-109	5/8NC Hex Nut	16				
17	62-421	3/4NC x 2" GD5 Cap Screw	●8/ 20■★				

MAIN FRAME ASSEMBLY

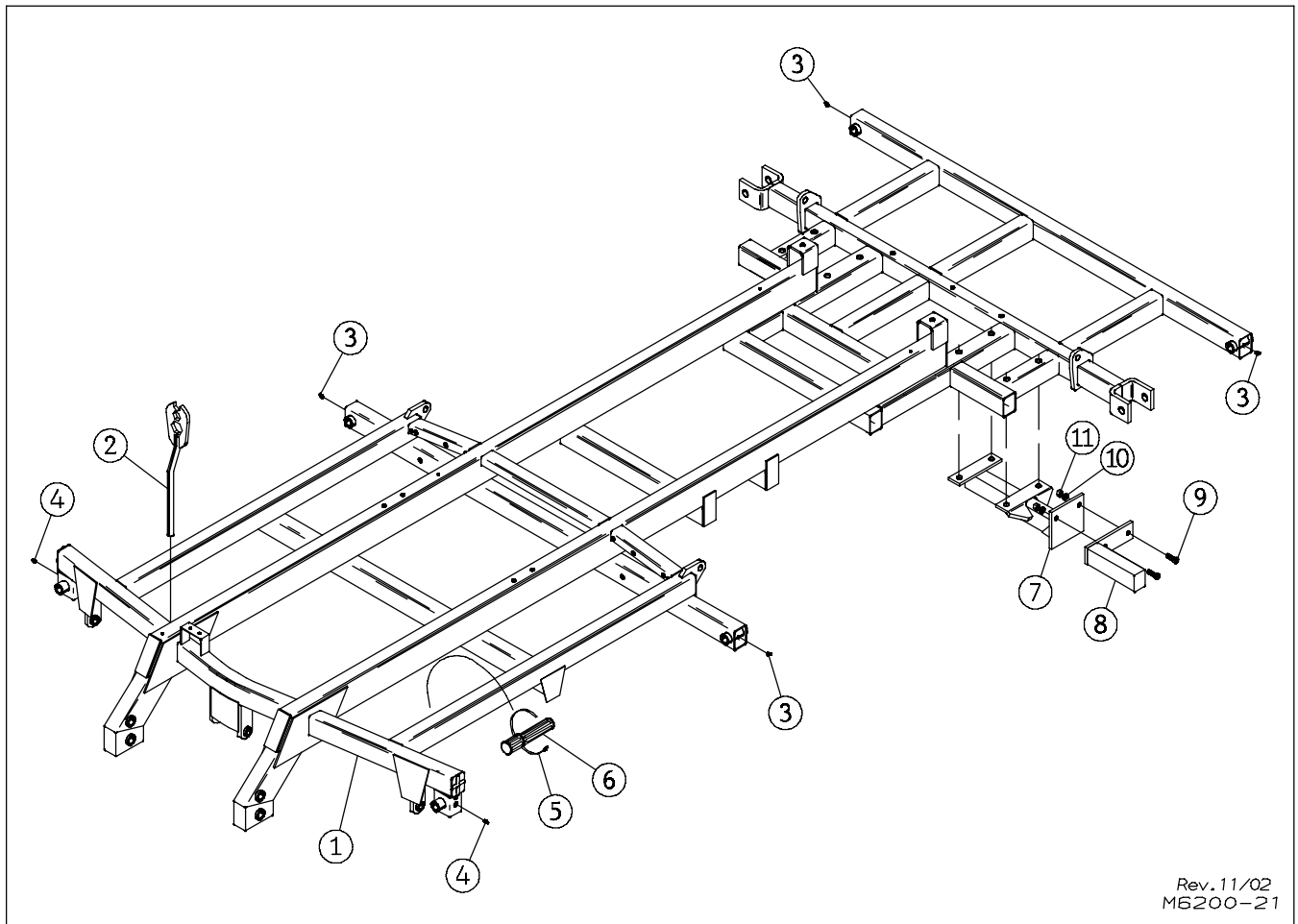

Rev. 11/02
M6200-21

FOR MODELS - TL6200 18, 21, 24

11/02

Item	Part Number	Part Description	Qty.
1	6201-1-0	Main Frame Weldment	1
2	6127-25-0	Tie Rod Wrench	1
3	65-100	1/8NPT x 45 Zerk	4
4	65-101	1/8NPT STD. Zerk	2
5	25-1163	Clamp	1
6	99-218	Owner's Manual Canister	1
7	★ 6200-143-0	Extension Support Weldment	2
8	★ 6337-44-0	Extension Weldment	2
9	★ 62-421	3/4NC x 2" GD5 Cap Screw	4
10	★ 64-112	3/4" STD. Lock Washer	4
11	★ 63-112	3/4NC Hex Nut	4
★ Used for models with 9" Spacing			

NOTE: TOP OF WING STOP MUST
BE PARALLEL TO TOP
OF FRAME.

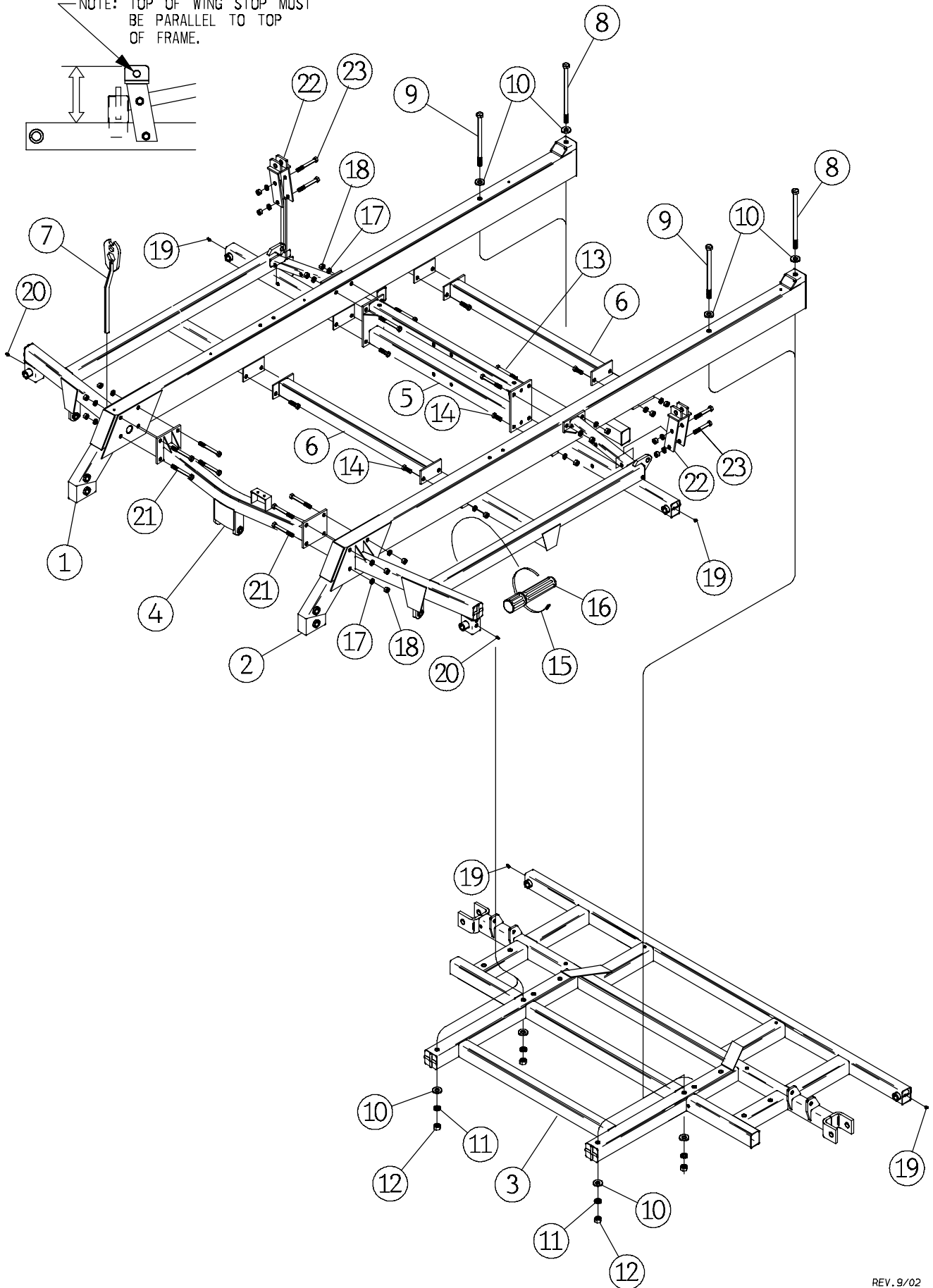

REV. 9/02
M6200-2

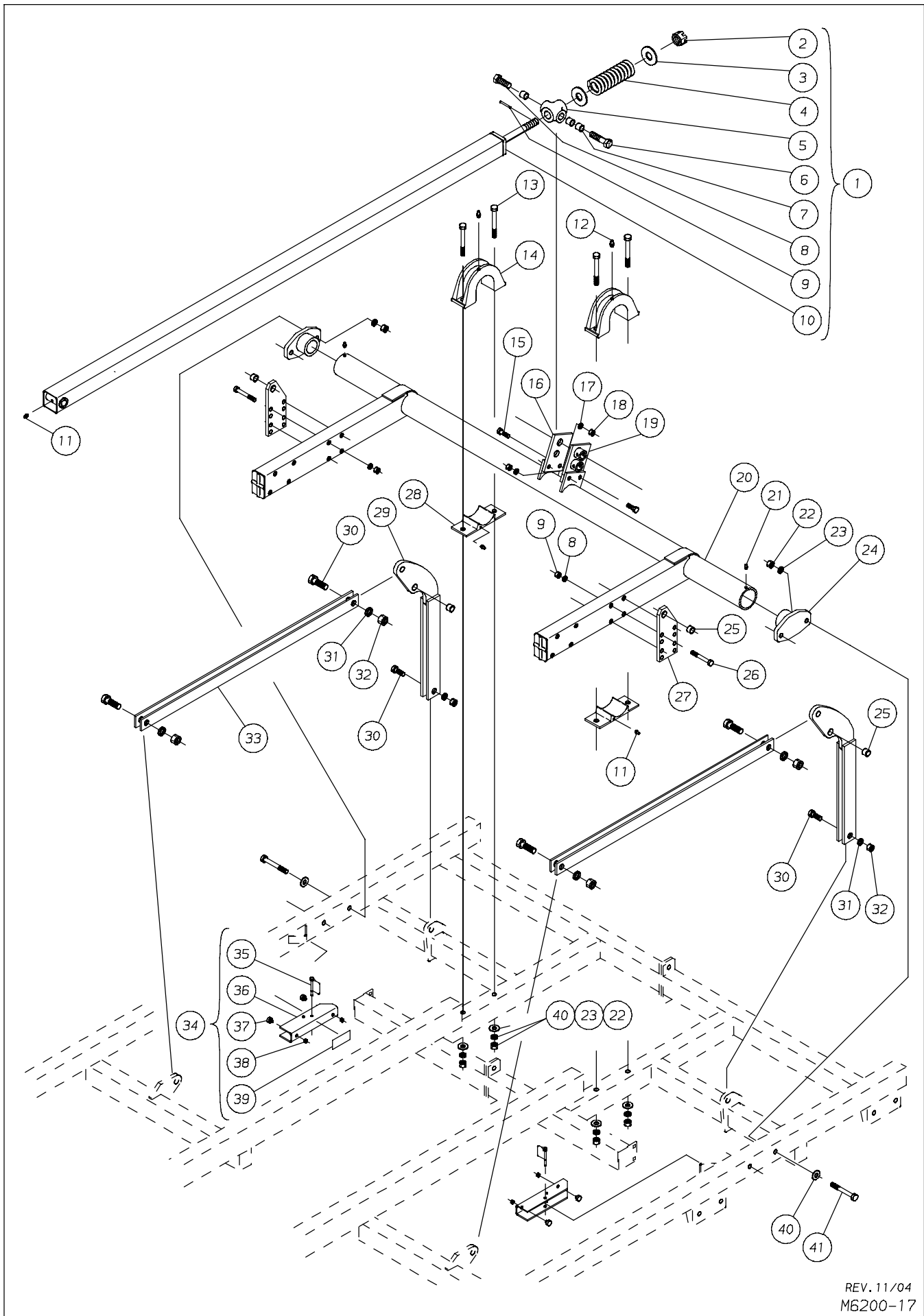

REV. 11/04
M6200-17

CENTER ROCKER

FOR MODELS - TL 6200 9, 12, 15

8/06

<i>Item</i>	<i>Part Number</i>	<i>Part Description</i>	<i>Qty.</i>
1	6201-75-0	Spring Link Assembly (Includes ● Items)	1
2	● 63-128	1-1/2NC Slotted Nut	1
3	● 64-129	1-1/2" STD. Flat Washer	2
4	● 76-164	Spring	1
5	● 2426-35-1	Trunnion	1
6	● 62-237	1NC x 3" Cap Screw	1
7	● 53-102	Wear Sleeve - 1.25"OD x 1.02"ID x 1.00"	3
8	● 62-234	1NC x 2" Cap Screw	1
9	● 60-617	3/8" DIA. x 2-1/2" Roll Pin	1
10	● 6201-76-0	Link Weldment	1
11	65-101	1/8NPT Zerk	3
12	65-103	1/4NPT Zerk	2
13	62-210	3/4NC x 6" GD.5 Cap Screw	4
14	1112-0-7A	Rocker Shaft Clamp	2
15	62-169	5/8NC x 2" GD.5 Cap Screw	4
16	6112-11-1	Lug	1
17	64-109	5/8" STD. Lock Washer	12
18	63-109	5/8NC Hex Nut	12
19	6112-11-0	Lug Weldment	1
20	6112-10-0	Main Rocker Weldment	1
21	65-110	1/8" Drive Zerk	2
22	63-112	3/4NC Hex Nut	8
23	64-112	3/4" STD. Lock Washer	8
24	4122-0-8A	Rocker Bearing	2
25	53-102	Wear Sleeve - 1.25"OD x 1.02"ID x 1.00"	4
26	62-339	5/8NC x 4-1/2" GD.5 Cap Screw	8
27	6127-89-0	Wing Cylinder Lug Assembly	2
28	595-0-11	Rocker Bearing Plate	2
29	6331-86-0	Cylinder Bracket Weldment	2
30	62-237	1NC x 3" Cap Screw	6
31	64-118	1" STD. Lock Washer	6
32	63-117	1NC Hex Nut	6
33	6327-87-0	Cylinder Bracket Link Weldment	2
34	5800-17-0	Road Lock Assembly (Includes ★ Items)	2
35	★ 60-103	5/16" DIA. P.T.O. Pin	1
36	★ 6124-17-1	Road Lock	1
37	★ 44-107	Threaded Bumper	2
38	★ 63-102	3/8NC Hex Nut	2
39	★ 74-387	Road Lock Decal	1
40	64-113	3/4" STD. Flat Washer	8
41	62-207	3/4NC x 5-1/2" GD.5 Cap Screw	4

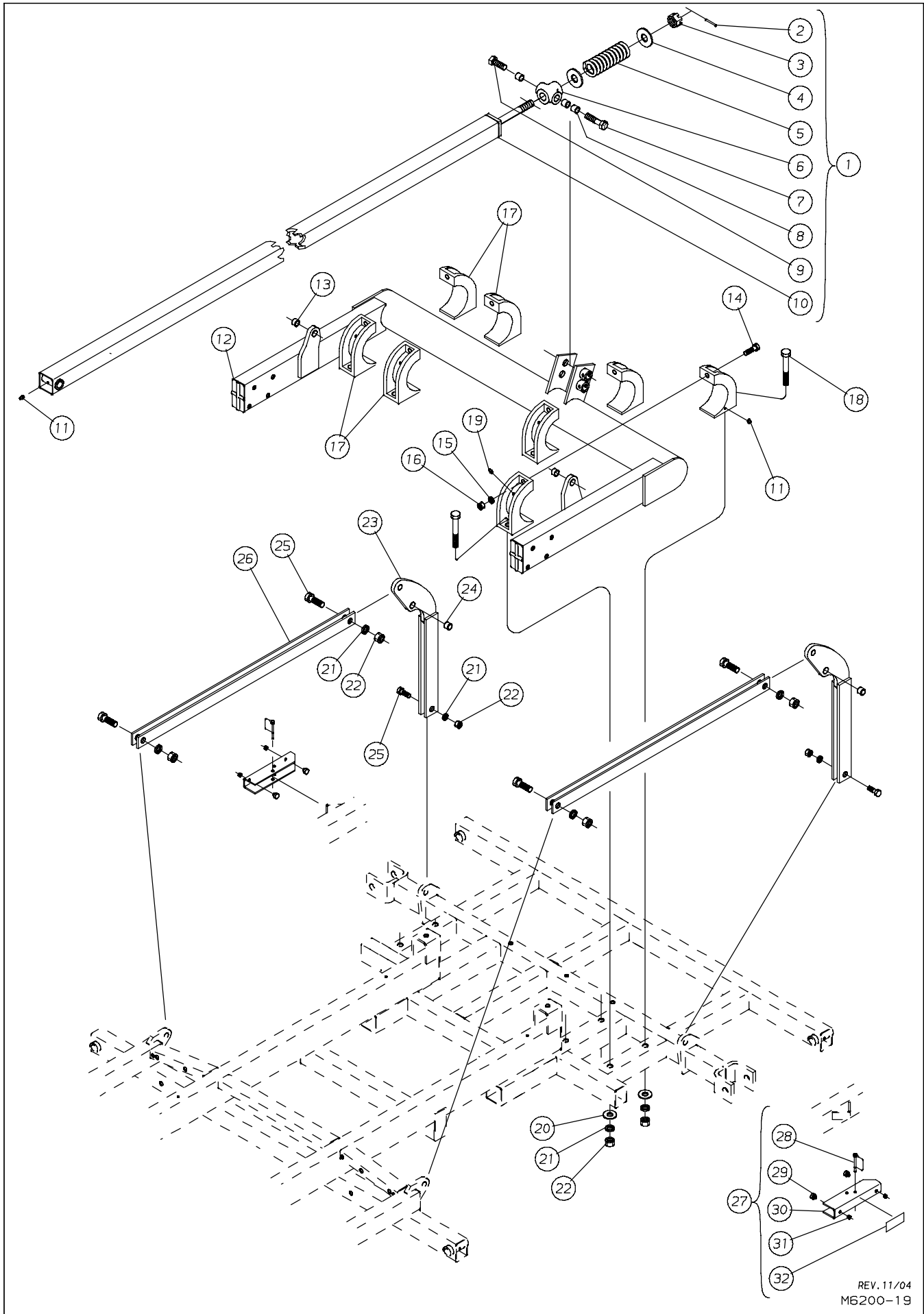

REV. 11/04
M6200-19

CENTER ROCKER

FOR MODELS - TL 6200 18, 21, 24

8/06

<i>Item</i>	<i>Part Number</i>	<i>Part Description</i>	<i>Qty.</i>
1	6201-75-0	Spring Link Assembly (Includes ● Items)	1
2	● 60-617	3/8" DIA. x 2-1/2" Roll Pin	1
3	● 63-128	1-1/2NC Slotted Nut	1
4	● 64-129	1-1/2" STD. Flat Washer	2
5	● 76-164	Spring	1
6	● 2426-35-1	Trunnion	1
7	● 62-237	1NC x 3" Cap Screw	1
8	● 53-102	Wear Sleeve - 1.25"OD x 1.02"ID x 1.00"	3
9	● 62-234	1NC x 2" Cap Screw	1
10	● 6201-76-0	Link Weldment	1
11	65-101	1/8NPT Zerk	6
12	6118-10-0	Main Rocker Weldment	1
13	53-102	Wear Sleeve - 1.25"OD x 1.02"ID x 1.00"	4
14	62-195	3/4NC x 2-1/2" GD.5 Cap Screw	4
15	64-112	3/4" STD. Lock Washer	8
16	63-112	3/4NC Hex Nut	8
17	2145-0-16	Rocker Shaft Clamp Half	8
18	62-253	1NC x 7" GD5 Cap Screw	8
19	65-102	1/8NPT x 90° Zerk	2
20	64-119	1" STD. Flat Washer	8
21	64-118	1" STD. Lock Washer	12
22	63-117	1NC Hex Nut	12
23	6201-86-0	Cylinder Bracket Weldment	2
24	53-102	Wear Sleeve - 1.25"OD x 1.02"ID x 1.00"	2
25	62-237	1NC x 3" Cap Screw	4
26	6327-87-0	Cylinder Bracket Link Weldment	2
27	5800-17-0	Maintenance Lock Assembly (Includes ★ Items)	2
28	★ 60-103	5/16" DIA. P.T.O. Pin	1
29	★ 6124-17-1	Maintenance Lock	1
30	★ 44-107	Threaded Bumper	2
31	★ 63-102	3/8NC Hex Nut	2
32	★ 74-387	Road Lock Decal	1

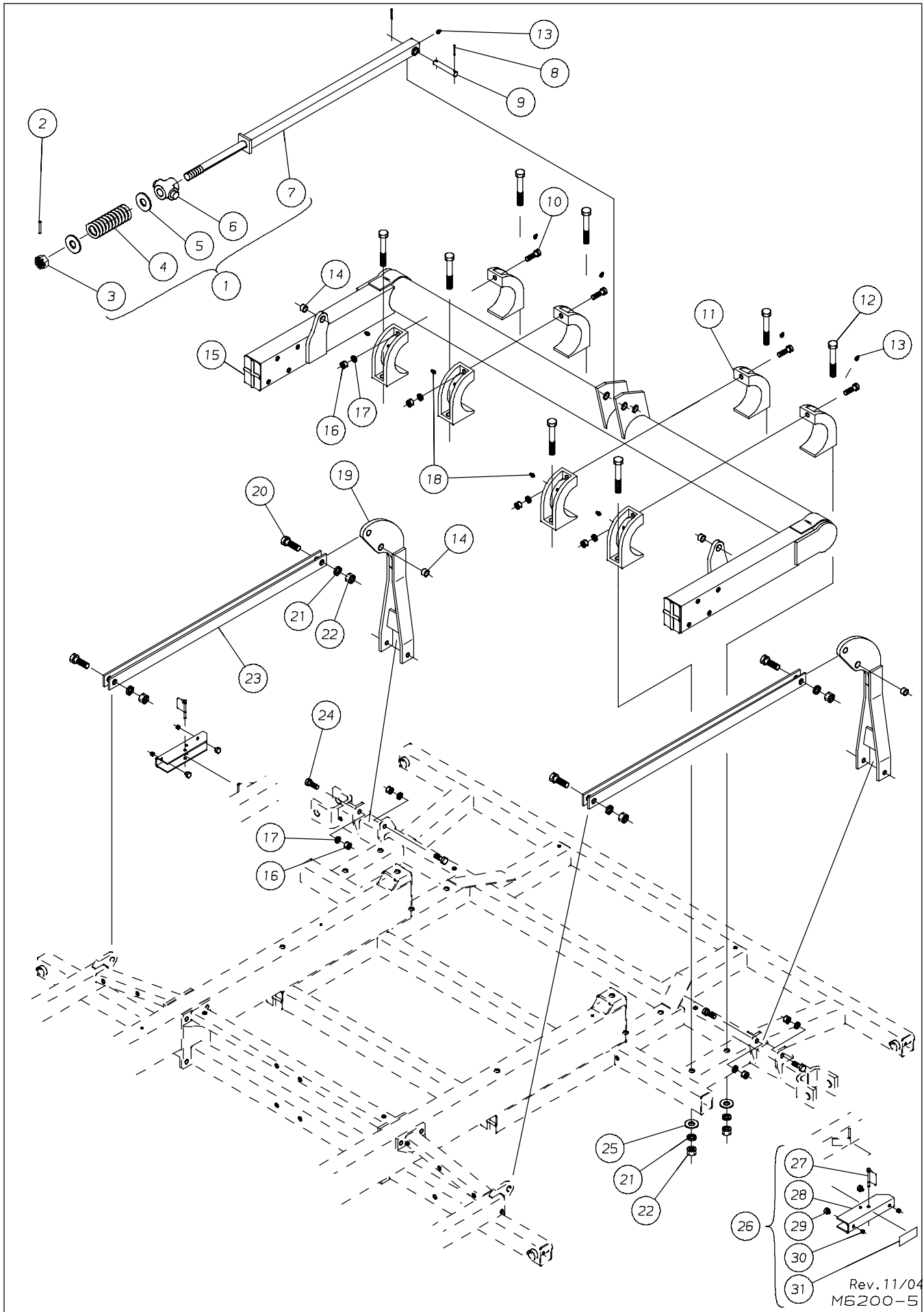

Rev. 11/04
M6200-5

CENTER ROCKER

FOR MODELS - TL 6200 27, 31, 36, 42 45

8/06

<i>Item</i>	<i>Part Number</i>	<i>Part Description</i>	<i>Qty.</i>
1	6202-55-0	Leveling Link Assembly (includes ● parts)	1
2	● 60-617	3/8" DIA. x 2-1/2" Roll Pin	1
3	● 63-128	1-1/2NC Slotted Nut	1
4	● 2145-52-1	Trunnion	1
5	● 64-129	1-1/2" STD. Flat Washer	2
6	● 76-164	Spring	1
7	● 6202-56-0	Link Weldment	1
8	60-606	1/4" DIA. x 2" Roll Pin	2
9	6127-0-11	Top Link Pin	1
10	62-195	3/4NC x 2-1/2" GD5 Cap Screw	4
11	2145-0-16	Rocker Shaft Clamp Half	8
12	62-253	1NC x 7" GD5 Cap Screw	8
13	65-101	1/8NPT Zerk	9
14	53-102	Wear Sleeve - 1.25"OD x 1.02"ID x 1.00"	4
15	6202-10-0	Main Rocker Weldment	1
16	63-112	3/4NC Hex Nut	8
17	64-112	3/4" STD. Lock Washer	8
18	65-102	1/8NPT x 90° Zerk	2
19	6202-86-0	Cylinder Bracket Weldment	2
20	62-237	1NC x 3" Cap Screw	4
21	64-118	1" STD. Lock Washer	12
22	63-117	1NC Hex Nut	12
23	6327-87-0	Cylinder Bracket Link Weldment	2
24	62-421	3/4NC x 2" GD.5 Cap Screw	4
25	64-119	1" STD. Flat Washer	4
26	5800-17-0	Maintenance Lock Assembly (Includes ★ Items)	2
27	★ 60-103	5/16" DIA. P.T.O. Pin	1
28	★ 6124-17-1	Lock Channel	1
29	★ 44-107	Threaded Bumper	2
30	★ 63-102	3/8NC Hex Nut	2
31	★ 74-387	Lock Decal	1

USE UPPER HOLE FOR
TRACTORS WITH DRAWBAR
18" OR HIGHER.

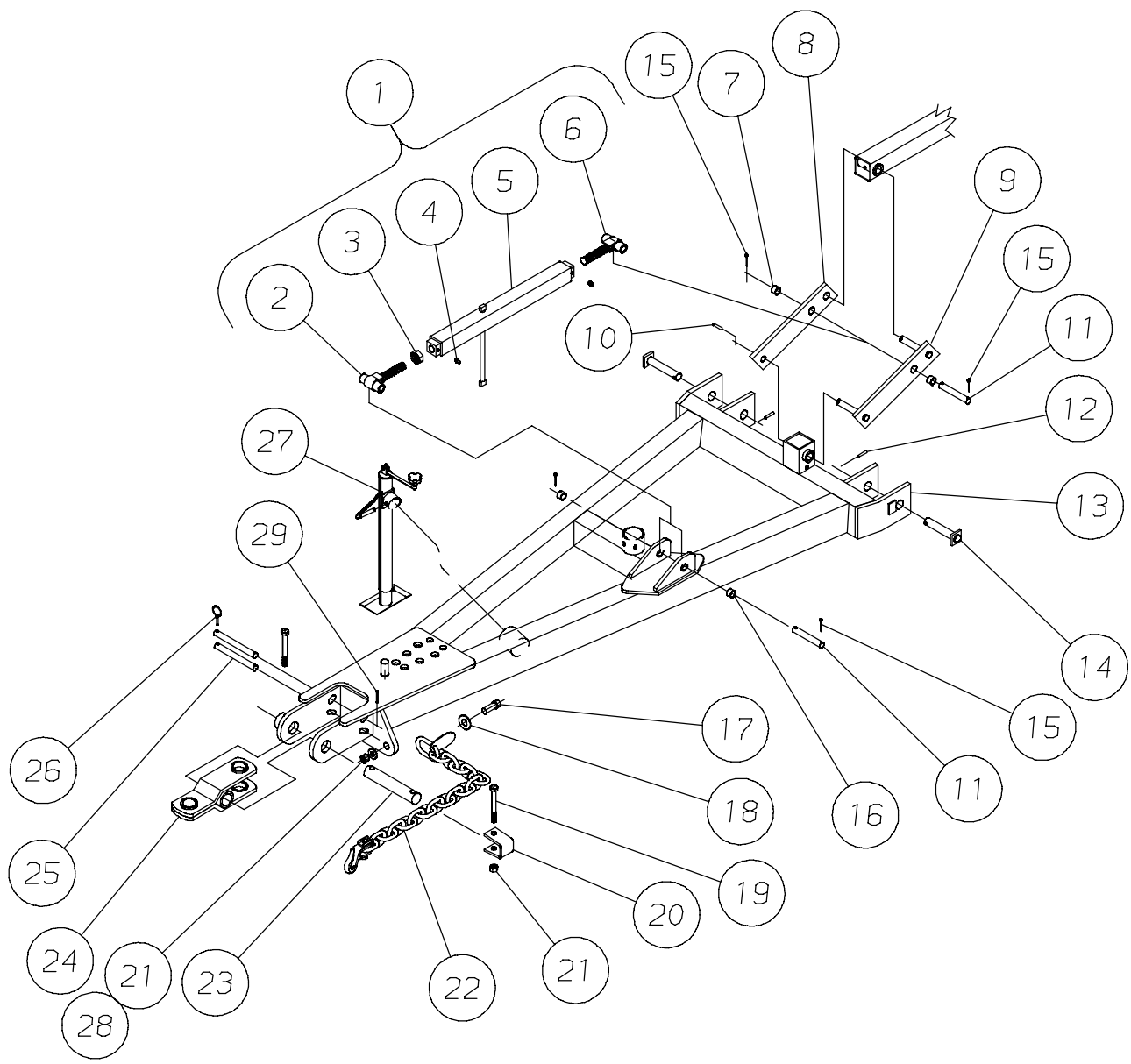
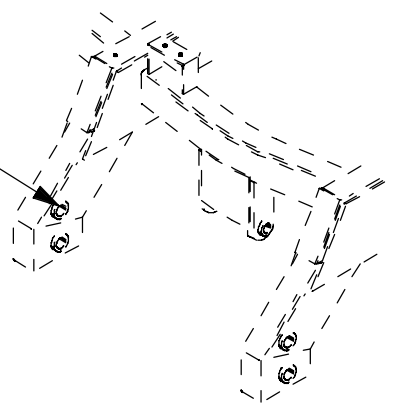

Rev. 9/03
M6200-4

USE UPPER HOLE FOR
TRACTORS WITH DRAWBAR
18" OR HIGHER.

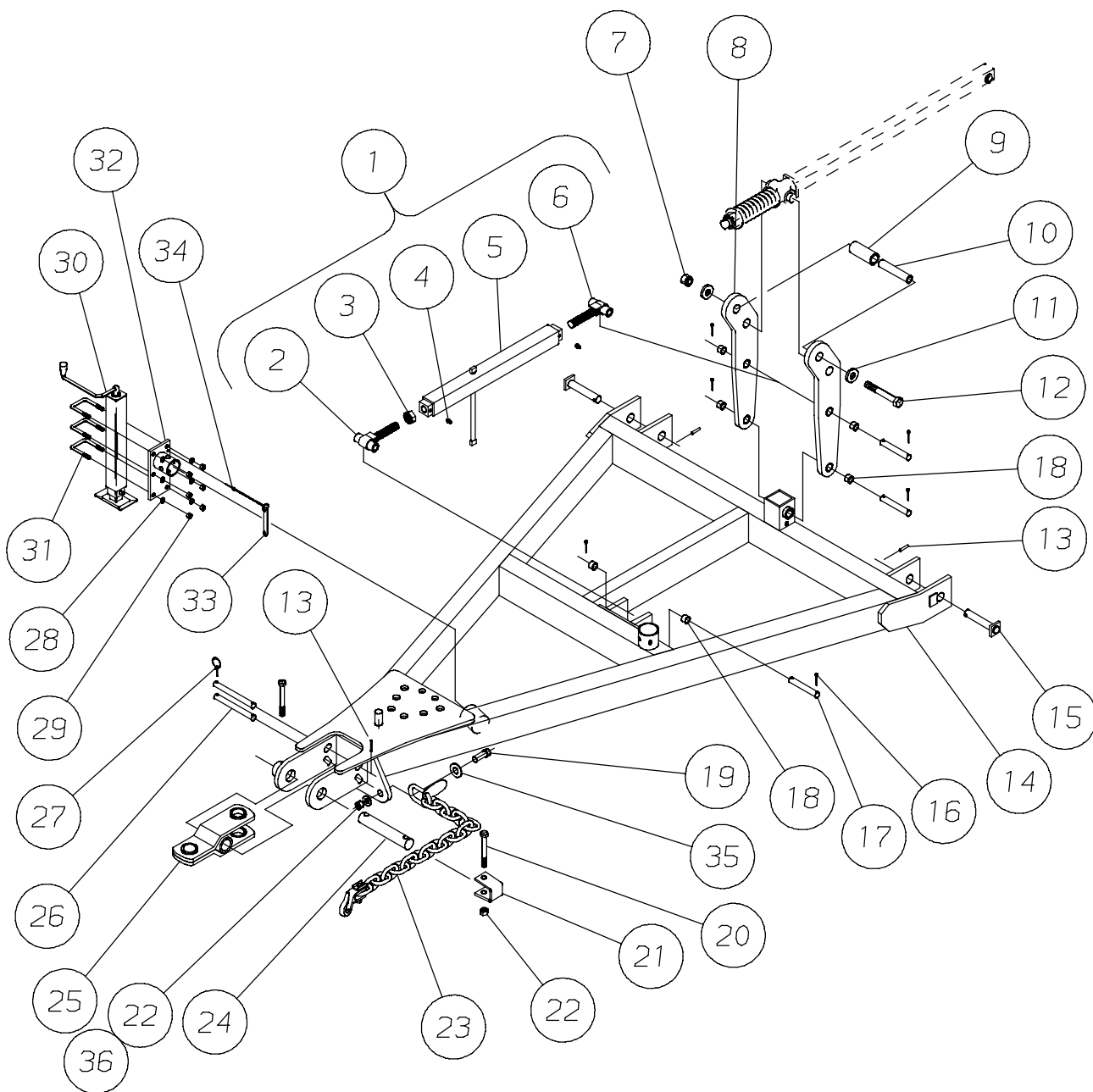
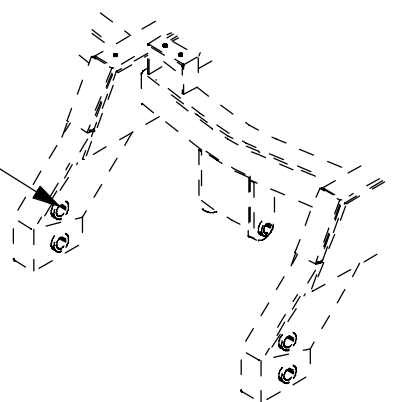

Rev. 9/03
M6200-6

TONGUE & JACK ASSEMBLY

FOR MODELS - TL 6200 27, 31, 36, 42, 45

9/03

<i>Item</i>	<i>Part Number</i>	<i>Part Description</i>	<i>Qty.</i>
1	6142-80-0	Turnbuckle Assembly	1
2	6142-82-0	Right Hand Threaded End	1
3	63-129	1-1/2NC Hex Jam Nut	1
4	65-101	1/8" STD. Zerk	2
5	6142-81-0	Turnbuckle Body	1
6	6142-83-0	Left Hand Threaded End	1
7	63-119	1NC Lock Nut	1
8	6202-33-0	Connector Lug Assembly (Includes (2) Item 18 Wear Sleeves)	2
9	6202-0-1	Outside Spacer	1
10	6202-0-2	Inside Spacer	1
11	64-119	1" STD. Flat Washer	2
12	62-255	1NC x 7-1/2" GD5 Cap Screw	1
13	60-615	3/8" DIA. x 2" Roll Pin	2
14	6202-30-0	Tongue Weldment	1
15	6127-83-0	Tongue Pin Weldment	2
16	60-606	1/4" DIA. x 2" Roll Pin	6
17	6127-0-11	Turnbuckle Pin	3
18	53-113	Wear Sleeve - 1.50"OD x 1.28"ID x .75"	6
19	62-197	3/4NC x 3" GD5 Cap Screw	1
20	62-201	3/4NC x 4" GD5 Cap Screw	2
21	5630-0-2	Chain Clevis	1
22	63-114	3/4NC Lock Nut	3
23	● 72-352	20,000# Safety Chain	1
	★ 72-356	30,000# Safety Chain	1
24	6200-0-1	Hitch Pin	1
25	5630-75-0	Flip Hitch Weldment (2")	1
26	5630-0-12	Pin	2
27	60-101	P.T.O. Lock Pin	2
28	64-107	1/2" STD. Lock Washer	6
29	63-106	1/2NC Hex Nut	6
30	73-111	Jack Assembly	1
31	61-172	U-Bolt - 1/2"DIA x 2-9/16"W x 3-3/4"L	3
32	4956-55-0A	Jack Mounting Bracket Weldment	1
33	60-106	Fas Pin w/ Chain	1
34	60-702	3/16" DIA. x 1-1/2" Cotter Pin	1
35	4881-9035-1	Special Washer - 3-1/2"OD x 13/16"ID x 1/4"	1
36	64-113	3/4" STD. Flat Washer	1
● Used For Models TL6200 27, 31, 36			
★ Used For Models TL6200 42, 45			

CUSHION TONGUE ASSEMBLY (OPTION)

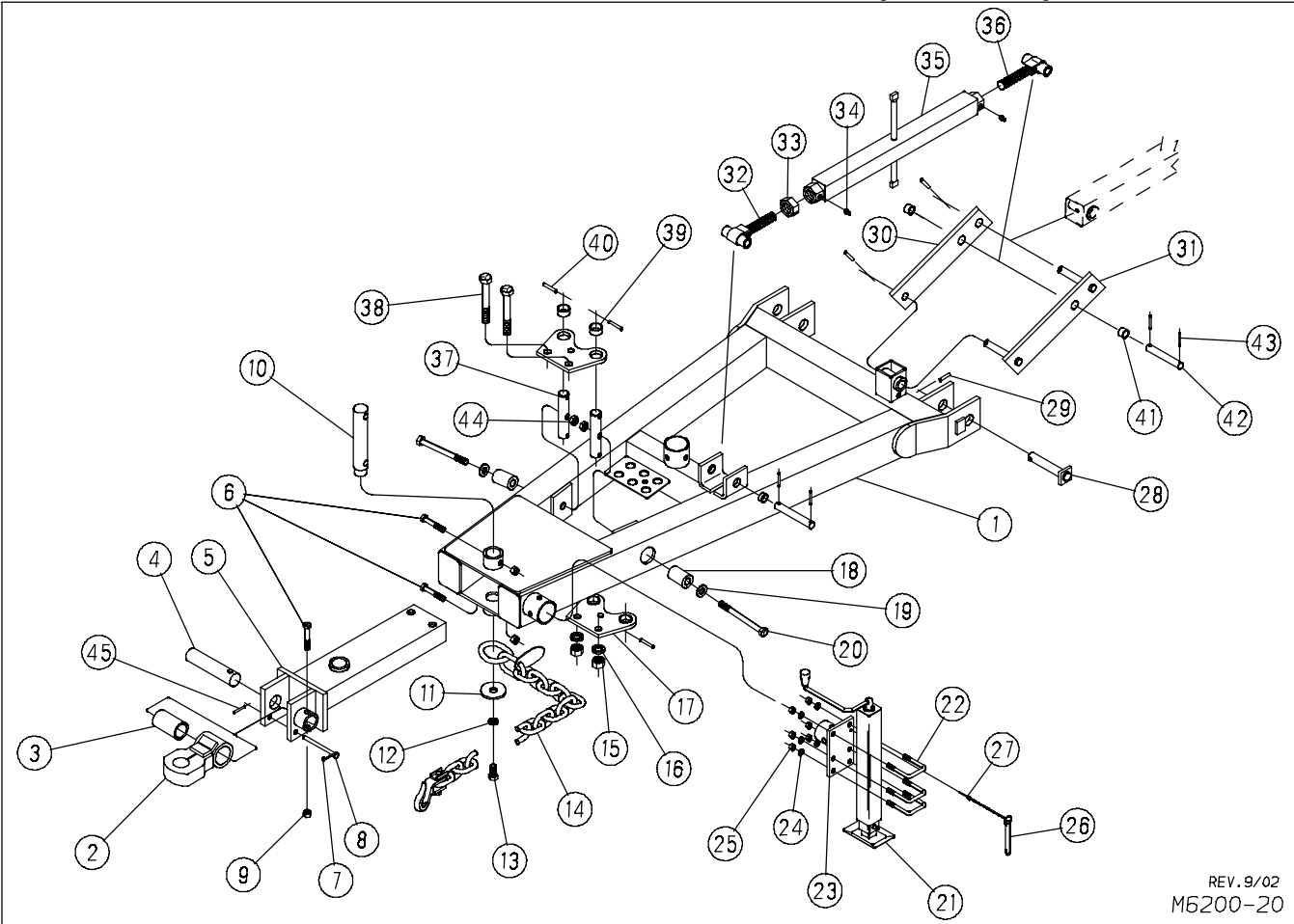

FOR MODELS - TL6200 9, 12, 15, 18, 21 & 24

9/02

Item	Part Number	Part Description	Qty.
1	6324-30-0	Tongue Weldment	1
2	3113-54-0	Tongue Hitch (1-9/16")	1
3	4885-0-6	Hitch Bushing	1
4	4885-0-5	Hitch Pin	1
5	4881-9032-0	Hitch Weldment	1
6	62-176	5/8NC x 3-1/2"GD5 Cap Screw	3
7	60-716	#3 Hair Pin Cotter	1
8	6200-90-0	Clevis Pin (Includes Items 7 & 45)	1
9	63-110	5/8NC Lock Nut	3
10	4881-0000-3	Hitch Pin	1
11	4881-9035-1	Special Washer, 3.5"x .81" x .25"	1
12	64-112	3/4" STD. Lock Washer	1
13	62-191	3/4NC x 1-1/2" GD5 Cap Screw	1
14	72-352	20,000# Safety Chain	1
15	63-117	1NC Hex Nut	2
16	64-118	1" STD. Flat Washer	2
17	4881-7086-0A	Hitch Shock Mount	2
18	76-231	Urethane Spring, 2" x 1" x 2.75"	2
19	64-215	Special Washer, 2" x .81" x .25"	2
20	62-301	3/4NC x 8" GD5 Cap Screw	2
21	73-111	Jack	1
22	61-172	U-Bolt, .50" D. x 2.56"W x 3.75"L	3
23	4956-55-0A	Jack Mounting Bracket Weldment	1

Item	Part Number	Part Description	Qty.
24	64-107	1/2" STD. Lock Washer	6
25	63-106	1/2NC Hex Nut	6
26	60-106	Fas-Pin w/ Chain	1
27	60-702	3/16"DIA x 1-1/2" Cotter Pin	1
28	6118-83-0	Tongue Pin Weldment	2
29	60-614	3/8" DIA.x 1-3/4" Roll Pin	2
30	6118-77-0	Strap	1
31	6127-76-0	Link Weldment	1
32	6127-78-0	Right Hand Threaded End	1
33	63-124	1-1/4NC Hex Jam Nut	1
34	65-101	1/8" STD. Zerk	2
35	6127-77-0	Jack Body	1
36	6127-79-0	Left Hand Threaded End	1
37	4881-0000-5	Pivot Pin	2
38	62-250	1NC x 6-1/2" Cap Screw	2
39	53-166	Wear Sleeve	4
40	60-616	3/8" DIA. x 2-1/4" Roll Pin	4
41	53-116	Wear Sleeve	4
42	3950-0-2	Pin	2
43	60-605	1/4" DIA. x 1-1/2" Roll Pin	4
44	63-113	3/4NC Hex Jam Nut	2
45	60-626	3/16" DIA. x 1-1/2" Roll Pin	1

CUSHION TONGUE ASSEMBLY (OPTION)

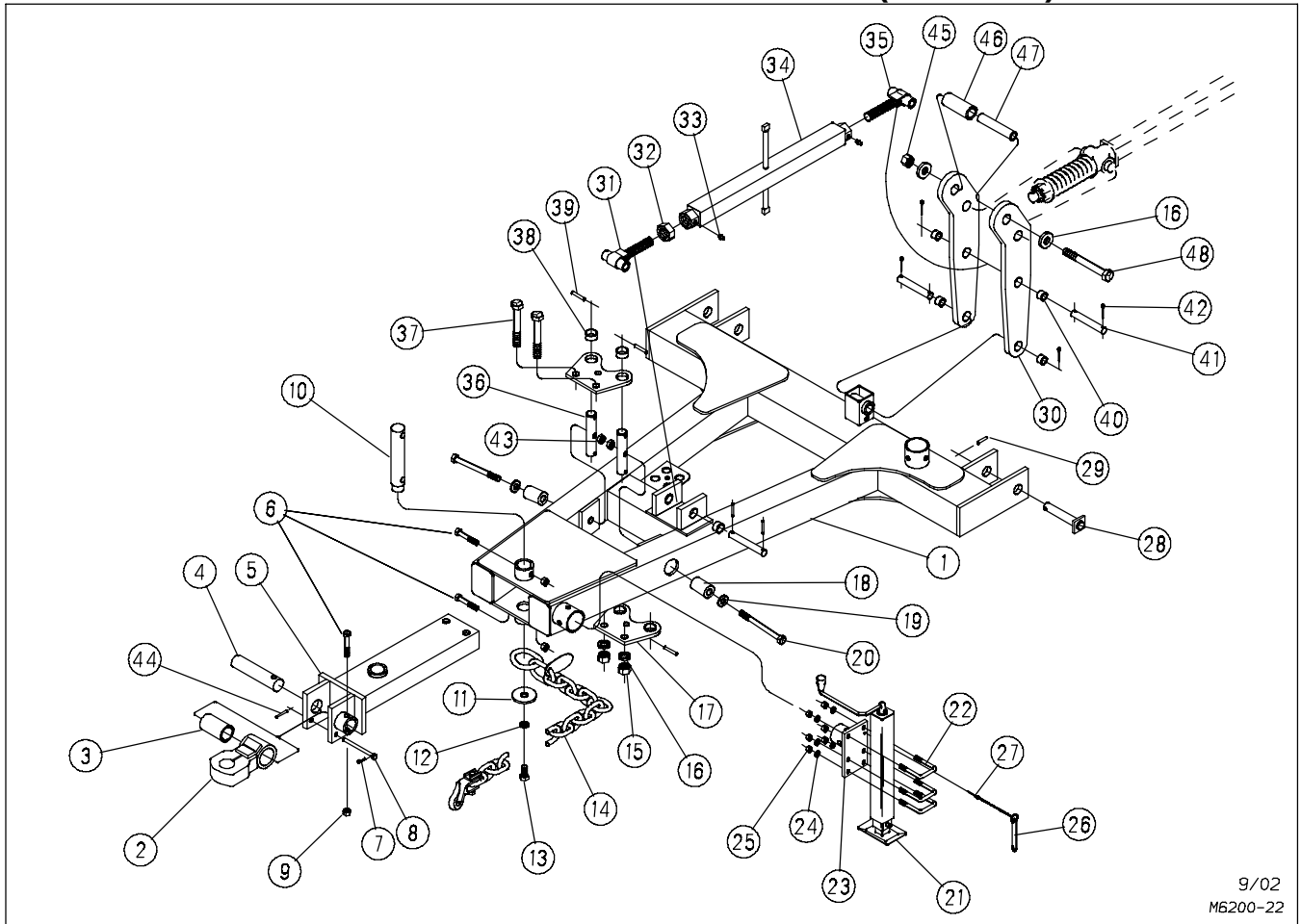

9/02
M6200-22

FOR MODELS - TL6200 27, 31, 36, 42, 45

9/03

Item	Part Number	Part Description	Qty.	Item	Part Number	Part Description	Qty.
1	6345-30-0	Tongue Weldment	1	25	63-106	1/2NC Hex Nut	6
2	2135-54-0	Hitch	1	26	60-106	Fas-Pin w/ Chain	1
3	4885-0-6	Hitch Bushing	1	27	60-702	3/16"DIA. x 1-1/2" Cotter Pin	1
4	4885-0-5	Hitch Pin	1	28	6127-83-0	Tongue Pin Weldment	2
5	4881-9032-0	Hitch Weldment	1	29	60-615	3/8" DIA. x 2" Roll Pin	2
6	62-176	5/8NC x 3-1/2" GD5 Cap Screw	3	30	6202-33-0	Strap Assembly	2
7	60-716	#3 Hair Pin Cotter	1	31	6142-82-0	Right Hand Threaded End	1
8	6200-90-0	Clevis Pin Assm. (Includes 7 & 44)	1	32	63-129	1-1/2NC Hex Jam Nut	1
9	63-110	5/8NC Lock Nut	3	33	65-101	1/8" STD. Zerk	2
10	4881-0000-3	Hitch Pin	1	34	6142-81-0	TurnbuckleWeldment	1
11	4881-9035-1	Special Washer, 3.5" x .81" x .25"	1	35	6142-83-0	Left Hand Threaded End	1
12	64-112	3/4" STD. Lock Washer	1	36	4881-0000-5	Pivot Pin	2
13	62-191	3/4NC x 1-1/2" GD5 Cap Screw	1	37	62-250	1NC x 6-1/2" Cap Screw	2
14	● 72-352	20,000# Safety Chain	1	38	53-166	Wear Sleeve	4
	■ 72-356	30,000# Safety Chain	1	39	60-616	3/8" DIA. x 2-1/4" Roll Pin	4
15	63-117	1NC Hex Nut	2	40	53-113	Wear Sleeve	4
16	64-118	1" STD. Flat Washer	4	41	6127-0-11	Pin	3
17	4881-7086-0A	Hitch Shock Mount	2	42	60-606	1/4" DIA. x 2" Roll Pin	6
18	76-231	Urethane Spring 2"od x 1"id x 2.75	2	43	63-113	3/4NC Hex Jam Nut	2
19	64-215	Spec. Washer 2"od x .81"id x .25"	2	44	60-626	3/16" DIA. x 1-1/2" Roll Pin	1
20	62-301	3/4NC x 8" GD5 Cap Screw	2	45	63-119	1NC Lock Nut	1
21	73-111	Jack	1	46	6202-0-1	Outside Spacer	1
22	61-172	U-Bolt, .50"D x 2.56"W x 3.75"L	3	47	6202-0-2	Inside Spacer	1
23	4956-55-0A	Jack Mounting Bracket Weldment	1	48	62-255	1NC x 7-1/2"GD5 Cap Screw	1
24	64-107	1/2" STD. Lock Washer	6				

● For Models 27-36 ■ For Models 42 & 45

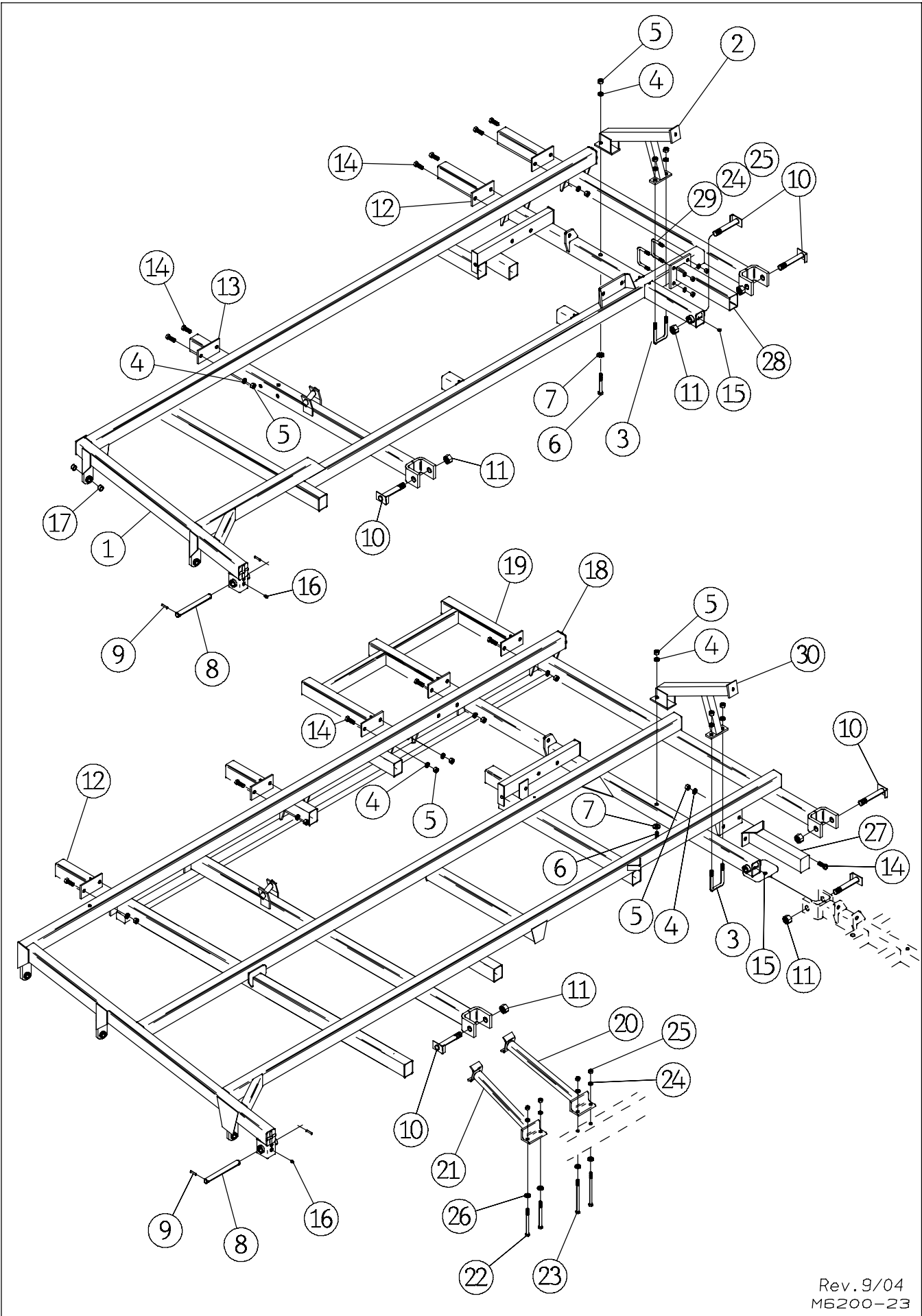

Rev. 9/04
M6200-23

WING FRAME ASSEMBLY

FOR MODELS - TL 6200 18, 21, 24, 27, 31

9/04

<i>Item</i>	<i>Part Number</i>	<i>Part Description</i>	<i>Qty.</i>
1	● 6318-18-0	Right Wing Frame (Shown)	1
	● 6318-20-0	Left Wing Frame	1
2	● 6203-27-0A	Wing Stop Weldment	2
3	61-232	3/4" DIA. U-Bolt	2
4	64-112	3/4" STD. Lock Washer	18
5	63-112	3/4NC Hex Nut	18
6	62-207	3/4NC x 5-1/2" GD5 Cap Screw	2
7	64-113	3/4" STD. Flat Washer	2
8	6127-0-9	Hinge Pin	2
9	60-614	3/8" DIA. x 1-3/4" Roll Pin	4
10	6127-88-0	Hinge Bolt Weldment	6
11	63-126	1-1/4NC Lock Nut	6
12	6112-42-0	Two Shank Extension Weldment	2
13	★ 4122-60-0	One Shank Extension Weldment	2
14	62-421	3/4NC x 2" GD5 Cap Screw	12
15	65-100	1/8NPT x 45° Zerk	2
16	65-101	1/8NPT STD. Zerk	2
17	53-148	Wear Sleeve	4
18	■◆ 6202-18-0	Right Wing Frame (Shown)	1
	■◆ 6202-20-0	Left Wing Frame	1
19	⦿ 6331-35-0	Extension Weldment	2
20	◆ 6127-28-0	Wing Stop Weldment	2
21	■ 6118-28-0	Wing Stop Weldment	2
22	■ 62-433	5/8NC x 7-1/2" GD5 Cap Screw	2
23	◆ 62-546	5/8NC x 9-1/2" GD5 Cap Screw	2
24	64-109	5/8" STD. Lock Washer	12
25	63-109	5/8NC Hex Nut	12
26	64-110	5/8" STD. Flat Washer	4
27	■◆ 6200-42-0	Extension Weldment	2
28	● 4237-58-0	Extension Weldment	2
29	● 61-126	5/8"DIA. U-Bolt	4
30	■ 6205-27-0	Wing Stop	2
	◆ 6206-27-0	Wing Stop	2
● Used on Models TL 6200 18 and 21			
★ Used on Model TL 6200 21			
■ Used on Model TL 6200 24			
⦿ Used on Model TL 6200 31			
◆ Used on Models TL 6200 27 and 31			

MODELS TL 6200 18 & 21

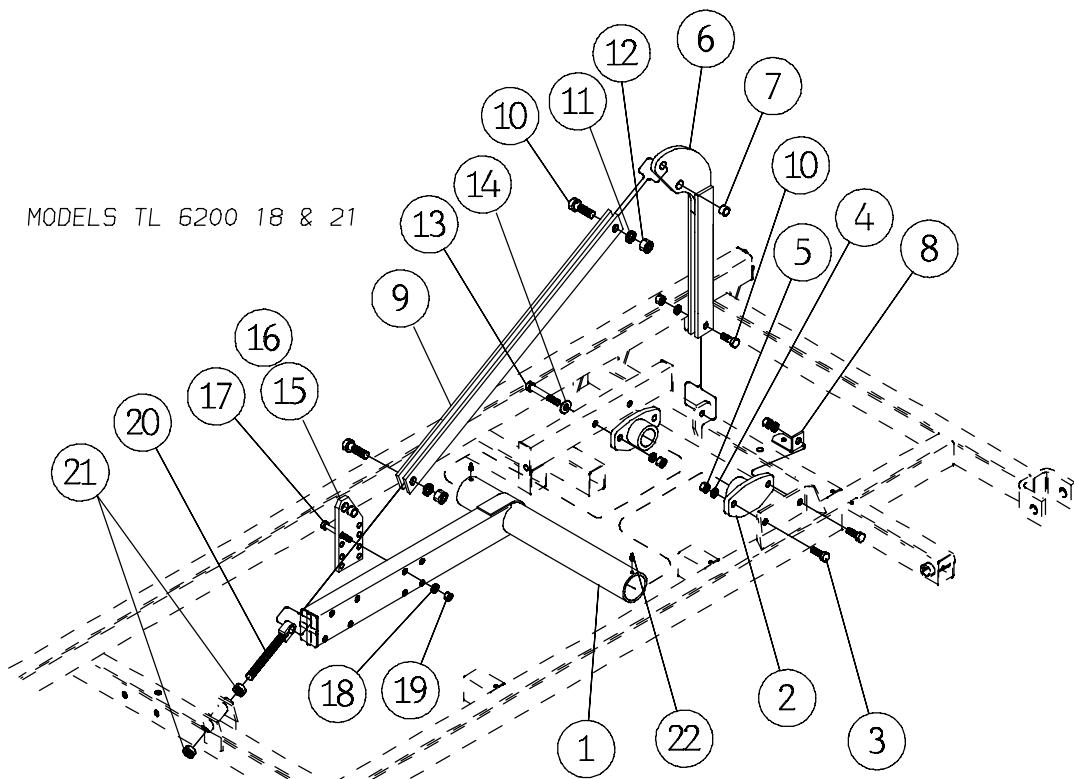

MODELS TL 6200 24, 27, 31

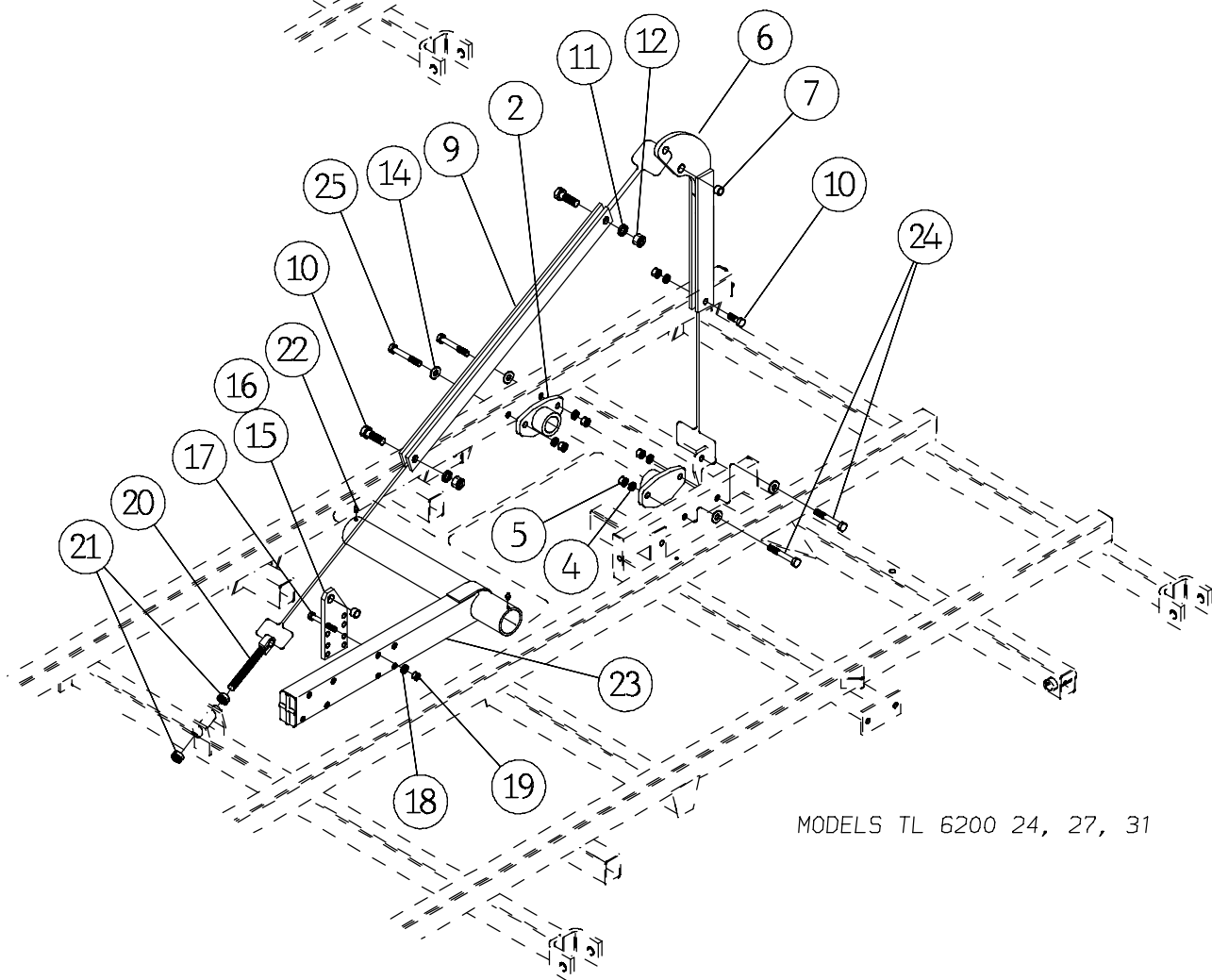

REV 9/02
M6200-265

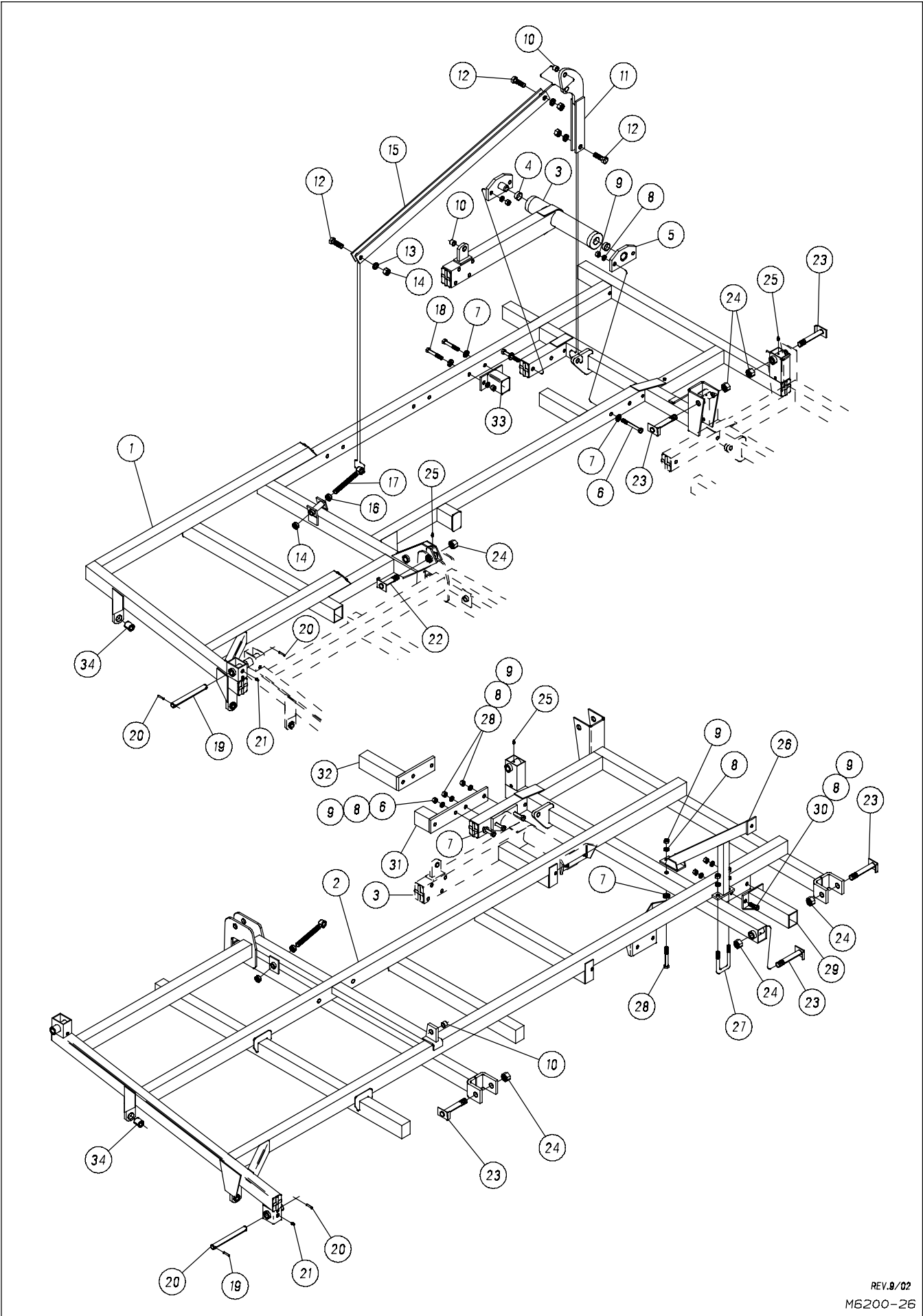

REV.9/02
M6200-26

WING FRAMES & ROCKERS

FOR MODEL - TL 6200 36

9/02

Item	Part Number	Part Description	*Qty.
1	6336-26-0	Right Outer Wing Weldment (SHOWN)	1
	6336-23-0	Left Outer Wing Weldment	1
2	6336-18-0A	Right Inner Wing Weldment (SHOWN)	1
	6336-20-0A	Left Inner Wing Weldment	1
3	6336-12-0	Right Wing Rocker Weldment (SHOWN)	2
	6336-13-0	Left Wing Rocker Weldment	2
4	53-110	Wear Sleeve - 2.00"od x 1.81"id x 1.50"	8
5	6336-35-0	Rocker Pivot Weldment	8
6	62-205	3/4NC x 5" GD5 Cap Screw	10
7	64-113	3/4" STD. Flat Washer	20
8	64-112	3/4" STD. Lock Washer	36
9	63-112	3/4NC Hex Nut	36
10	53-102	Wear Sleeve - 1.25"od x 1.00"id x 1.00"	10
11	6136-86-0	Cylinder Bracket Weldment	4
12	62-237	1NC x 3" Cap Screw	12
13	64-118	1" STD. Lock Washer	12
14	63-117	1NC Hex Nut	16
15	6337-87-0	Cylinder Link Weldment	4
16	63-118	1NC Hex Jam Nut	4
17	61-241	Eyebolt Weldment	4
18	62-203	3/4NC x 4-1/2" GD5 Cap Screw	8
19	6127-0-9	Wing Hinge Pin	4
20	60-614	3/8" DIA. x 1-3/4" Roll Pin	8
21	65-101	1/8" STD. Zerk	6
22	6136-88-0	Hinge Pin Weldment	2
23	6127-88-0	Hinge Bolt Weldment	10
24	63-126	1-1/4NC Lock Nut	12
25	65-100	1/8" x 45 Zerk	8
26	6136-34-0A	Wing Stop Weldment	2
27	61-232	U-Bolt, 3/4" DIA.x 3-1/16"W x 5-1/2"L	2
28	62-207	3/4NC x 5-1/2" GD5 cap Screw	6
29	●▲ 6200-42-0	2-Shank Extension Weldment	2
30	62-421	3/4NC x 2" GD5 Cap Screw	8
31	● 6337-42-0	Shank Extension Weldment	2
32	● 6337-44-0	Extension Weldment	2
33	● 4122-60-0	One Shank Extension Weldment	2
34	53-148	Wear Sleeve - 1.25"od x 1.00"id x 1.50"	8
★ Unless otherwise specified, quantities include right and left sides of unit			
● Use with 7" Spacing			
▲ Use with 9" Spacing			

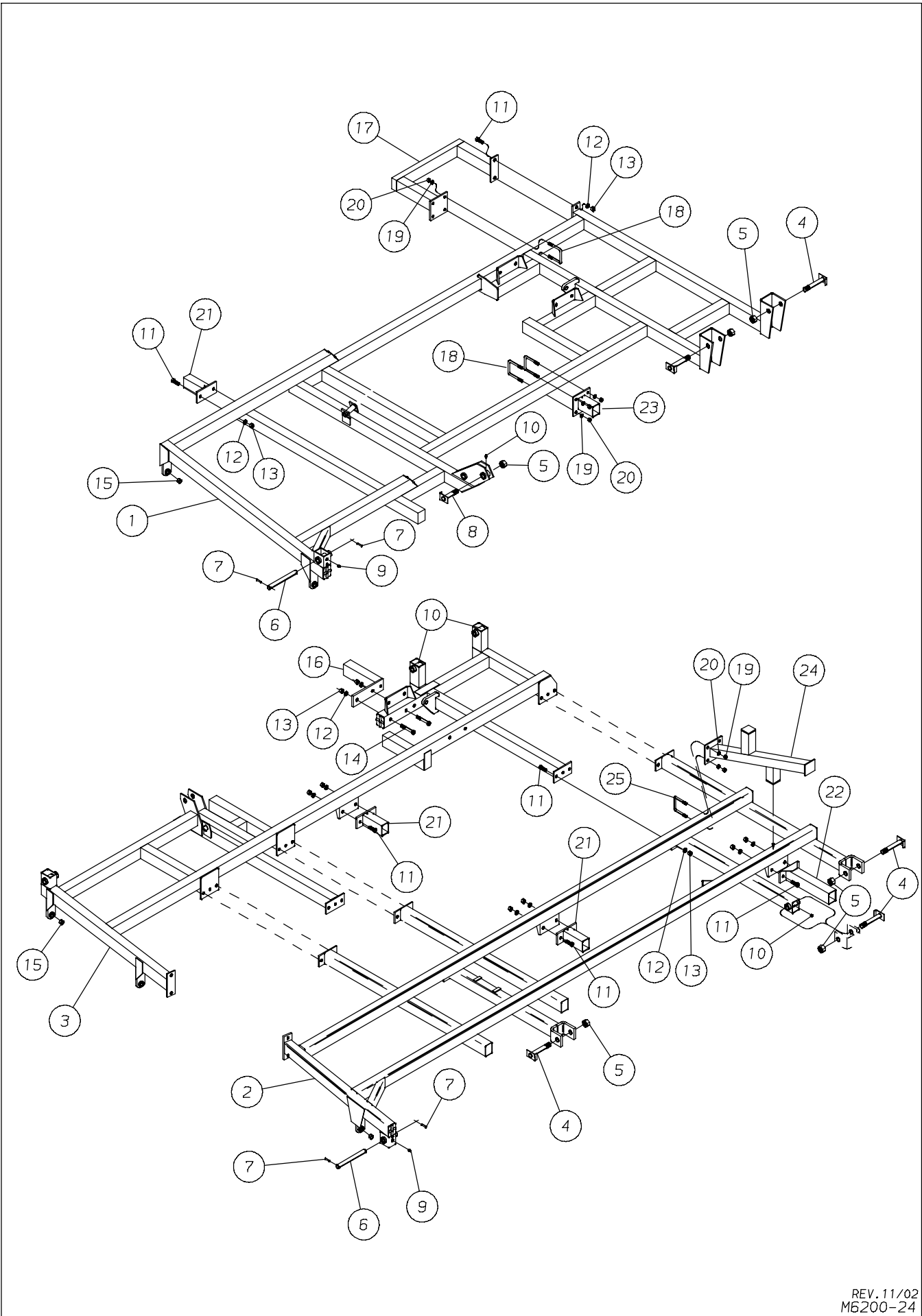

REV. 11/02
M6200-24

WING FRAME ASSEMBLY

FOR MODELS - TL 6200 42 AND 45

9/03

<i>Item</i>	<i>Part Number</i>	<i>Part Description</i>	<i>Qty.</i>
1	6345-26-0	Right Outer Wing Assembly	1
	6345-23-0	Left Outer Wing Assembly	1
2	6345-18-0	Right Inner Wing Assembly	1
	6345-20-0	Left Inner Wing Assembly	1
3	6345-19-0	Right Inner Wing Weldment	1
	6345-21-0	Left Inner Wing Weldment	1
4	6127-88-0	Hinge Bolt Weldment	10
5	63-126	1-1/4NC Hex Nut	12
6	6127-0-9	Hinge Pin	4
7	60-614	3/8" DIA. x 1-3/4" Roll Pin	8
8	6136-88-0	Hinge Pin Weldment	2
9	65-101	1/8" STD. Zerk	6
10	65-100	1/8" x 45° Zerk	8
11	62-421	3/4NC x 2" GD5 Cap Screw	44
12	64-112	3/4" STD. Lock Washer	40
13	63-112	3/4NC Hex Nut	40
14	62-203	3/4NC x 4-1/2" GD5 Cap Screw	4
15	53-148	Wear Sleeve	8
16	6337-44-0	Extension Weldment	2
17	● 6345-72-0	Extension Weldment	2
18	61-155	U-Bolt, 5/8" DIA. x 4-1/16"W x 4-5/8"L	8
19	64-109	5/8" STD. Lock Washer	24
20	63-109	5/8NC Hex Nut	24
21	6210-42-0	Extension Weldment	Spec.
22	6200-42-0	Extension Weldment	Spec.
23	5660-16-0	Extension Weldment	Spec.
24	6345-84-0	Wing Stop Weldment	2
25	61-126	U-Bolt, 5/8" DIA. x 4-1/16"W x 4-3/8"L	4

● Used on Model TL 6200 45 ONLY

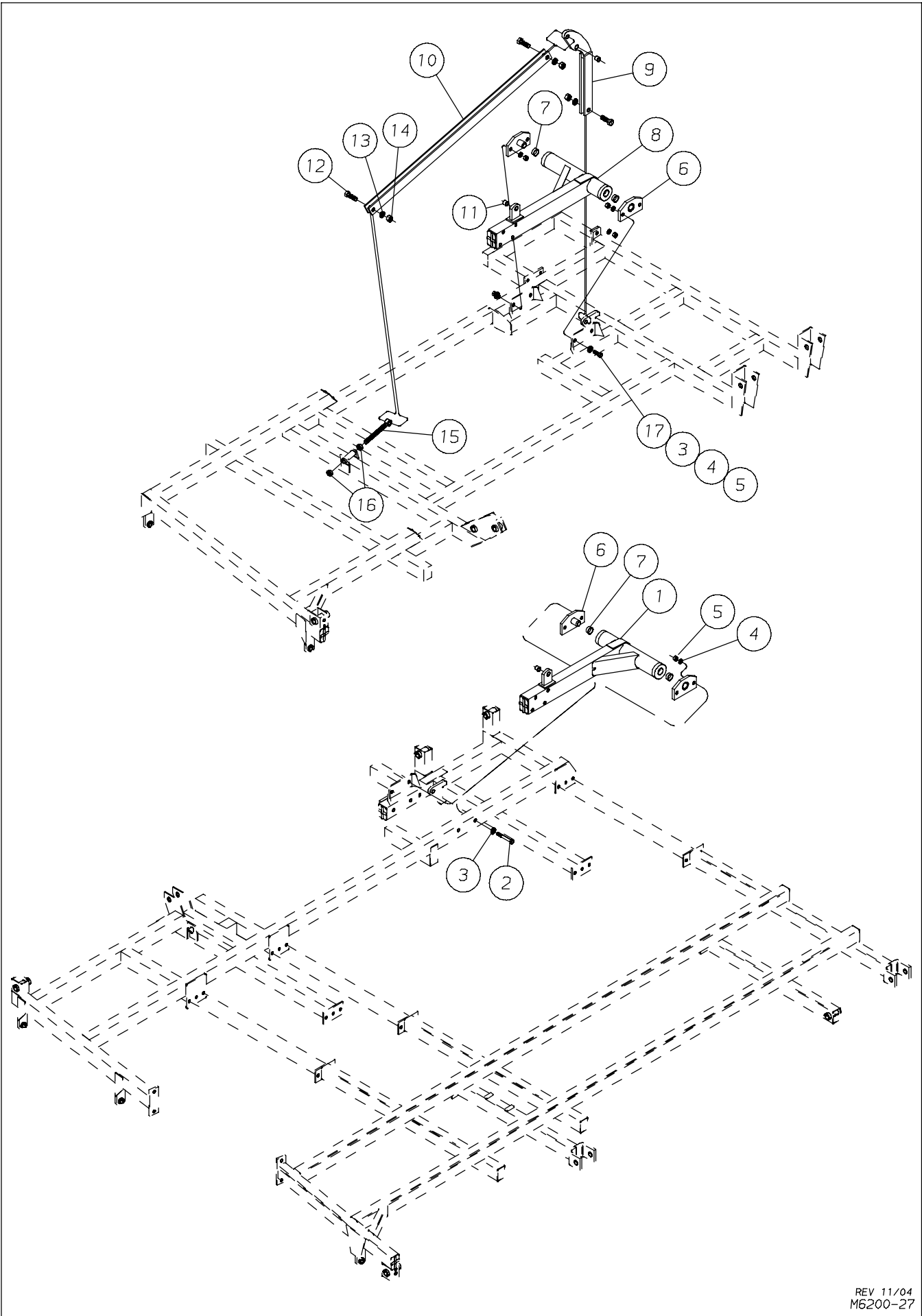

REV 11/04
M6200-27

WING ROCKER

FOR MODELS - TL 6200 42, 45

11/04

<i>Item</i>	<i>Part Number</i>	<i>Part Description</i>	<i>Qty.</i>
1	6345-12-0	Right Wing Rocker Weldment	2
2	62-205	3/4NC x 5" GD5 Cap Screw	4
3	64-113	3/4" STD. Flat Washer	4
4	64-112	3/4" STD. Lock Washer	16
5	63-112	3/4NC Hex Nut	16
6	6336-35-0	Rocker Pivot Weldment	8
7	53-110	Wear Sleeve - 2.00"od x 1.81"id x 1.50"	8
8	6345-13-0	Left Wing Rocker Weldment	2
9	6345-58-0	Cylinder Bracket Weldment	4
10	6209-87-0	Cylinder Link Weldment	4
11	53-102	Wear Sleeve - 1.25"od x 1.02"id x 1.00"	8
12	62-237	1NC x 3" Cap Screw	12
13	64-118	1" STD. Lock Washer	12
14	63-117	1NC Hex Nut	16
15	61-241	1" Eyebolt - 1NC x 10"	4
16	63-118	1NC Hex Jam Nut	4
17	62-421	3/4NC x 2" GD5 Cap Screw	12

WALKING BEAM ASSEMBLY

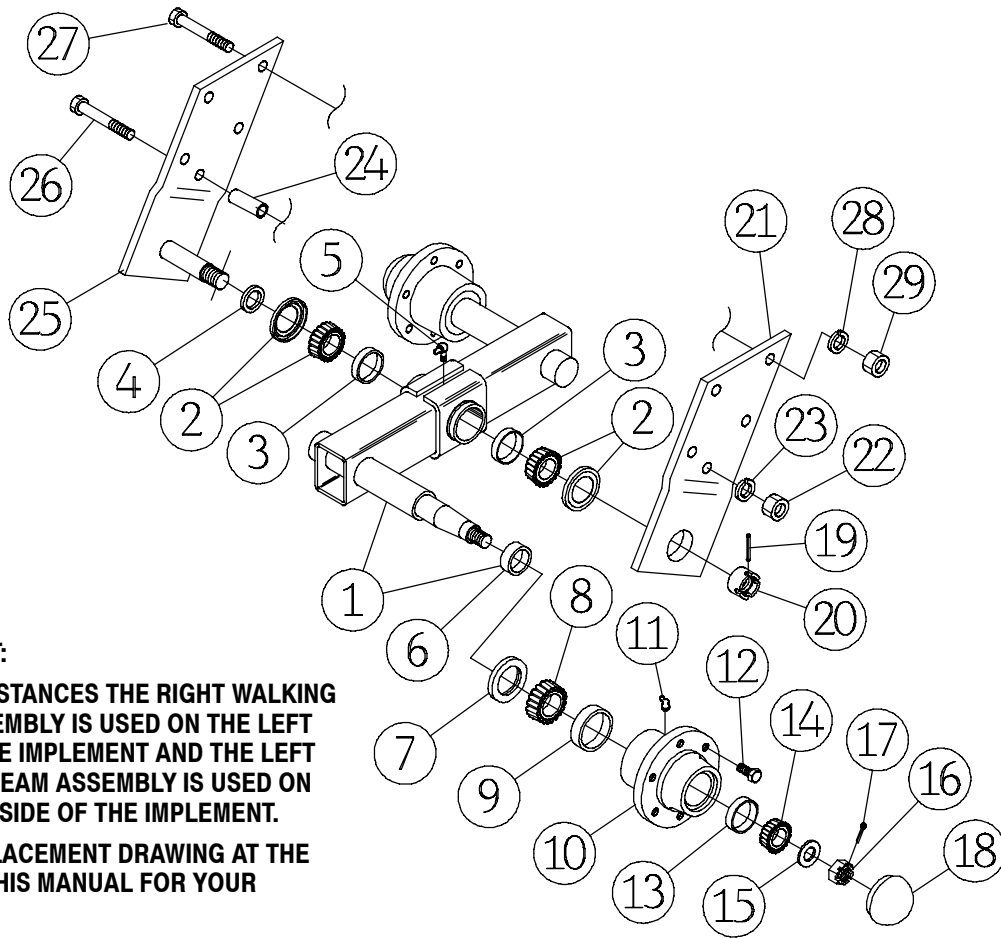

IMPORTANT:

IN SOME INSTANCES THE RIGHT WALKING BEAM ASSEMBLY IS USED ON THE LEFT SIDE OF THE IMPLEMENT AND THE LEFT WALKING BEAM ASSEMBLY IS USED ON THE RIGHT SIDE OF THE IMPLEMENT.

SEE THE PLACEMENT DRAWING AT THE BACK OF THIS MANUAL FOR YOUR MODEL.

REV 11/99
MG100-38

FOR MODELS - TL 6200 9,12, 15 CENTER SECTION
TL 6200 18, 21, 24 CENTER SECTION & WING SECTION
TL 6200 27, 31, 36, 42 & 45 WING SECTION

9/02

Item	Part Number	Part Description	Qty	Item	Part Number	Part Description	Qty
	6127-52-0	Right Walking Beam Assm. Shown	1	17	60-702	3/16"DIA.x 1-1/2" Cotter Pin	1
	6127-53-0	Left Walking Beam Assembly	1	18	52-302	Hub Cap	1
1	6127-54-0	Repair Rt Walking Beam/Sleeve	1	19	60-114	1/4"DIA. x 2 Spiral Expansion Pin	1
	6127-55-0	Repair Lt. Walking Beam/Sleeve	1	20	4218-13-2	Axle Nut	1
2	41-121	Cone & Seal Assembly	2	21	6127-52-1	Left Side Plate	1
3	41-208	Cup	2	22	63-112	3/4NC Hex Nut	1
4	4218-13-3	Special Washer	1	23	64-112	3/4" STD. Lock Washer	1
5	65-107	1/8NPT x 90 Zerk	1	24	6127-52-2	Spacer Tube	1
6	53-105	Wear Ring	2	25	6127-48-0	Right Side Plate	1
7	■ 42-108	Seal	1	26	62-205	3/4NC x 5" GD5 Cap Screw	1
8	■ 41-113	Cone	1	27	* 62-205	3/4NC x 5" GD5 Cap Screw	4
9	■ 41-209	Cup	1	28	* 64-112	3/4" STD. Lock Washer	4
10	● 1918-14-0A	Repair Hub (Includes ● Items)	1	29	* 63-112	3/4NC Hex Nut	4
11	● 65-122	1/4 x 65° Zerk	2				
12	● 62-295	Wheel Bolt	6		1918-84-0	Hub Bearing Kit (Includes ■ Items)	
13	■ 41-208	Cup	1				
14	■ 41-112	Cone	1				
15	64-120	1"SAE Flat Washer	1				
16	63-204	1NF Slotted Hex Nut	1				
* Not Part Of Assembly							

WALKING BEAM ASSEMBLY

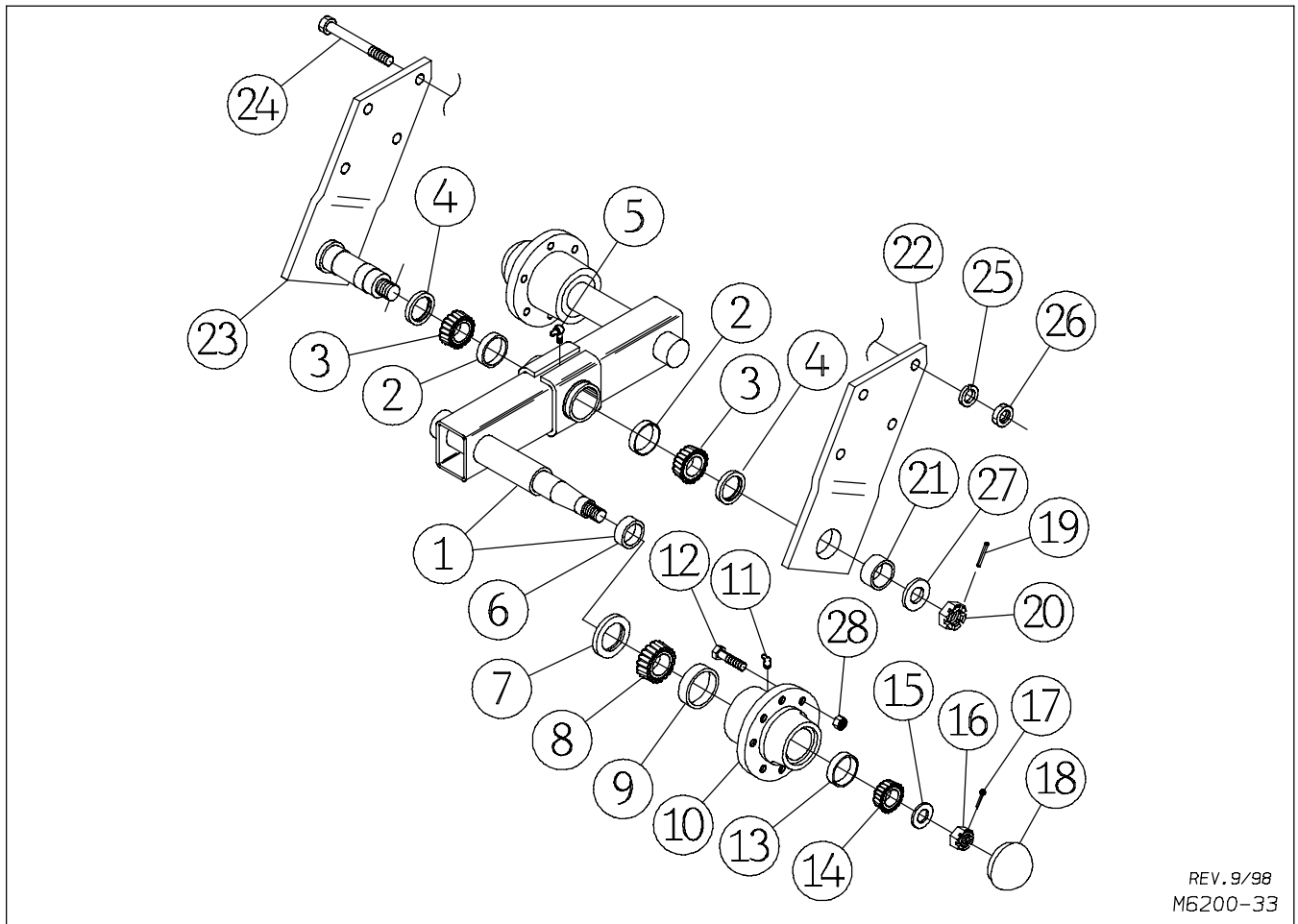

REV. 9/98
M6200-33

FOR MODELS - TL6200 27, 31, 36, 42 & 45 -- CENTER SECTION

9/03

Item	Part Number	Part Description	Qty	Item	Part Number	Part Description	Qty
	6345-79-0	Left Walking Beam Assm.	1	18	52-302	Hub Cap	1
	6345-78-0	Right Walking Beam Assm. Shown	1	19	60-114	1/4"DIA. x 2 Spiral Expansion Pin	1
1	6136-75-0A	Repair Lt Walking Beam/Sleeve	1	20	63-231	1-1/4NF Slotted Hex Nut	1
	6136-76-0A	Repair Rt. Walking Beam/Sleeve	1	21	6136-57-2A	Bushing	1
2	41-210	Cup	2	22	6136-57-1A	Side Plate	1
3	41-114	Cone	2	23	6136-52-0A	Side Plate Weldment	1
4	42-131	Seal	2	24	* 62-213	3/4NC x 6-1/2" GD5 Cap Screw	4
5	65-107	1/8NPT x 90° Zerk	1	25	* 64-112	3/4" STD. Lock Washer	4
6	53-108	Wear Sleeve 2.50od x 1.99id x .75	2	26	* 63-113	3/4NC Hex Jam Nut	4
7	▪ 42-109	Seal	1	27	64-167	Special Washer	1
8	▪ 41-114	Cone	1	28	• 63-208	Wheel Nut	8
9	▪ 41-210	Cup	1				
10	• 2490-95-0	Repair Hub (Includes • Items)	1		2135-84-0	Hub Bearing Kit (Includes ■ Items)	
11	• 65-122	1/4 x 65° Zerk	2				
12	• 62-311	Wheel Bolt	8				
13	▪ 41-208	Cup	1				
14	▪ 41-112	Cone	1				
15	64-120	1"SAE Flat Washer	1				
16	63-204	1NF Slotted Hex Nut	1				
17	60-702	3/16"DIA.x 1-1/2" Cotter Pin	1				
				★ Not Part Of Assembly			

HUB ASSEMBLY

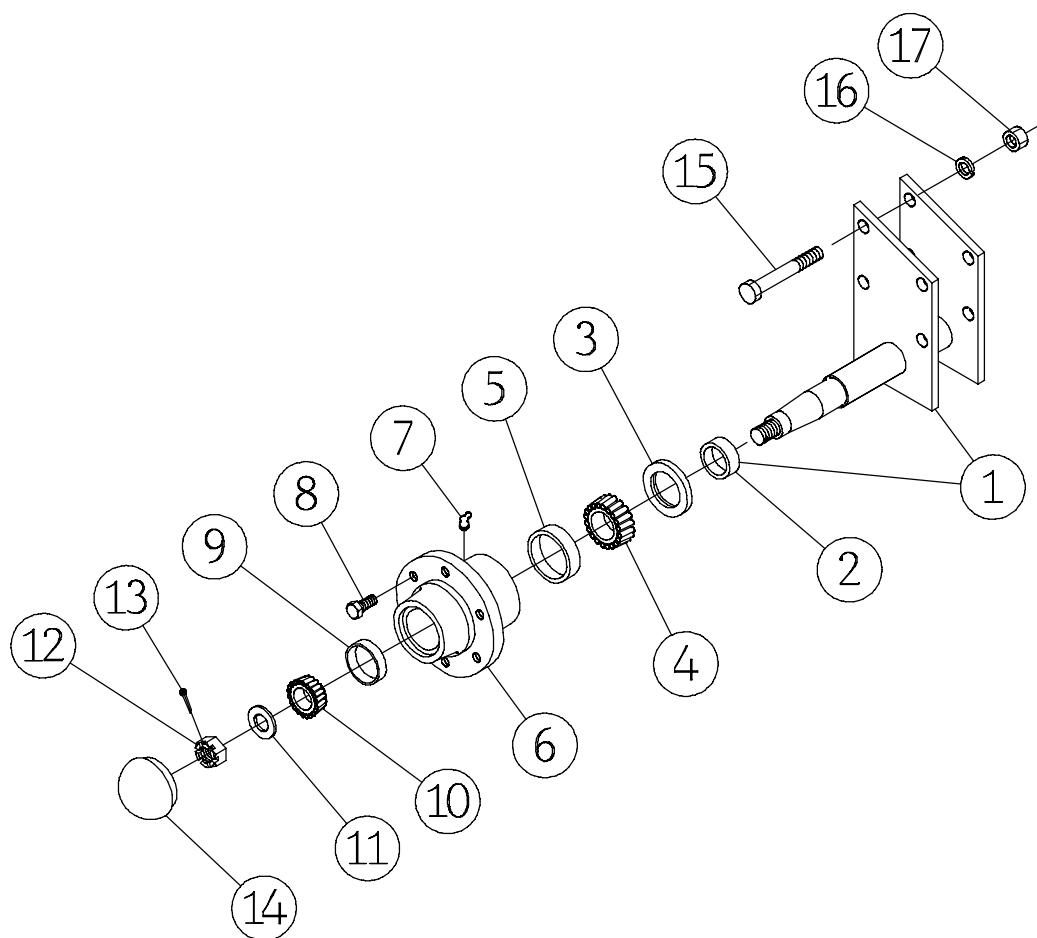

REV. 2/97
ME100-40

FOR MODELS - OPTIONAL FOR TL 6200 18 & 21 WINGS

9/02

Item	Part Number	Part Description	Qty.
	6118-50-0	Single Hub and Axle Assembly - Right (SHOWN)	1
	6118-51-0	Single Hub and Axle Assembly - Left	1
1	6118-54-0	Repair Right Spindle and Sleeve Assembly	1
	6118-55-0	Repair Left Spindle and Sleeve Assembly	1
2	53-105	Wear Ring	1
3	■ 42-108	Seal	1
4	■ 41-113	Cone	1
5	●■ 41-209	Cup	1
6	● 1918-14-0A	Repair Hub Assembly (Includes ● Items)	1
7	● 65-122	1/4 x 65° Zerk	2
8	● 62-295	Wheel Bolt	6
9	●■ 41-208	Cup	1
10	■ 41-112	Cone	1
11	64-120	1" SAE Flat Washer	1
12	63-204	1NF Slotted Hex Nut	1
13	60-702	3/16"DIA. x 1-1/2" Cotter Pin	1
14	52-302	Hub cap	1
15	62-205	3/4NC x 5" GD5 Cap Screw	4
16	64-112	3/4" STD. Lock Washer	4
17	63-112	3/4NC Hex Nut	4
	1918-84-0	Hub Bearing Repair Kit (Includes ■ Items)	

GAUGE WHEEL ASSEMBLY

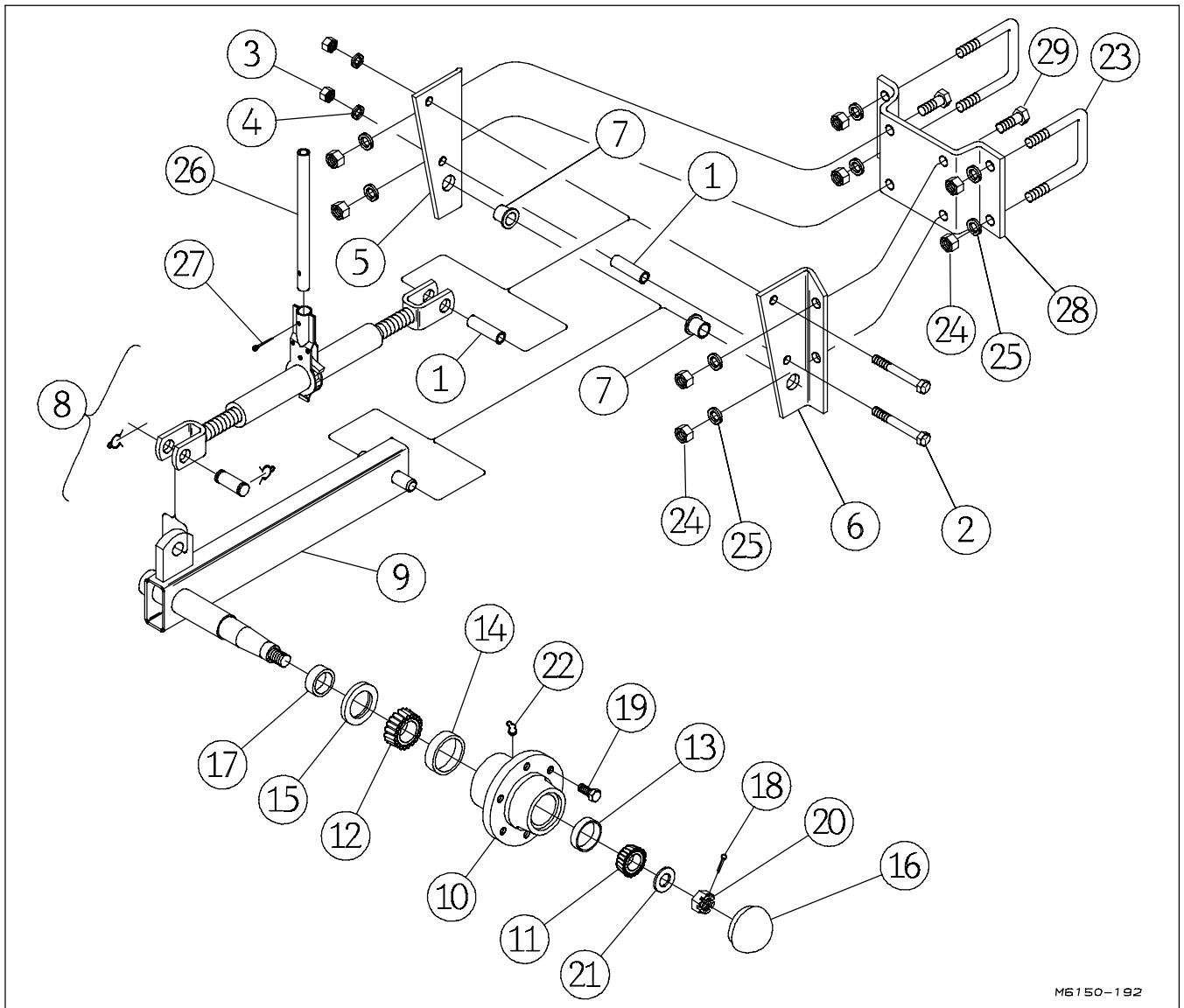

ME150-192

Item	Part Number	Part Description	Qty	Item	Part Number	Part Description	Qty
	4000-49-0	Lt. Gauge Wheel Assm. - Shown		16	52-302	Hub Cap	1
	4000-50-0	Rt. Gauge Wheel Assm.		17	53-105	Wear Sleeve	1
1	4000-50-1	Spacer Tube	2	18	60-702	3/16" x 1-1/2" Cotter Pin	1
2	62-339	5/8NC x 4-1/2"GD5 Bolt	2	19	★ 62-295	Wheel Bolt	6
3	63-109	5/8NC Hex Nut	2	20	63-204	1NF Slotted Nut	1
4	64-109	5/8" STD. Lock Washer	2	21	64-120	1"SAE Black Washer	1
5	4000-51-0	Left Side Plate Assembly	1	22	★ 65-122	1/4 x 65° Drive Zerk	2
6	4000-52-0	Right Side Plate Assembly	1	23	61-149	3/4"DIA. U-Bolt	2
7	4000-51-3	Flanged Wear Sleeve	2	24	63-112	3/4NC Hex Nut	8
8	4000-48-0	Ratchet Jack	1	25	64-112	3/4" STD. Lock Washer	8
9	4000-215-0	Lt. Repair Hub Assembly	1	26	4000-50-2	6-1/2" Jack Handle	1
	4000-216-0	Rt. Repair Hub Assembly	1	27	60-708	1/4"DIA. x 1-3/4" Cotter Pin	1
10	★ 1918-14-0A	Repair Hub Assembly	1	28	6150-95-1	Gauge Wheel Mount Plate	1
11	● 41-112	Front Cone	1	29	62-421	3/4NC x 2" GD5 Cap Screw	4
12	● 41-113	Rear Cone	1	30	1000-95588-0	Wheel & Tire Assembly - Not shown See page P38 for parts	Spec
13	★● 41-208	Front Cup	1	1918 -84-0 Hub Bearing Repair Kit (Includes ● Items)			
14	★● 41-209	Rear Cup	1	1918 -14-0A Repair Hub Assembly (Includes ★ Items)			
15	● 42-108	Seal	1				

WHEELS & TIRES

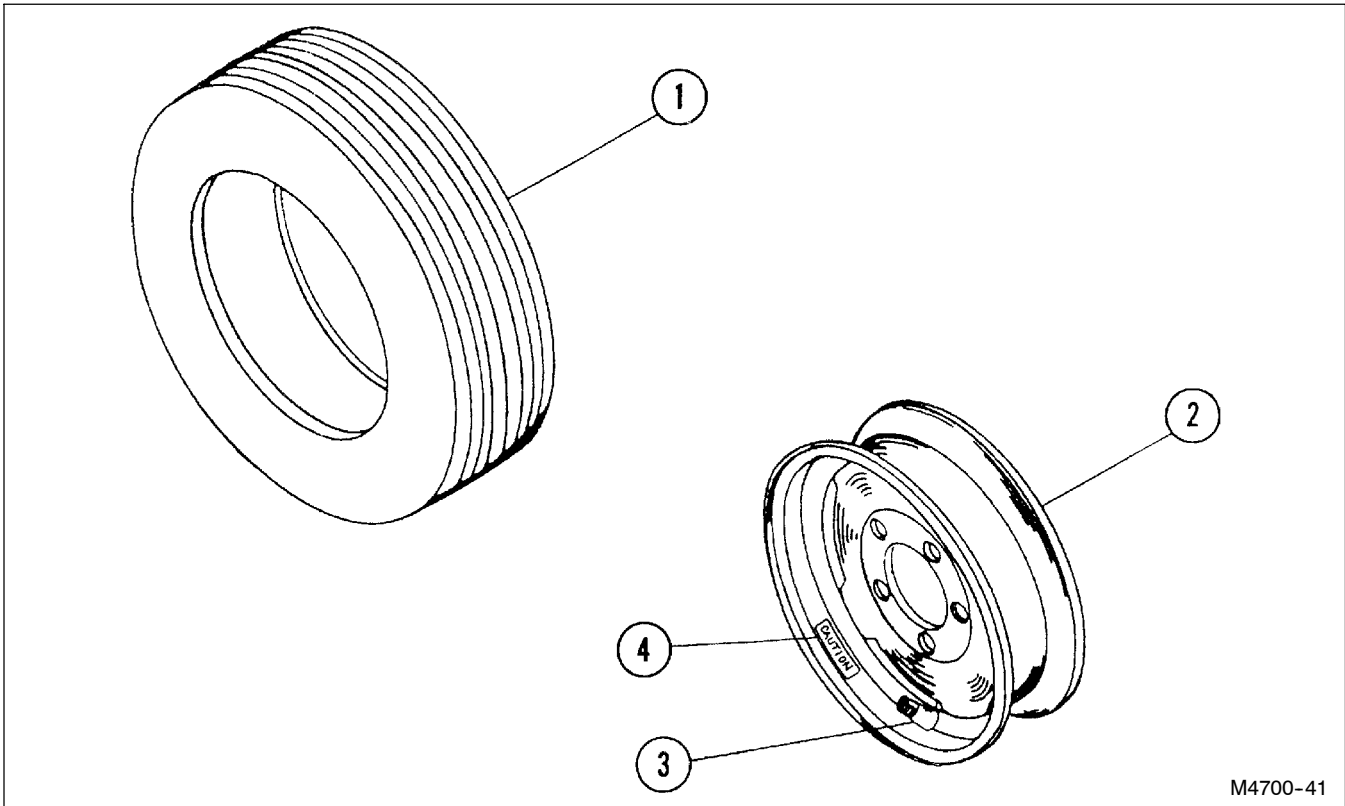

FOR MODELS - ALL

9/02

Item	Part Number	Part Description	Qty.
	1000-11580-0	Wheel Assembly	1
1	51-106	Tire 11L x 15, 8-Ply	1
2	52-103	Wheel 15" x 10" - 6 Bolt	1
3	51-107	Valve Stem	1
4	74-109	Decal - CAUTION Check Wheel Bolts	1
	1000-95588-0	Wheel Assembly	1
1	51-102	Tire 9.5L x 15, 8-Ply	1
2	52-102	Wheel 15" x 8", 6 Bolt	1
3	51-107	Valve Stem	1
4	74-109	Decal - CAUTION Check Wheel Bolts	1
	1000-12540-01	Wheel Assembly	
1	51-114	Tire 12.5L x 15 FI Load Ranger "F" Tire	1
2	52-114	Wheel 15" x 10", 8 Bolt	1
3	51-107	Valve Stem	1
4	74-109	Decal - CAUTION Check Wheel Bolts	1

TIE RODS

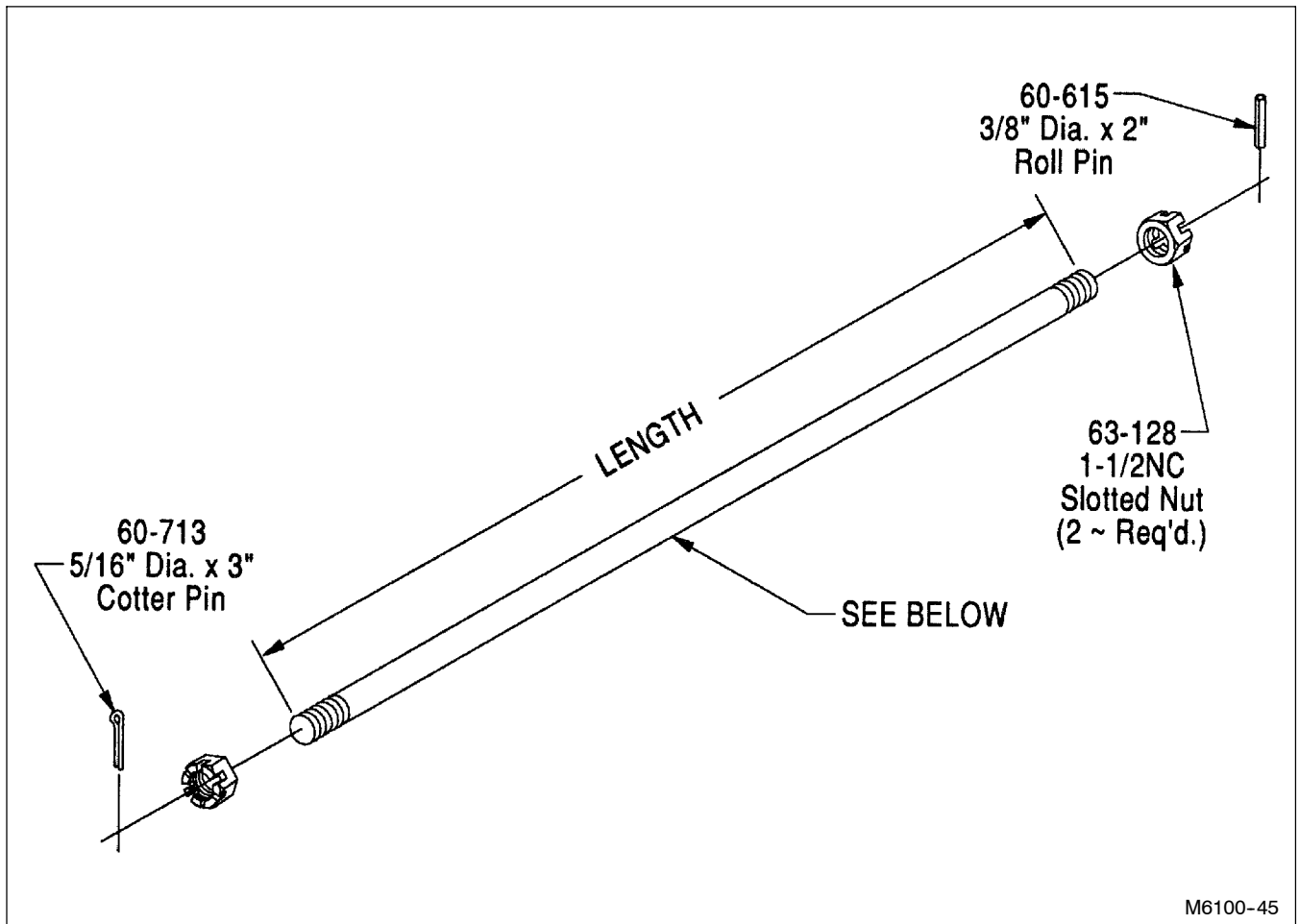

M6100-45

FOR MODELS - ALL

9/03

Model	Location	Length	Number Of Disc	Tie Rod Number
TL 6200 - 09	Left & Right Center	51-3/4"	6	2146-82-1
TL 6200 - 12	Left & Right Center	70-3/8"	8	2212-18-1
TL 6200 - 15	Left & Right Center	88-1/4"	10	2225-18-1
TL 6200 - 18	Left & Right Center	51-3/4"	6	2146-82-1
	Left & Right Wing	51-3/4"	6	2146-82-1
TL 6200 - 21	Left & Right Center	51-3/4"	6	2146-82-1
	Left & Right Wing	60-7/8"	7	2136-82-1
TL 6200 - 24	Left & Right Center	51-3/4"	6	2146-82-1
	Left & Right Wing	88-1/4"	10	2225-18-1
TL 6200 - 27	Left & Right Center	70-3/8"	8	2212-18-1
	Left & Right Wing	88-1/4"	10	2225-18-1
TL 6200 - 31	Left & Right Center	70-3/8"	8	2212-18-1
	Left & Right Inside Wing	51-3/4"	6	2146-82-1
	Left & Right Outside Wing	51-3/4"	6	2146-82-1
TL 6200 - 36	Left & Right Center	70-3/8"	8	2212-18-1
	Left & Right Inside Wing	70-3/8"	8	2212-18-1
	Left & Right Outside Wing	60-7/8"	7	2136-82-1
TL 6200 - 42	Left & Right Center	70-3/8"	8	2212-18-1
	Left & Right Inside Wing	97-3/8"	11	2227-18-1
	Left & Right Outside Wing	79-1/8"	9	2224-18-1
TL 6200 - 45	Left & Right Center	70-3/8"	8	2212-18-1
	Left & Right Inside Wing	97-3/8"	11	2227-18-1
	Left & Right Outside Wing	88-1/4"	10	2225-18-1

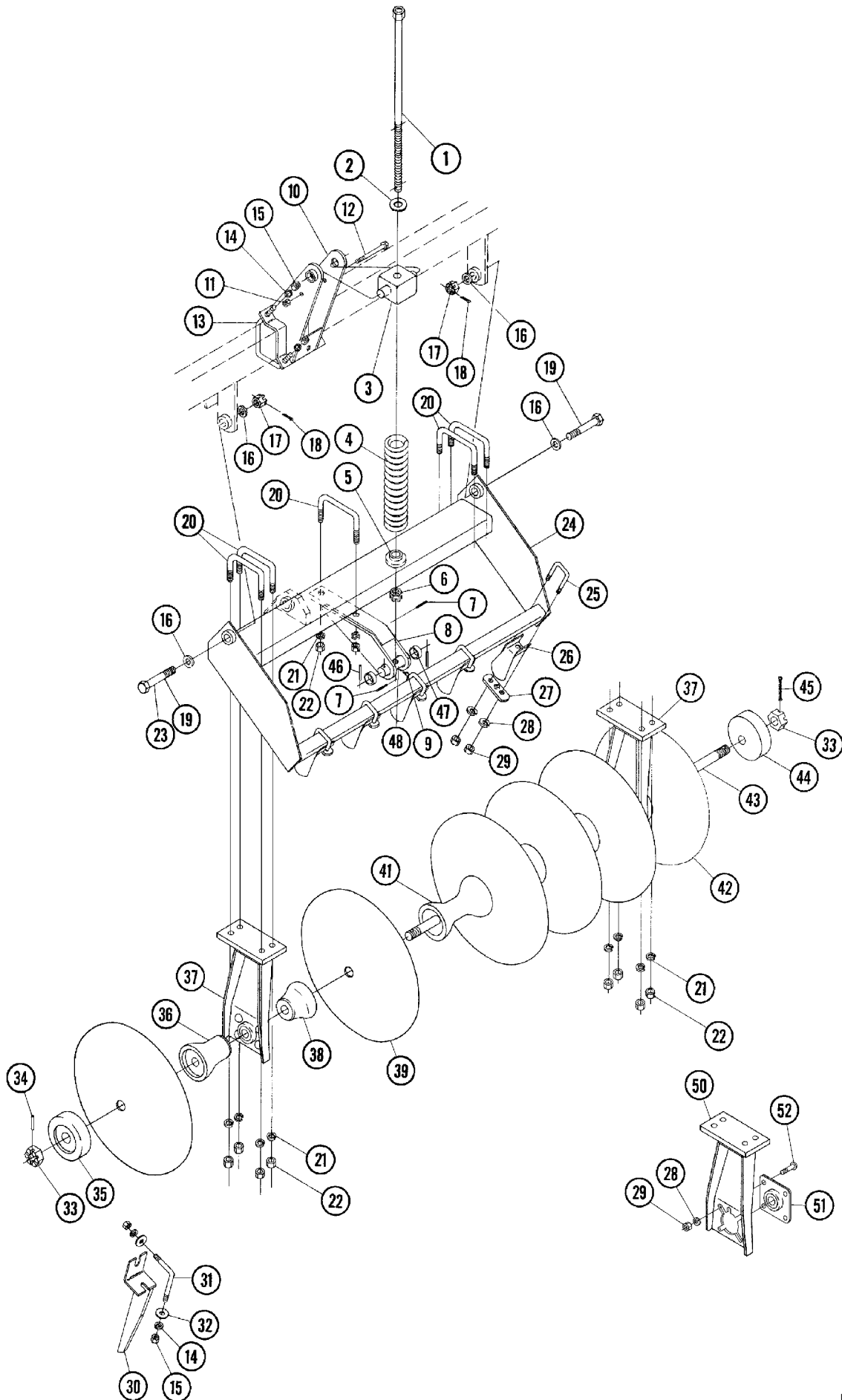

DISC GANG ASSEMBLY

FOR MODELS - ALL

9/07

Item	Part Number	Part Description	Qty.	Item	Part Number	Part Description	Qty.
	6127-90-0A	Spring Support Assembly	1-12	25	61-115	1/2" DIA. U-Bolt	
1	6127-96-0	Adjustment Screw Weldment	1	26	32-101	R.H. Scraper Blade	
2	64-155	1" SAE Flat Washer	1		32-103	L.H. Scraper Blade	
3	3127-30-1	Trunnion	1	27	1483-286-1	Clamp	
4	76-132	Compression Spring	1	28	64-107	1/2" STD. Lock Washer	
5	6127-90-1	Spring Washer Casting	1	29	63-106	1/2NC Hex Nut	
6	63-120	1NC Slotted Hex Nut	1	30	3131-157-0	Right Trash Bar	
7	60-626	3/16" DIA. x 1-1/2" Roll Pin	2		3131-158-0	Left Trash Bar	
8	6127-94-0A	Arm Weldment	1	31	950-20-4	"L" Bolt	
9	65-101	1/8NPT STD. Zerk	1	32	64-110	5/8" STD. Flat washer	
10	6127-93-0	Spring Support Weldment	1	33	63-128	1-1/2NC Slotted Hex Nut	
11	63-134	3/8NC Lock Nut	1	34	60-615	3/8" DIA. x 2" Roll Pin	
12	62-562	3/8NC x 4-1/2" GD. 5 Bolt	1	35	3950-0-5	End Washer	
13	61-228	5/8" DIA. U-Bolt		36	364-0-9	Long Half Spool	
14	64-109	5/8" STD. Lock Washer		37	1918-10-0	Bearing Arm Assembly	
15	63-109	5/8NC Hex Nut		38	1280-0-10	Short Half Spool	
16	64-141	Hardened Flat Washer		39	30-208	20" Disc Blade (Standard)	
17	63-120	1NC Slotted Nut		40			
18	60-703	3/16" DIA. x 1-3/4" Cotter Pin		41	364-0-7	Spacer Spool	
19	62-318	1NC x 4-1/2" Pivot Bolt		42	30-104	18" Disc Blade	
20	61-143	3/4" DIA. U-Bolt		43	See page P33	Tie Rod	
21	64-112	3/4" STD. Lock Washer		44	2212-18-2	End Washer	
22	63-112	3/4NC Hex Nut		45	60-713	5/16" DIA. x 3" Cotter Pin	
23	3131-84-1	Pivot Bolt (Model 6171 ONLY)		46	60-608	1/4" DIA. x 2-1/2" Roll Pin	2
24	6110-46-0	Gang Beam 52-1/2"		47	53-142	Wear Sleeve, 2od x 1.77id x .50	2
	6112-46-0	Right Gang Beam 68"		48	6127-90-2	Trunnion	1
	6112-47-0	Left Gang Beam 68"		49			
	6115-52-0	Gang Beam 86"		50	1963-9-0	Bearing Arm Weldment	1
	6115-53-0	Gang Beam 86"		51	40-109	Bearing Assembly	1
	3118-46-0	Center Gang Beam		52	62-474	1/2NC x 1-1/2"GD5 Carriage Bolt	4
	6118-52-0	Gang Beam 51"					
	6118-53-0	Gang Beam 51"					
	6121-48-0	Gang Beam 56"					
	6121-49-0	Gang Beam 56"					
	6127-70-0	Gang Beam 85-1/2"					
	3112-46-0	Right Gang Beam 68"					
	3112-47-0	Left Gang Beam 68"					
	6131-46-0	Gang Beam 52"					
	6131-47-0	Gang Beam 52"					
	6131-48-0	Gang Beam 50-7/8"					
	6142-50-0	Gang Beam 83"					
	6142-52-0	Gang Beam 83"					
	6345-70-0	Gang Beam 94-1/2"					
	6345-80-0	Gang Beam 83"					
	6345-81-0	Gang Beam 83"					
	6210-80-0	Gang Beam 92-11/16"					
	6210-81-0	Gang Beam 92-11/16"					

See page P74 for Hydraulic Disc Gang Option

2 PIECE K-TINE SHANK ASSEMBLY - STANDARD MOUNT

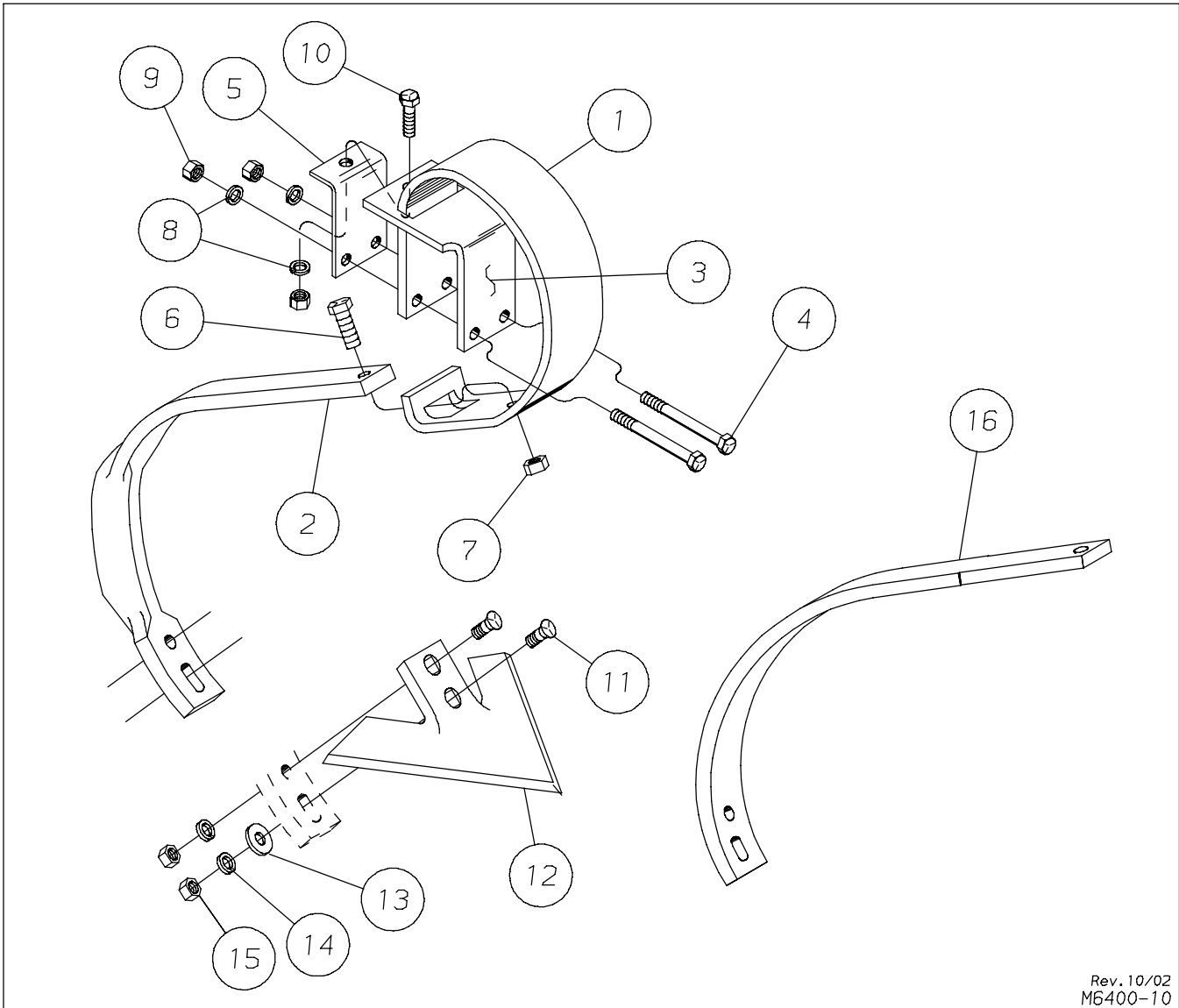

FOR MODELS - ALL

10/02

Item	Part Number	Part Description	Qty.
1	31-179	Shank Mount	1
2	31-180	Shank	1
3	6127-0-14A	Shank Mount Clamp	1
4	62-458	1/2NC x 5" GD5 Cap Screw	2
5	6127-0-15	Clamp	1
6	62-707	5/8NC x 2" GD8 Cap Screw	1
7	63-110	5/8NC Lock Nut	1
8	64-107	1/2" STD. Lock Washer	3
9	63-106	1/2NC Hex Nut	3
10	62-569	1/2NC x 1-1/2" GD5 Cap Screw	1
11	62-317	7/16NC x 1-1/2" GD5 #3 Plow Bolt	2
12	33-198	Sweep - 9" 47° Stem Angle	1
	33-199	Sweep - 10" 47° Stem Angle	1
13	64-106	7/16" STD. Flat Washer	1
14	64-105	7/16" STD. Lock Washer	2
15	63-104	7/16NC Hex Nut	2
16	31-204	Flat Cultivator Shank (Optional)	1

2 PIECE K-TINE SHANK ASSEMBLY - EXTENDED MOUNT

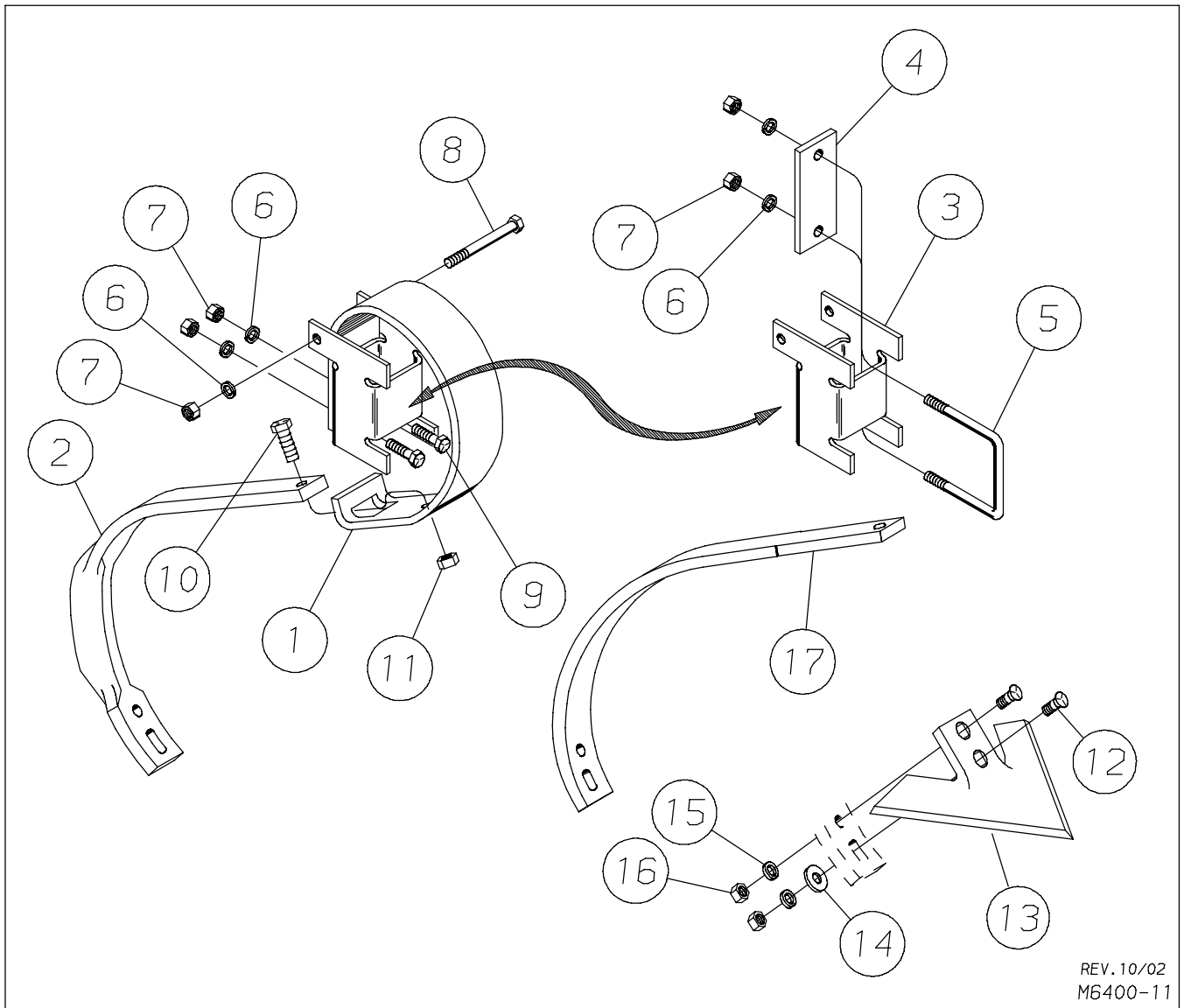

REV. 10/02
M6400-11

FOR MODELS - ALL

10/02

Item	Part Number	Part Description	Qty.
1	31-179	Shank Mount	1
2	31-180	Shank	1
3	4226-0-10	Extended Bracket	1
4	4226-0-11	Bolt Plate	1
5	61-216	1/2" DIA. U-Bolt (4-1/4" Leg)	1
6	64-107	1/2" STD. Lock Washer	5
7	63-106	1/2NC Hex Nut	5
8	62-351	1/2NC x 4-1/2" GD5 Cap Screw	1
9	62-569	1/2NC x 1-1/2" GD5 Cap Screw	2
10	62-707	5/8NC x 2" GD8 Cap Screw	1
11	63-110	5/8NC Lock Nut	1
12	62-317	7/16NC x 1-1/2" GD5 #3 Plow Bolt	2
13	33-198	Sweep - 9" 47° Stem Angle	1
13	33-199	Sweep - 10" 47° Stem Angle	1
14	64-106	7/16" STD. Flat Washer	1
15	64-105	7/16" STD. Lock Washer	2
16	63-104	7/16NC Hex Nut	2
17	31-204	Flat Cultivator Shank - Optional	1

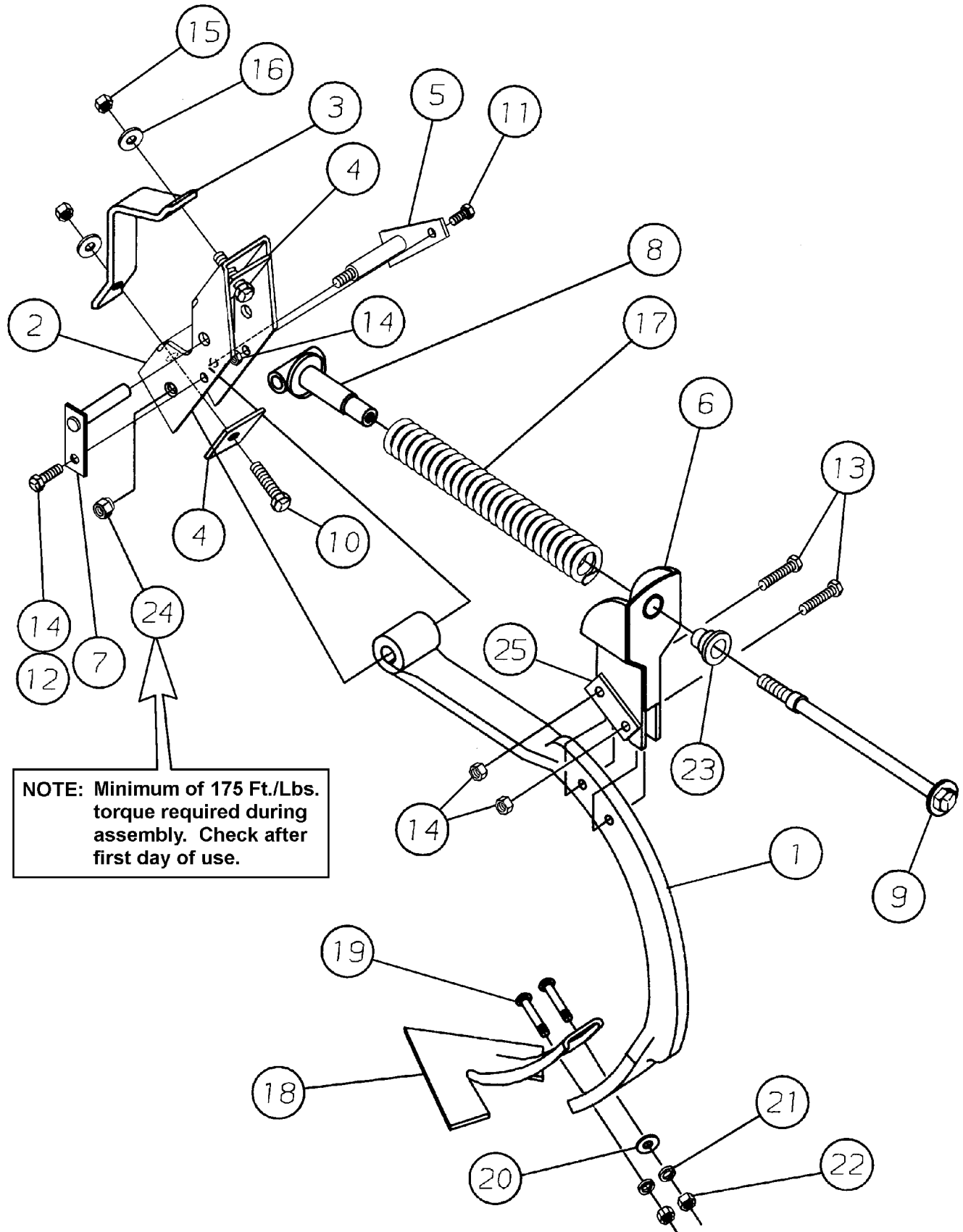

NOTE: Minimum of 175 Ft./Lbs. torque required during assembly. Check after first day of use.

XT270 SHANK ASSEMBLY

FOR MODELS - ALL

9/03

<i>Item</i>	<i>Part Number</i>	<i>Part Description</i>	<i>Qty.</i>
	6150-25-0A	26" XT Shank Assembly	1
1	31-182	3/4" x 2" Cultivator Shank	1
2	6150-35-0	Channel Repair Assembly (Includes Items 2, 5, 11, 24)	1
3	6150-25-2	Mounting Strap	1
4	6150-25-3	Doubler	2
5	6150-34-0	Stud Weldment	1
6	6150-26-0	Spring Mount Weldment (Includes Item #23)	1
7	6150-30-0	Pin Weldment	1
8	6150-31-0A	Spring End Weldment	1
9	6150-32-0A	Tension Bolt Weldment	1
10	62-169	5/8NC x 2" GD. 5 Cap Screw	2
11	62-420	5/8NC x 1-1/4" GD5 Cap Screw	1
12	62-300	1/2NC x 1" GD. 5 Cap Screw	1
13	62-725	1/2NC x 2-1/2" GD.8 Cap Screw	2
14	63-107	1/2NC Lock Nut	4
15	63-110	5/8NC Lock Nut	2
16	64-110	5/8" STD. Flat Washer	2
17	76-207	Spring - Compression	1
18	★ 33-200	12" Sweep 47° 1/4" Thick	1
	★ 33-189	9" Sweep 47° 1/4" Thick	1
	★ 33-190	10" Sweep 47° 1/4" Thick	1
19	★ 62-664	7/16NC x 2" GD. 5 #3 Plow Bolt	2
20	★ 64-106	7/16" STD. Flat Washer	1
21	★ 64-105	7/16" STD. Lock Washer	2
22	★ 63-104	7/16NC Hex Nut	2
23	★ 53-165	Flanged Sleeve	11
24	63-208	5/8NF Wheel Nut	1
25	6150-25-5	Doubler	2
★ Not part of Shank Assembly			

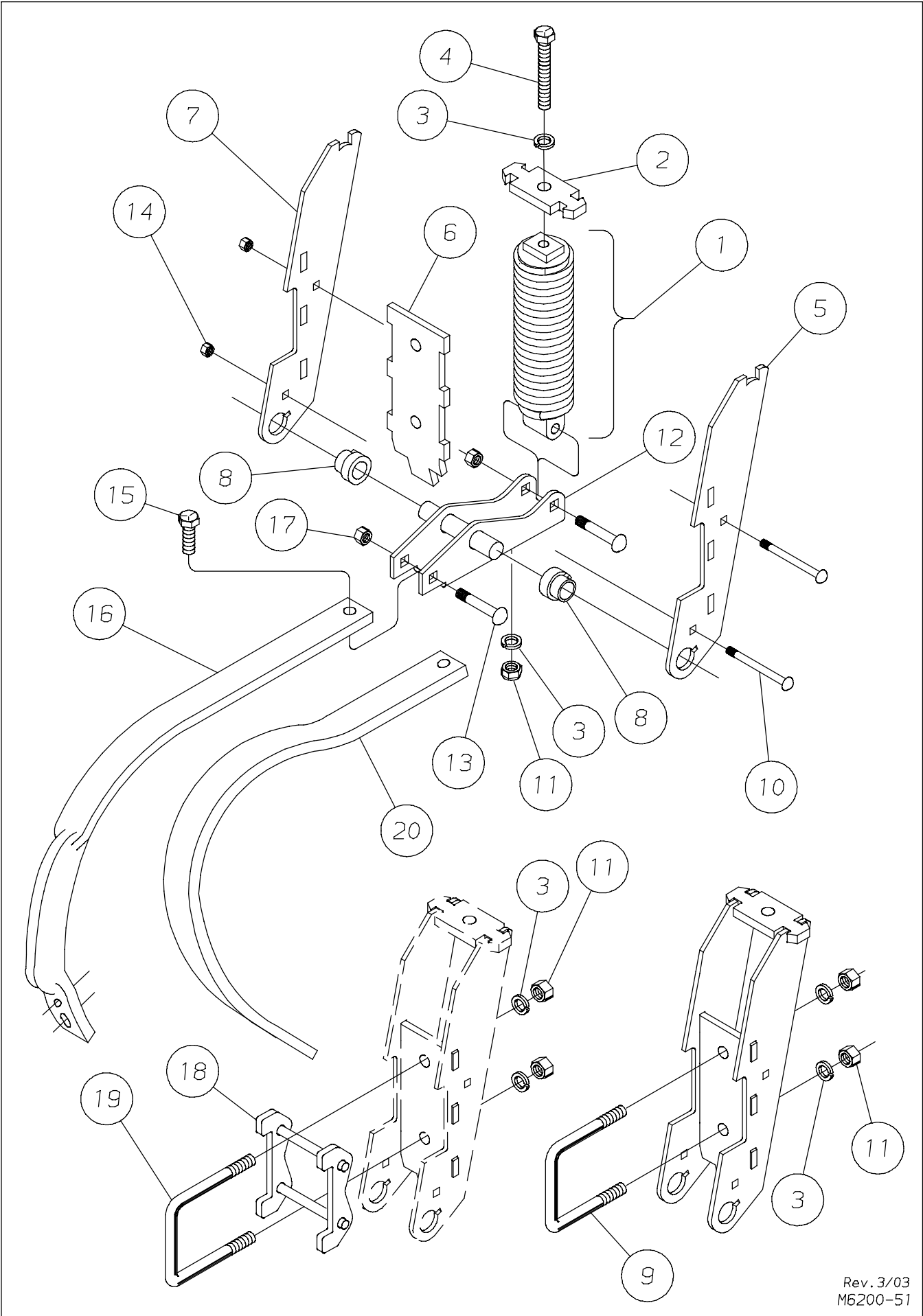

Rev. 3/03
M6200-51

SPRING SHANK ASSEMBLY

FOR MODELS - ALL

9/03

<i>Item</i>	<i>Part Number</i>	<i>Part Description</i>	<i>Qty,</i>
1	5630-124-0	Extension Spring Assembly	1
2	5630-125-2	Spring Plate	1
3	64-109	5/8" STD. Lock Washer	6
4	62-387	5/8NC x 4" GD5 Full Thread Bolt	1
5	5630-122-0A	Right Side Plate Assembly (Includes (1) Item 8)	1
6	5630-125-1	Clamp Plate	1
7	5630-121-0A	Left Side Plate Assembly (Includes (1) Item 8)	1
8	53-169	Flanged Wear Sleeve - Keyed, 1.25"od x 1.00"id	2
9	61-155	U-Bolt 5/8"DIA. x 4-1/16"W x 4-5/8"L	1
10	62-797	3/8NC x 4-1/4" GD5 Carriage Bolt	2
11	63-109	5/8NC Hex Nut	5
12	5630-123-0	Shank Pivot Weldment	1
13	62-798	1/2NC x 3" GD5 Special Carriage Bolt	2
14	63-103	3/8NC Lock Nut	2
15	62-167	5/8NC x 1-3/4" GD5 Cap Screw	1
16	31-199	5/8" x 1-3/4" Cultivator Shank	1
17	63-107	1/2NC Lock Nut	2
18	5630-129-0	Adapter Weldment	1
19	61-123	U-Bolt 5/8" DIA. x 4-1/16" W x 5-3/8" L	1
20	31-205	Flat Cultivator Shank - Optional	1

WING LIFT GROUP

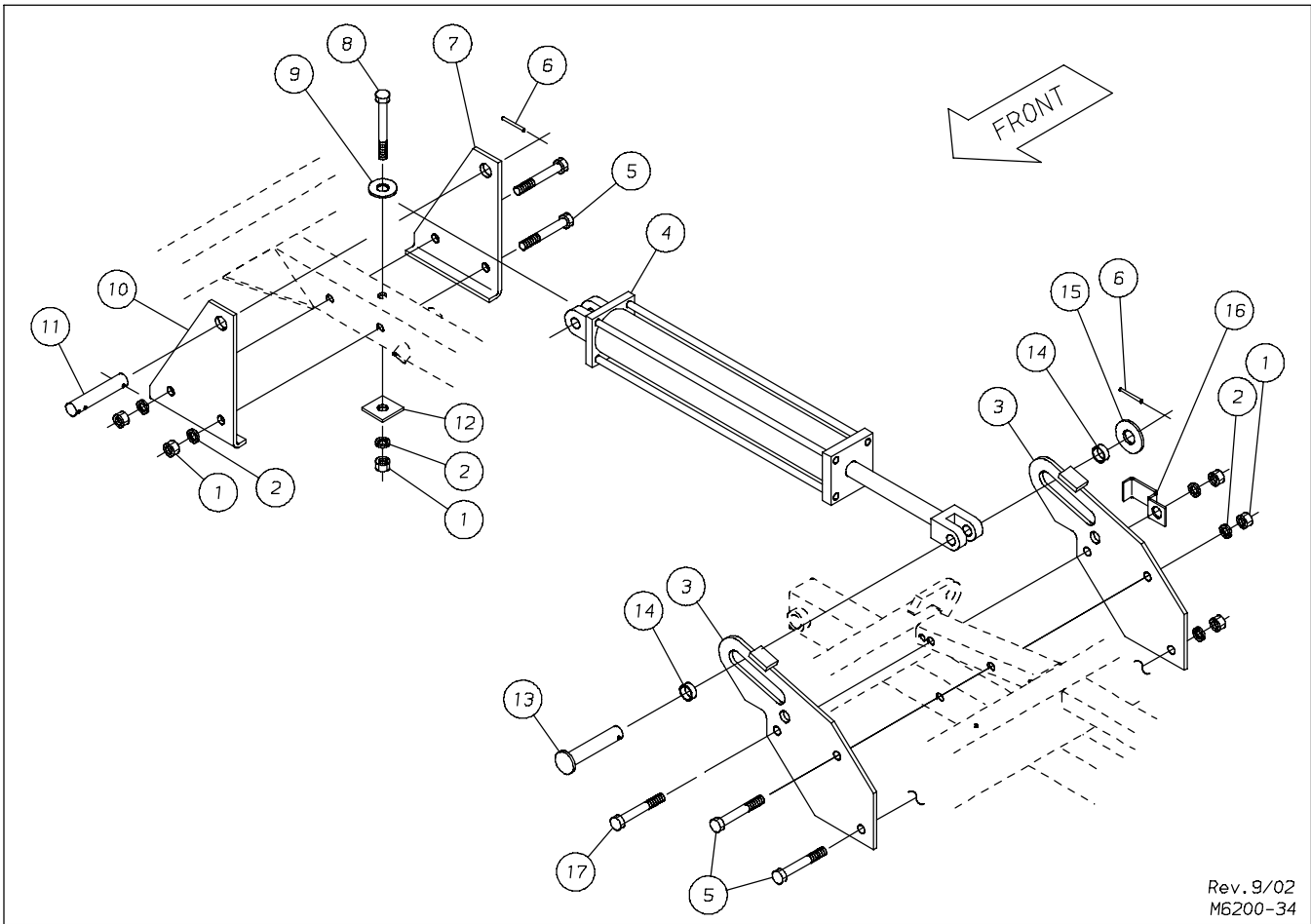

Rev. 9/02
M6200-34

FOR MODELS - TL 6200 18 - 21

9/02

Item	Part Number	Part Description	Qty.
1	63-112	3/4NC Hex Nut	6
2	64-112	3/4" STD. Lock Washer	6
3	6118-47-0	Side Plate Weldment	2
4	21-181	4" x 24" Prince Cylinder Assembly	1
5	62-205	3/4NC x 5" GD. 5 Cap Screw	5
6	60-606	1/4"DIA. x 2" Roll Pin	2
7	6127-0-5	Left Cylinder Lug	1
8	62-210	3/4NC x 6" GD. 5 Cap Screw	1
9	64-113	3/4" STD. Flat Washer	1
10	6127-0-4	Right Cylinder Lug	1
11	6327-0-3	Wing Lift Pin	1
12	3755-12-2	Flat	1
13	3131-77-0	Cylinder Clevis Pin	1
14	53-109	Wear Sleeve	2
15	64-126	1-1/4" STD. Flat Washer	1
16	3127-83-1	Hose Clamp	1
17	62-207	3/4NC x 5-1/2" GD. 5 Cap Screw	1

WING LIFT GROUP

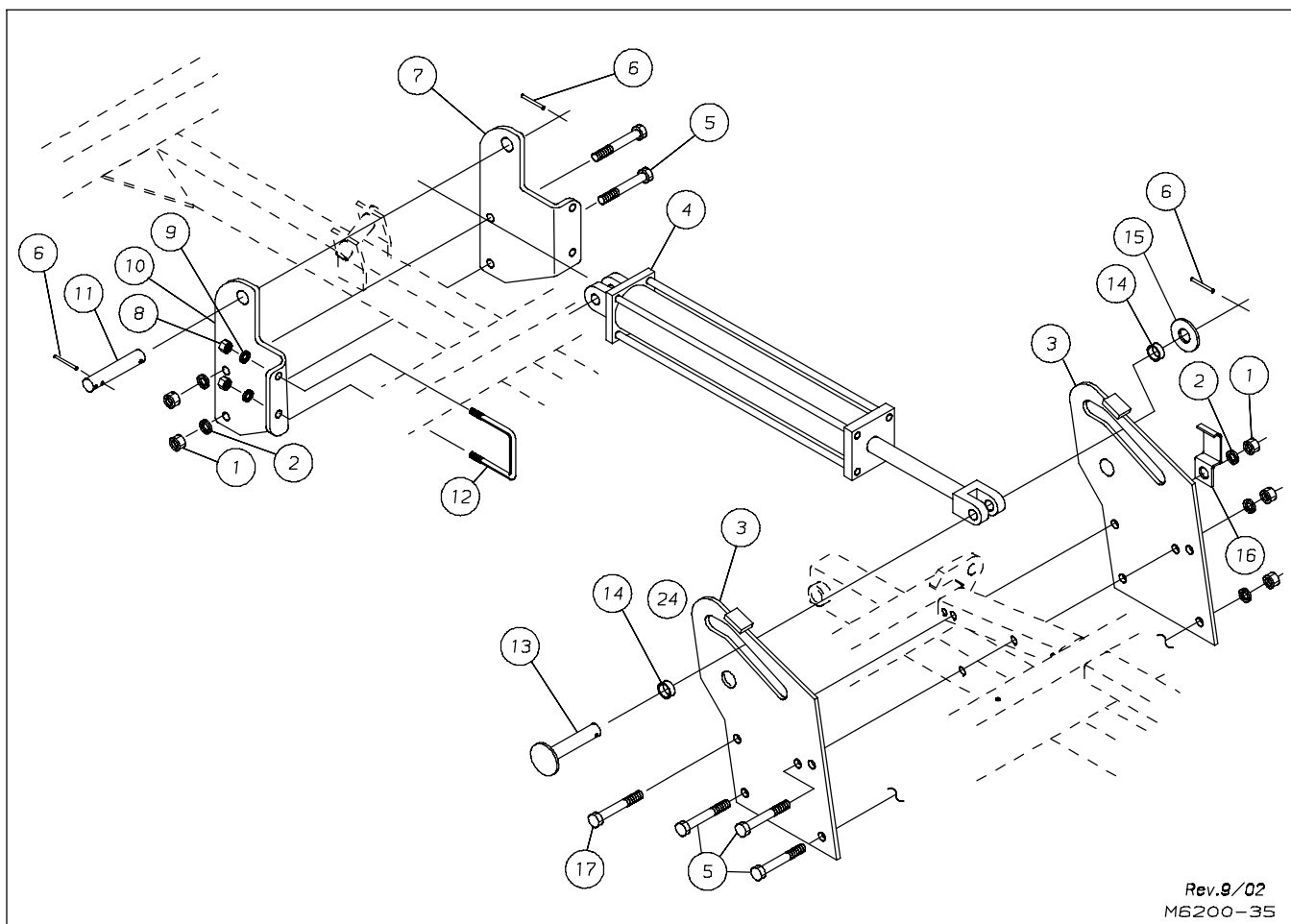

Rev.9/02
M6200-35

FOR MODELS - TL 6200 24, 27, 31

9/03

Item	Part Number	Part Description	Qty.
1	63-112	3/4NC Hex Nut	7
2	64-112	3/4" STD. Lock Washer	7
3	6124-43-0	Side Plate Weldment	2
4	21-182	4" x 32" Prince Cylinder Assembly	1
5	62-205	3/4NC x 5" GD. 5 Cap Screw	5
6	60-606	1/4"DIA. x 2" Roll Pin	2
7	6327-0-5	Left Cylinder Lug	1
8	63-109	5/8NC Hex Nut	4
9	64-109	5/8" STD. Lock Washer	4
10	6327-0-4	Right Cylinder Lug	1
11	6327-0-3	Wing Lift Pin	2
12	61-126	5/8" DIA. U-Bolt (4-3/8" Leg)	2
13	3131-77-0	Cylinder Clevis Pin	1
14	53-109	Wear Sleeve	2
15	64-126	1-1/4" STD. Flat Washer	1
16	3127-83-1	Hose Clamp	1
17	62-207	3/4NC x 5-1/2" GD. 5 Cap Screw	1

INSIDE WING LIFT

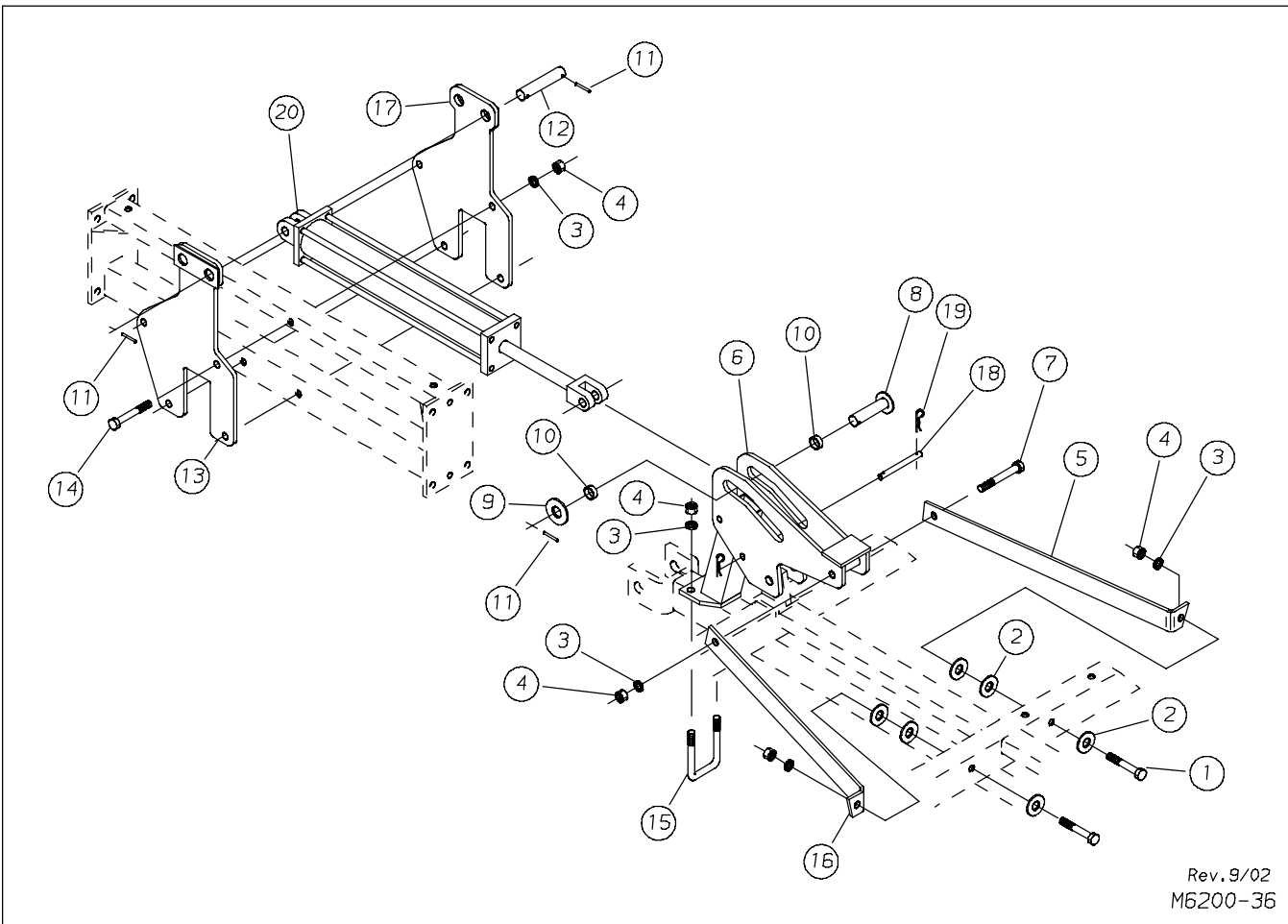

FOR MODELS - TL 6200 36

9/02

Item	Part Number	Part Description	Qty.
1	62-203	3/4NC x 4-1/2" GD. 5 Cap Screw	2
2	64-113	3/4" STD. Flat Washer	2
3	64-112	3/4" STD. Lock Washer	14
4	63-112	3/4NC Hex Nut	14
5	6337-0-4	Right Fold Strap	1
6	6337-50-0A	Wing Lift Bracket Weldment	1
7	62-210	3/4NC x 6" GD. 5 Cap Screw	1
8	3131-77-0	Cylinder Clevis Pin	1
9	64-126	1-1/4" STD. Flat Washer	1
10	53-109	Wear Sleeve	2
11	60-606	1/4" DIA. x 2" Roll Pin	3
12	3755-0-16	Cylinder Pin	1
13	6345-88-0	Right Fold Plate Weldment	1
14	62-205	3/4NC x 5" GD. 5 Cap Screw	4
15	61-232	3/4"DIA. U-Bolt	1
16	6337-0-3	Left Fold Strap	1
17	6345-89-0	Fold Plate Weldment	2
18	6345-0-4	Wing Lock Pin	1
19	60-716	#3 Hair Pin Cotter	2
20	21-189	5" x 32" Hydraulic Cylinder	1

OUTSIDE WING LIFT

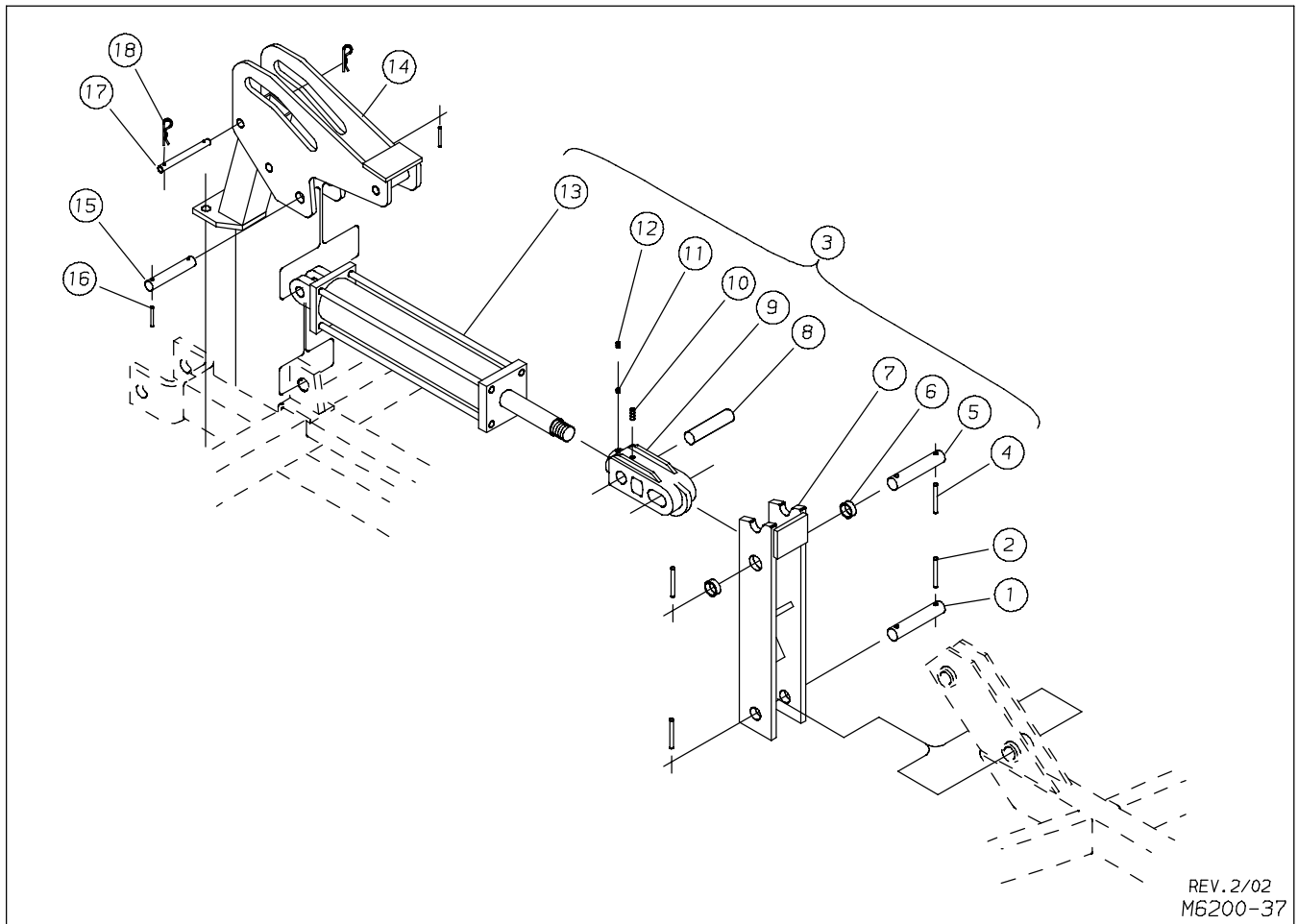

REV. 2/02
M6200-37

FOR MODELS - TL 6200 36

9/03

Item	Part Number	Part Description	Qty.
1	4260-80-3	Pin	2
2	60-618	3/8" DIA. x 3" Roll Pin	2
3	6136-80-0	Wing Lift Cylinder Assembly	1
4	60-618	3/8" DIA. x 3" Roll Pin	2
5	4260-80-3	Pin	1
6	53-109	Wear Sleeve	2
7	6136-70-0	Wing Lift Arm Weldment	1
8	4260-81-1	1-1/4" DIA. x 5" Pin	1
9	4260-80-1	Cylinder Rod End	1
10	60-608	1/4" DIA. x 2-1/2" Roll Pin	1
11	21-407	Nylon Bushing	1
12	62-324	3/8NC x 3/8" Socket Head Cup Point Set Screw	1
13	21-185	4" x 30" Prince Hydraulic Cylinder Assembly	1
14	6337-50-0A	Wing Lift Bracket Weldment	1
15	960-35-2	Pin	1
16	60-606	1/4" DIA. x 2" Roll Pin	2
17	6345-0-4	Wing Lock Pin	1
18	60-716	#3 Hair Pin Cotter	2

INSIDE WING LIFT

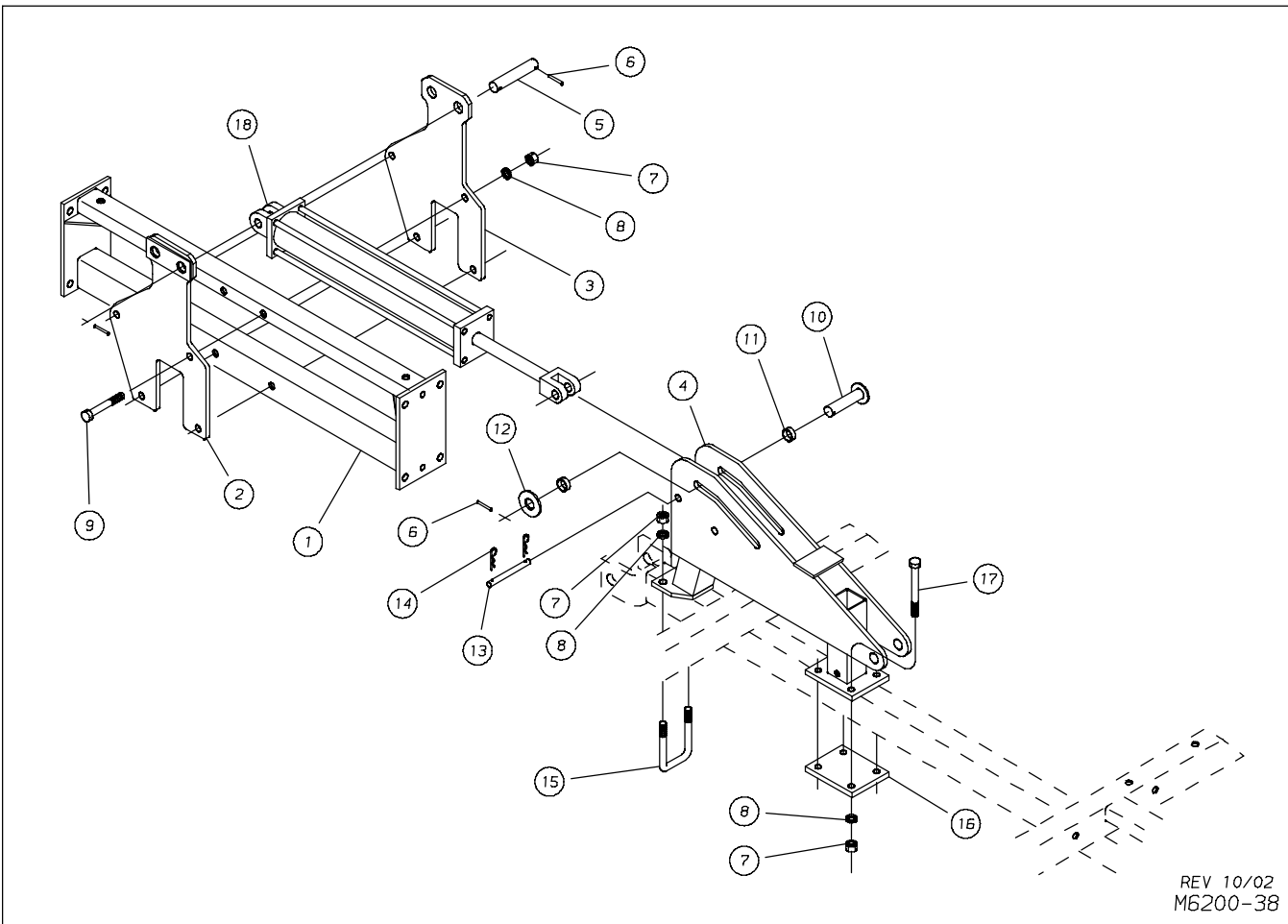

REV 10/02
M6200-38

FOR MODELS - TL 6200 42 & 45

9/03

Item	Part Number	Part Description	Qty.
1	6127-42-0A	Frame Connector Weldment	1
2	6345-88-0	Right Fold Plate Weldment	1
3	6345-89-0	Left Fold Plate Weldment	1
4	6345-56-0	Wing Lift Bracket Weldment	1
5	3755-0-16	Cylinder Pin	1
6	60-606	1/4" DIA. x 2" Roll Pin	3
7	63-112	3/4NC Hex Nut	10
8	64-112	3/4" STD. Lock Washer	10
9	62-205	3/4NC x 5" GD5 Cap Screw	4
10	3131-77-0	Cylinder Clevis Pin	1
11	53-109	Wear Sleeve	2
12	64-126	1-1/4" STD. Flat Washer	1
13	6345-0-4	Wing Lock Pin	1
14	60-716	#3 Hair Pin Cotter	2
15	61-232	U-Bolt 3/4" DIA.	1
16	6136-50-5	Bolt Plate	1
17	62-213	3/4NC x 6-1/2" GD5 Cap Screw	4
18	21-189	5" x 32" Prince Hydraulic Cylinder Assembly	1

OUTSIDE WING LIFT

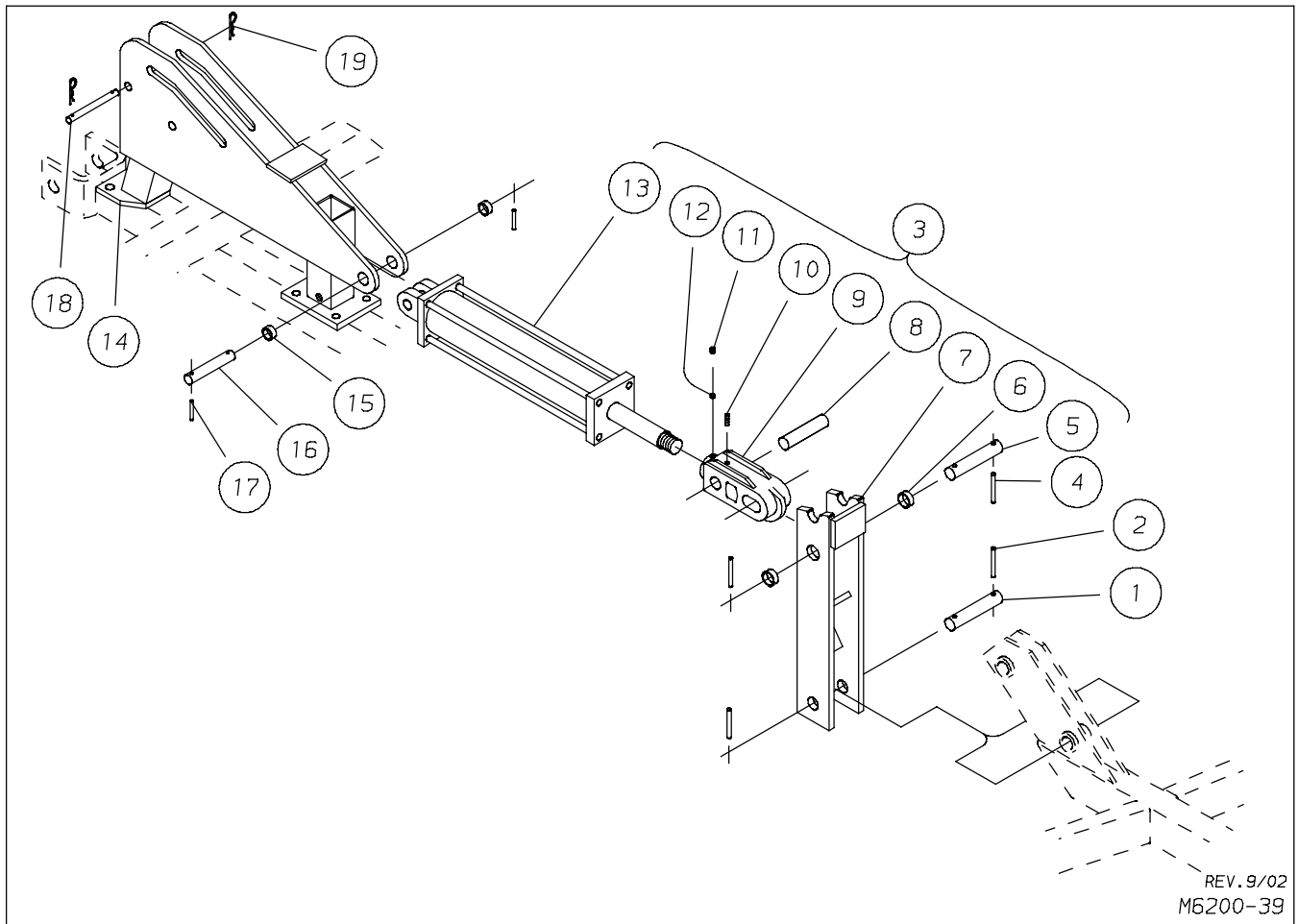

REV. 9/02
M6200-39

FOR MODELS - TL 6200 42 & 45

9/03

Item	Part Number	Part Description	Qty.
1	4260-80-3	Pin	2
2	60-618	3/8"DIA. x 3" Roll Pin	2
3	6345-86-0	Wing Lift Cylinder Assembly	1
4	60-618	3/8"DIA. x 3" Roll Pin	2
5	4260-80-3	Pin	1
6	53-109	Wear Sleeve	2
7	6136-70-0	Wing Lift Arm Weldment	1
8	4260-81-1	1-1/4" DIA. x 5" Pin	1
9	4260-80-1	Cylinder Rod End	1
10	60-608	1/4" DIA. x 2-1/2" Roll Pin	1
11	62-324	3/8NC x 3/8" Socket Head Cup Point Set Screw	1
12	21-407	Nylon Bushing	1
13	21-1027	4-1/2" x 32" Prince Hydraulic Cylinder Assembly	1
14	6345-56-0	Wing Lift Bracket Weldment	1
15	53-116	Wear Sleeve	2
16	6327-0-3	Pin	1
17	60-606	1/4"DIA. x 2" Roll Pin	2
18	6345-0-4	Wing Lock Pin	1
19	60-716	#3 Hair Pin Cotter	2

DEPTH VALVE ASSEMBLY

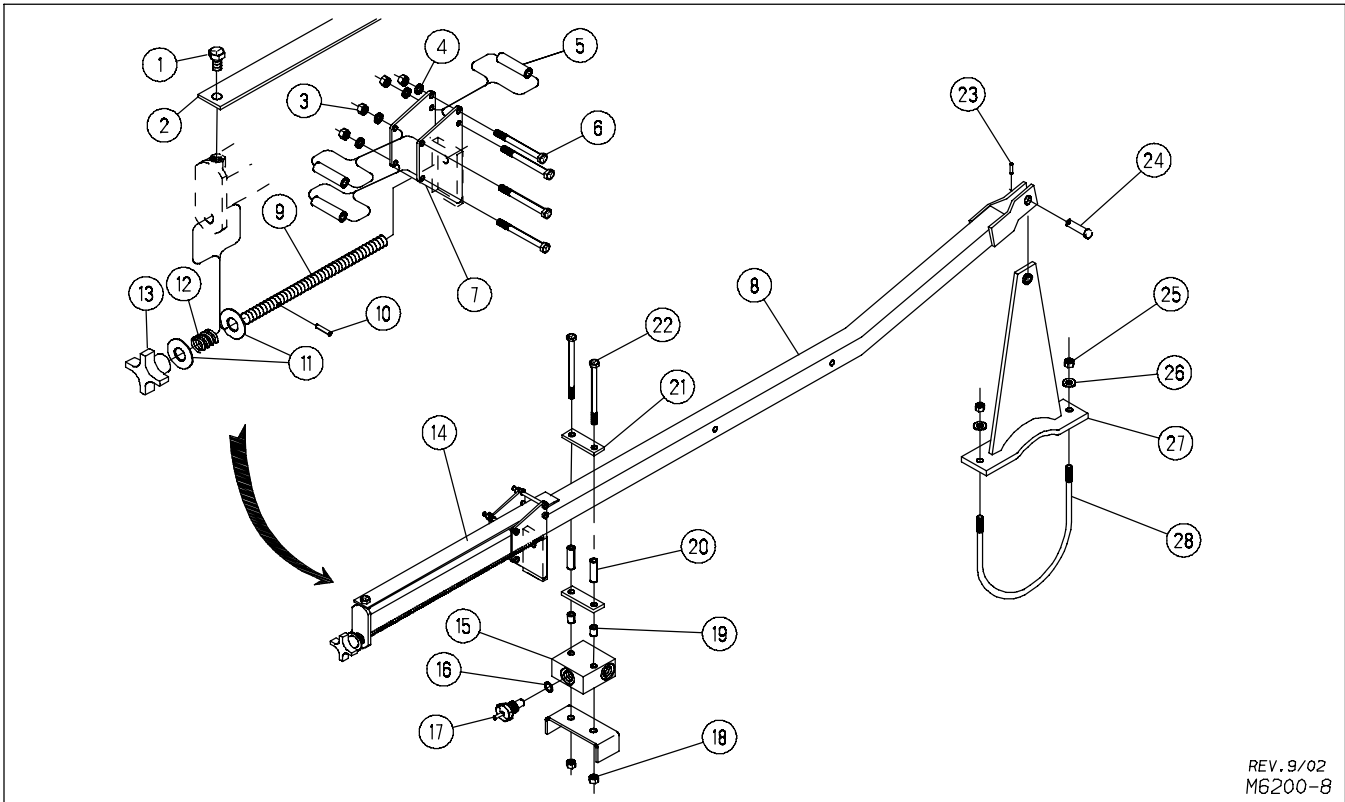

REV. 9/02
M6200-8

FOR MODELS - ALL

2/08

Item	Part Number	Part Description	Qty.
	6202-83-0	Depth Linkage Assembly (Includes ★ Items)	1
1	★ 62-635	3/8NF x 5/8" Cap Screw	1
2	★ 7300-83-5	Guide Slide	1
3	★ 63-100	1/4NC Hex Nut	4
4	★ 64-100	1/4" STD. Lock Washer	4
5	★ 7300-83-3	Striker Spacer	4
6	★ 62-385	1/4NC x 2-1/2" GD5 Cap Screw	4
7	★ 7300-84-0	Striker Weldment	1
8	★ 6202-84-0	Stop Linkage Weldment	1
9	★ 7300-87-0	Threaded Rod Assembly (Includes Item 13 Knob)	1
10	★ 60-632	5/32" DIA. x 3/4" Roll Pin	1
11	★ 64-162	1/2" SAE Flat Washer	2
12	★ 76-102	Spring	1
13	★ 99-215	Knob	1
14	★ 74-489	Depth Decal	1
15	25-2535	Stop Housing Assembly	1
16	25-2537	O-Ring	1
17	25-2436	Cartridge Assembly (includes Item 15 O-Ring)	1
18	63-103	3/8NC Lock Nut	2
19	7300-86-1	Spacer	2
20	3112-69-1	Valve Spacer	2
21	3112-69-2	Bolt Strap	2
22	62-475	3/8NC x 5" GD5 Carriage Bolt	2
23	60-725	5/32" DIA. x 1-1/2" Cotter Pin	1
24	60-211	1/2" DIA. x 1-1/2" Clevis Pin	1
25	63-134	3/8NC Nylon-Top Lock Nut	4
26	64-104	3/8" STD. Flat Washer	2
27	6112-105-0	Actuator Arm Weldment (TL 6200 9, 12, 15)	1
	3112-105-0	Actuator Arm Weldment (TL 6200 18, 21, 24, 27, 36, 42 & 45)	1
28	61-243	3/8" DIA. U-Bolt (TL 6200 9, 12, 15)	1
	61-217	3/8" DIA. U-Bolt (TL 6200 18, 21, 24, 27, 36, 42 & 45)	1

HYDRAULIC HOSE STAND & LOCK VALVE ASSEMBLY

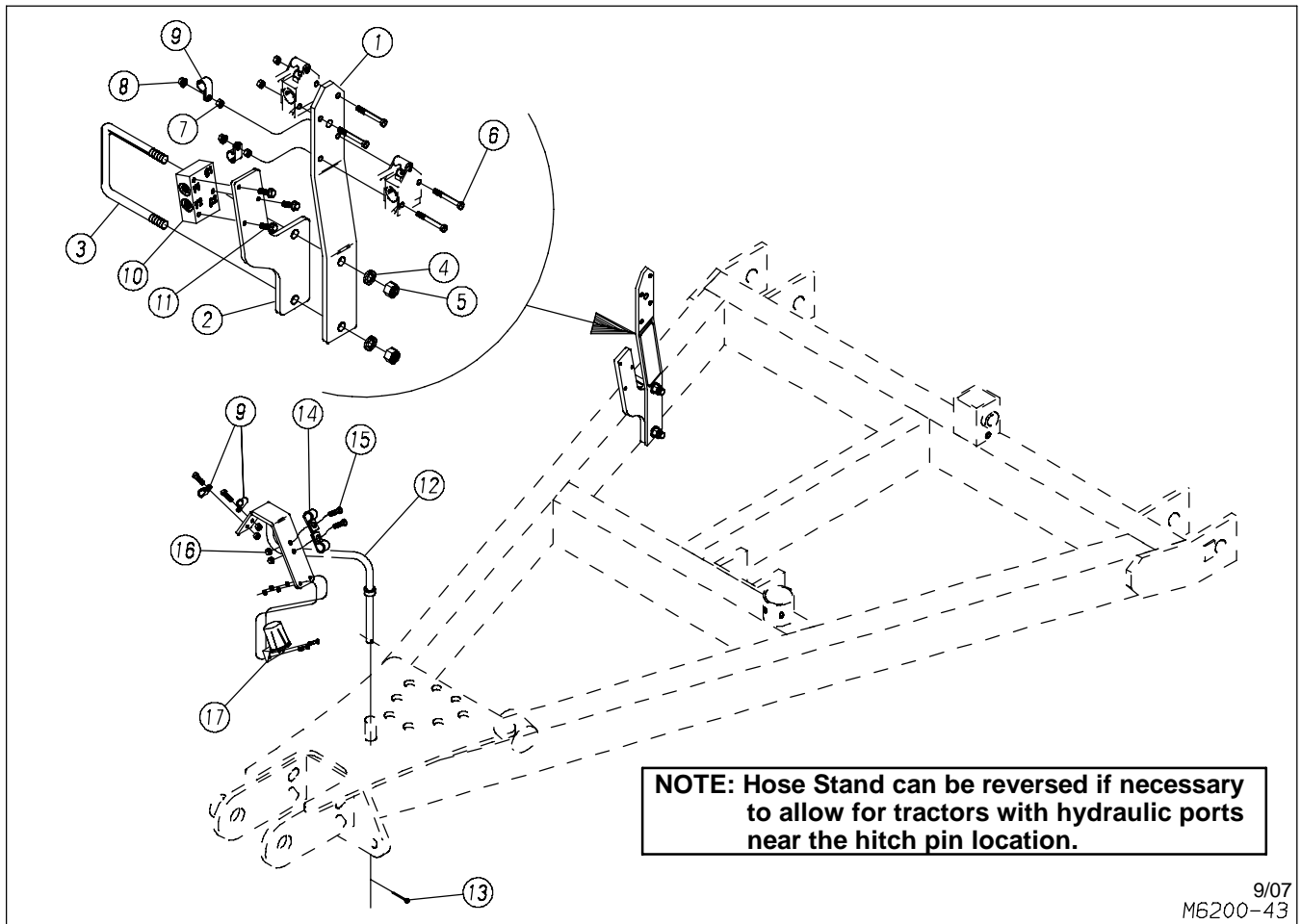

NOTE: Hose Stand can be reversed if necessary to allow for tractors with hydraulic ports near the hitch pin location.

9/07
M6200-43

FOR MODELS - TL 6200

9/03

Item	Part Number	Part Description	Qty.
1	5630-0-8A	Valve Bracket	1
2	■ 6345-0-6	Valve Plate	1
3	● 61-126	U-Bolt 5/8" DIA. x 4-1/16"W x 4-3/8"L	1
	▲ 61-107	U-Bolt 5/8" DIA. x 5-1/16"W x 4-1/2"L	2
	★ 61-127	U-Bolt 5/8" DIA. x 5-1/16"W x 5-3/4"L	1
4	64-109	5/8" STD. Lock Washer	2
5	63-109	5/8NC Hex Nut	2
6	62-394	5/16NC x 2-1/2" GD5 Cap Screw	4
7	63-135	5/16NC Hex Nut	4
8	63-143	5/16NC Hex Flange Serrated Nut	2
9	25-1153	5/8" I.D. Hose Clamp	4
10	■ 25-2278	Valve	1
11	■ 62-510	5/16NC x 3/4" Hex Washer Thread Cutting Screw	3
12	4881-5040-0	Hose Stand Weldment	1
13	60-703	3/16" DIA. x 1-3/4" Cotter Pin	1
14	25-127	3/4" I.D. Hose Clamp	2
15	62-436	3/8NC x 1-1/4" GD5 Cap Screw	4
16	63-134	3/8NC Nylon-Top Lock Nut	4
17		Light Kit Plug Storage Receptacle (included in Light Kit)	
	●	For Rigid Hitch - Models TL 6200 9, 12, 15, 18, 21, 24	
	▲	For Rigid Hitch - Models TL 6200 27, 31, 36, 42, 45	
	★	For Cushion Hitch All Models	
	■	Used for Hydraulic Disc Gang Option	

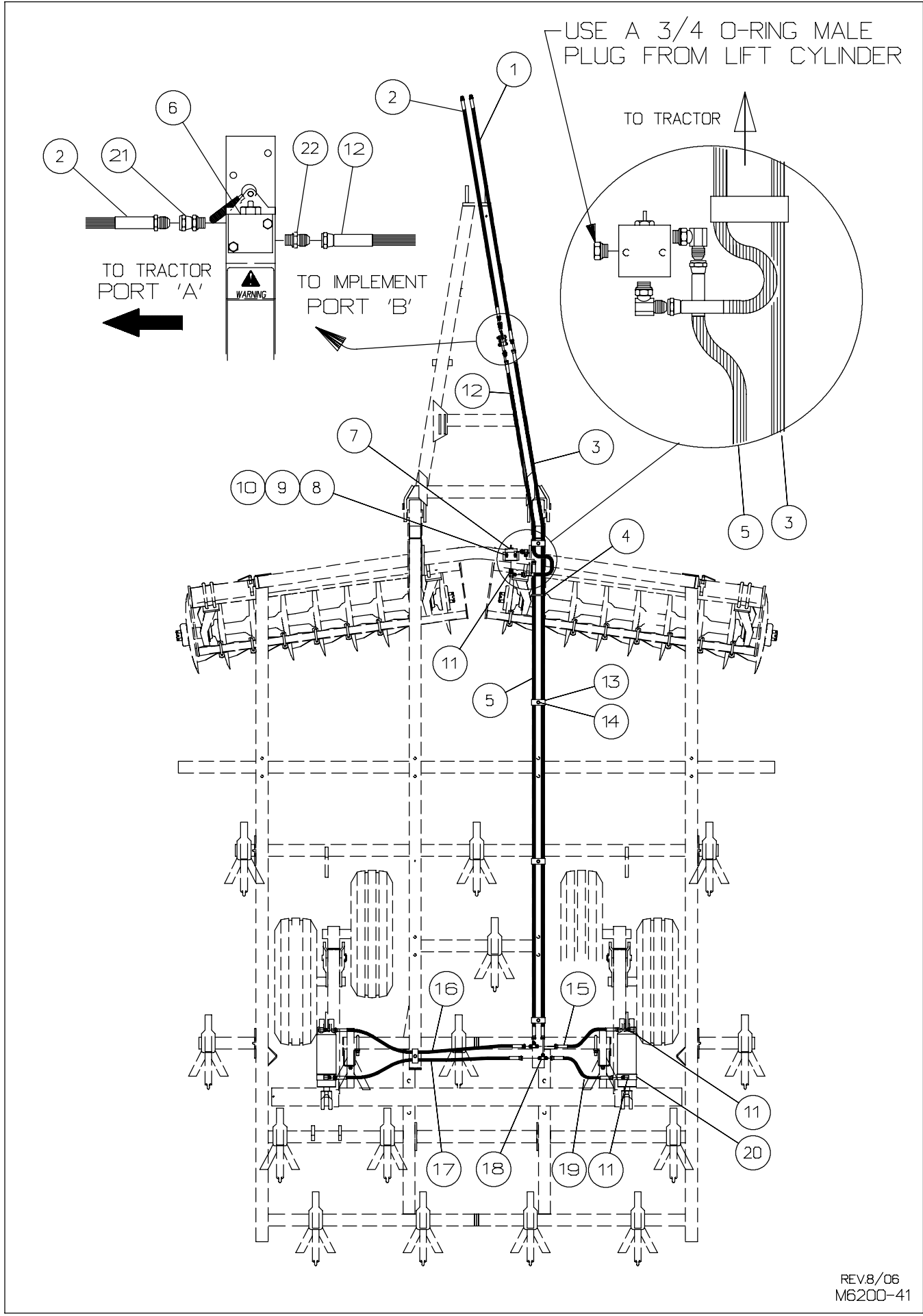

HYDRAULIC HOSE GROUP

FOR MODELS - TL 6200 9, 12 & 15

9/07

<i>Item</i>	<i>Part Number</i>	<i>Part Description</i>	<i>Qty.</i>
1	• 4881-71-0	Hose 1/2" DIA. x 96" 100R2 with Black/Black Grip	1
2	• 4881-77-0	Hose 1/2" DIA. x 96" 100R2 with Red/Black Grip	1
3	24-389R	1/2" DIA. x 210" (JIC) Black 2W Hose Assembly	1
4	25-128	Hose Wraplock	1
5	24-372R	1/2" DIA. x 150" (JIC) Black 2W Hose Assembly	1
6	25-2272	Check Valve - Manual Release	1
7	25-2535	Depth Valve Assembly	1
8	62-356	3/8NC x 2" Carriage Bolt	2
9	64-103	3/8" STD. Lock Washer	2
10	63-102	3/8NC Hex Nut	2
11	25-301	3/4(M)O-Ring to 3/4(M)JIC 90° Hydraulic Fitting	6
12	24-312R	Hose 1/2" DIA. x 80"	1
13	6118-0-3	Hose Clamp	5
14	62-115	3/8NC x 1-1/2" Hex Washer Thread Cutting Screw	5
15	24-200R	3/8" DIA. x 24" (JIC) Black 2W Hose Assembly	1
16	24-207R	3/8" DIA. x 58" (JIC) Black 2W Hose Assembly	1
17	24-244R	3/8" DIA. x 64" (JIC) Black 2W Hose Assembly	1
18	25-303	37° Flare Male Tee	2
19	24-243R	3/8" DIA. x 32" (JIC) Black 2W Hose Assembly	1
20	21-1007	4" x 10" Prince Series Hydraulic Cylinder	2
21	25-300	3/4(M)O-Ring to 3/4(M)JIC Adapter Hydraulic Fitting	1
22	25-314	3/4(M)O-Ring to 3/4(F)JIC Swivel Adapter Hydraulic Fitting	1
<ul style="list-style-type: none"> • See page P64 for Parts Listing 			

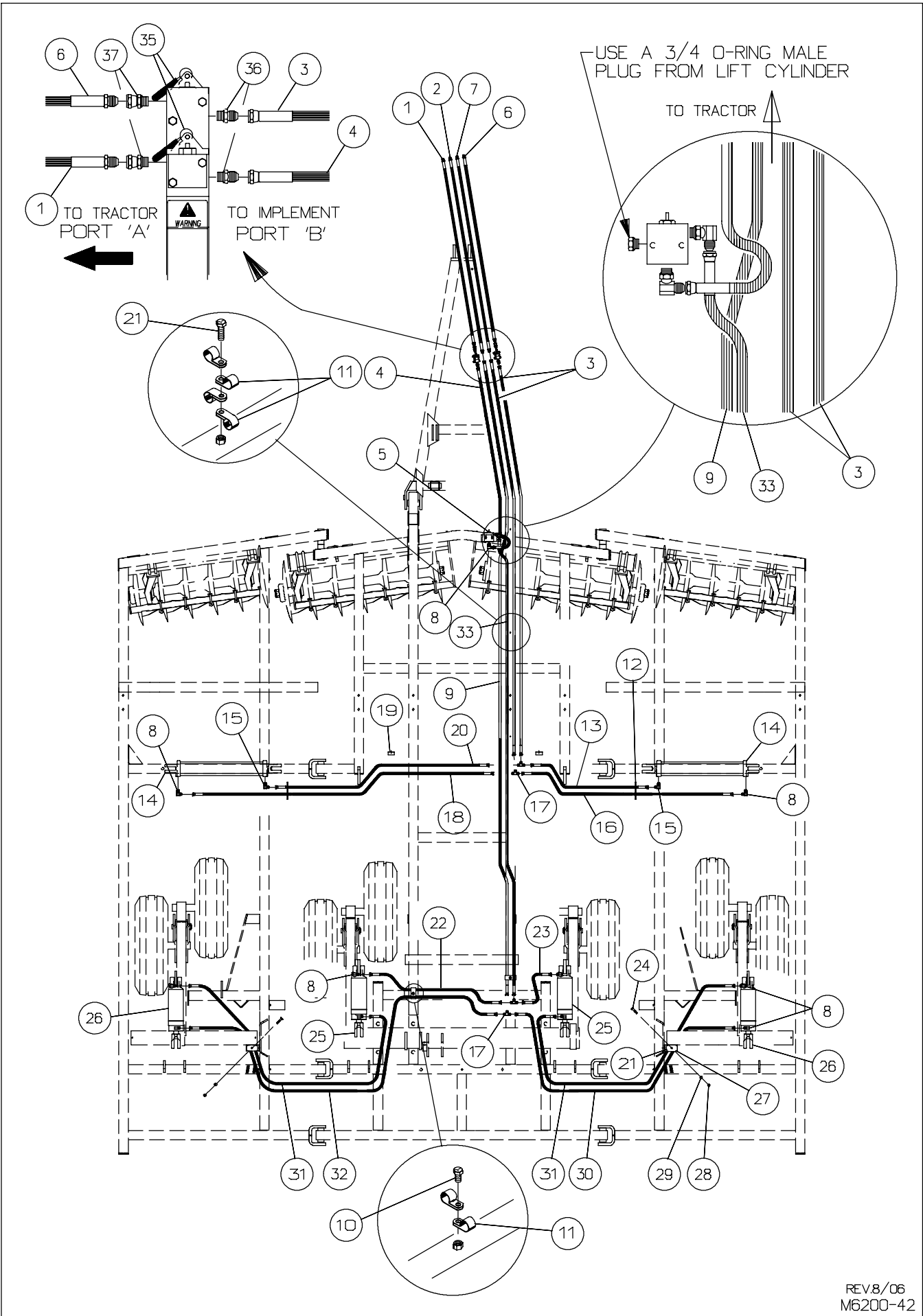

HYDRAULIC HOSE GROUP

FOR MODELS - TL 6200 18 & 21

9/07

<i>Item</i>	<i>Part Number</i>	<i>Part Description</i>	<i>Qty.</i>
1	● 4881-77-0	1/2" DIA. x 96" Hose & Grip Assembly - Red/Black Grip	1
2	● 4881-71-0	1/2" DIA. x 96" Hose & Grip Assembly - Black/Black Grip	1
3	24-2115R	3/8" DIA. x 156" (JIC) Black 2W Hose Assembly	2
4	24-390R	1/2" DIA. x 96" (JIC) Black 2W Hose Assembly	1
5	25-2535	Depth Valve Assembly	1
6	● 4881-70-0	3/8" DIA. x 96" Hose & Grip Assembly - Red/Yellow Grip	1
7	● 4881-76-0	3/8" DIA. x 96" Hose & Grip Assembly - Yellow/Yellow Grip	1
8	25-301	3/4(M)O-Ring to 3/4(M)JIC 90° Hydraulic Fitting	12
9	24-338R	1/2" DIA. x 228" (JIC) Black 2W Hose Assembly	1
10	62-635	3/8NF x 5/8" GD5 Cap Screw	4
11	25-127	3/4" I.D. Hose Clamp	20
12	25-128	Hose Wraplock (Use where required)	
13	24-256R	3/8" DIA. x 48" (JIC) Black 2W Hose Assembly	1
14	21-181	4" x 24" Prince Hydraulic Cylinder Assembly	2
15	4956-75-0	O-Ring 37° Flare 90° Restrictor Assembly w/ Tag	2
16	24-210R	3/8" DIA. x 76" (JIC) Black 2W Hose Assembly	1
17	25-303	37° Flare 3/4(M) Tee Hydraulic Fitting	4
18	24-279R	3/8" DIA. x 112" (JIC) Black 2W Hose Assembly	1
19	3127-83-1	Hose Clamp	2
20	24-257R	3/8" DIA. x 80" (JIC) Black 2W Hose Assembly	1
21	62-692	3/8NF x 1" GD5 Cap Screw	3
22	24-207R	3/8" DIA. x 58" (JIC) Black 2W Hose Assembly	1
23	24-200R	3/8" DIA. x 24" (JIC) Black 2W Hose Assembly	1
24	62-343	1/2NC x 2" GD5 Cap Screw	2
25	21-1007	4" x 10" Series Hydraulic Cylinder Assembly	2
26	21-1006	3-3/4" x 10" Prince Series Hydraulic Cylinder Assembly	2
27	6118-0-1	Hose Bracket	2
28	63-106	1/2NC Hex Nut	2
29	64-107	1/2" STD. Lock Washer	2
30	24-223R	3/8" DIA. x 128" (JIC) Black 2W Hose Assembly	1
31	24-237R	3/8" DIA. x 124" (JIC) Black 2W Hose Assembly	2
32	24-299R	3/8" DIA. x 162" (JIC) Black 2W Hose Assembly	1
33	24-372R	1/2" DIA. x 150" (JIC) Black 2W Hose Assembly	1
34	25-126	34" Black Stay Strap (use as needed) - not shown	6
35	25-2272	Check Valve - Manual Release	2
36	25-300	3/4(M)O-Ring to 3/4(M)JIC Adapter Hydraulic Fitting	2
37	25-314	3/4(M)O-Ring to 3/4(F)JIC Swivel Adapter Hydraulic Fitting	2
<ul style="list-style-type: none"> ● See page P64 for parts listing 			

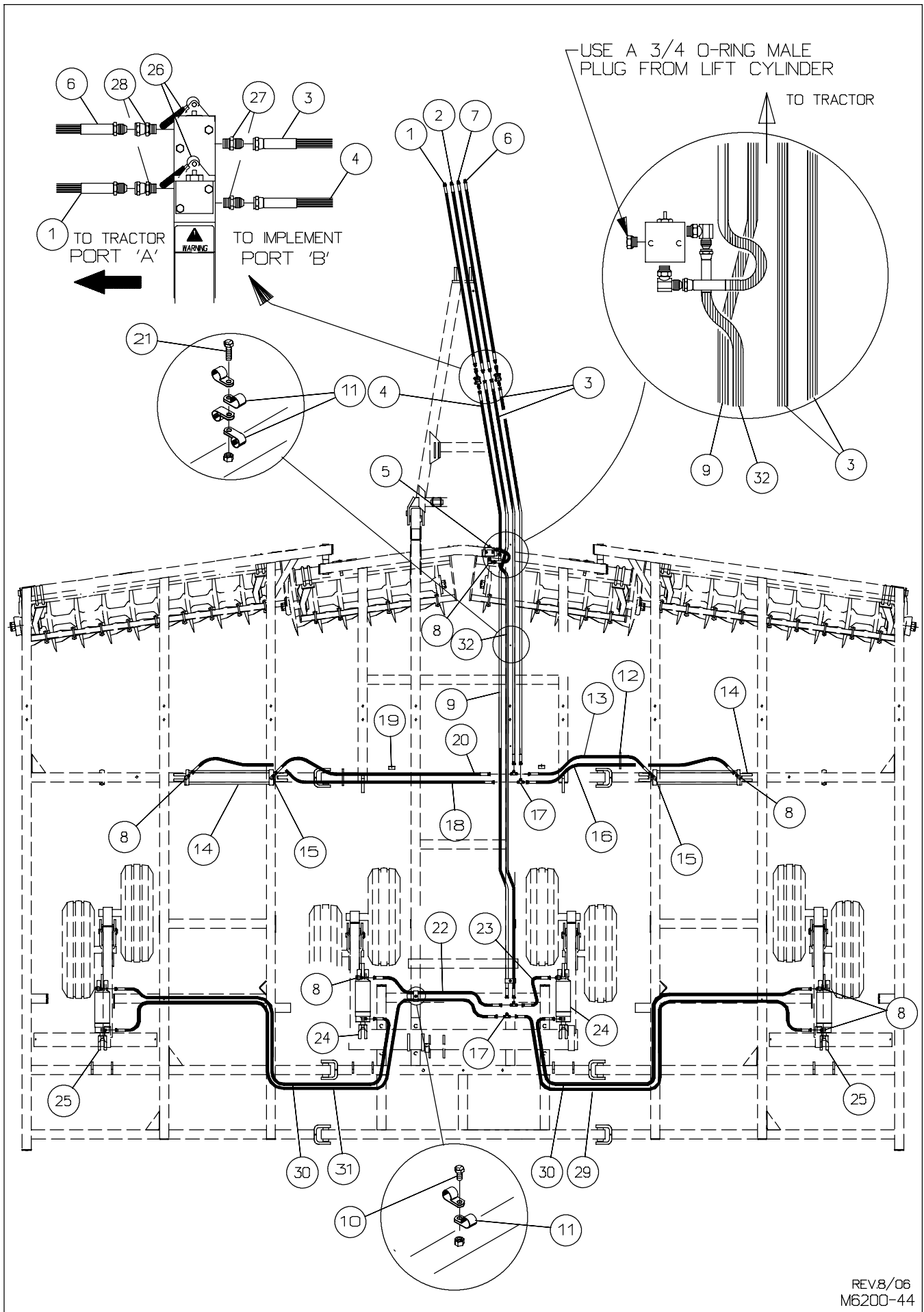

REV.8/06
M6200-44

HYDRAULIC HOSE GROUP

FOR MODELS - TL 6200 24

9/07

<i>Item</i>	<i>Part Number</i>	<i>Part Description</i>	<i>Qty.</i>
1	● 4881-77-0	1/2" DIA. x 96" Hose & Grip Assembly - Red/Black	1
2	● 4881-71-0	1/2" DIA. x 96" Hose & Grip Assembly - Black/Black	1
3	24-241R	3/8" DIA. x 154" (JIC) Black 2W Hose Assembly	2
4	24-390R	1/2" DIA. x 93" (JIC) Black 2W Hose Assembly	1
5	25-2535	Depth Valve Assembly	1
6	● 4881-70-0	3/8" DIA. x 96" Hose & Grip Assembly - Red/Yellow	1
7	● 4881-76-0	3/8" DIA. x 96" Hose & Grip Assembly - Yellow/Yellow	1
8	25-301	3/4(M)O-Ring to 3/4(M)JIC 90° Hydraulic Fitting	12
9	24-338R	1/2" DIA. x 228" (JIC) Black 2W Hose Assembly	1
10	62-635	3/8NF x 5/8" GD5 Cap Screw	4
11	25-127	3/4" I.D. Hose Clamp	20
12	25-128	Hose Wraplock (Use where required)	2
13	24-207R	3/8" DIA. x 58" (JIC) Black 2W Hose Assembly	1
14	21-182	4" x 32" Prince Hydraulic Cylinder Assembly	2
15	4956-75-0	O-Ring 37° Flare 90° Restrictor Assembly w/ Tag	2
16	24-217R	3/8" DIA. x 92" (JIC) Black 2W Hose Assembly	1
17	25-303	37° Flare 3/4(M) Tee Hydraulic Fitting	4
18	24-291R	3/8" DIA. x 120" (JIC) Black 2W Hose Assembly	1
19	3127-83-1	Hose Clamp	2
20	24-213R	3/8" DIA. x 88" (JIC) Black 2W Hose Assembly	1
21	62-692	3/8NF x 1" GD5 Cap Screw	3
22	24-207R	3/8" DIA. x 58" (JIC) Black 2W Hose Assembly	1
23	24-200R	3/8" DIA. x 24" (JIC) Black 2W Hose Assembly	1
24	21-1007	4" x 10" Prince Series Hydraulic Cylinder Assembly	2
25	21-1006	3-3/4" x 10" Prince Series Hydraulic Cylinder Assembly	2
26	25-2272	Check Valve - Manual Release	2
27	25-300	3/4(M)O-Ring to 3/4(M)JIC Adapter Hydraulic Fitting	2
28	25-314	3/4(M)O-Ring to 3/4(F)JIC Swivel Adapter Hydraulic Fitting	2
29	24-2115R	3/8" DIA. x 156" (JIC) Black 2W Hose Assembly	1
30	24-225R	3/8" DIA. x 140" (JIC) Black 2W Hose Assembly	2
31	24-2101R	3/8" DIA. x 186" (JIC) Black 2W Hose Assembly	1
32	24-372R	1/2" DIA. x 150" (JIC) Black 2W Hose Assembly	1
33	25-126	34" Black Stay Strap (use as needed) - not shown	
● See page P64 for parts listing			

TO TRACTOR

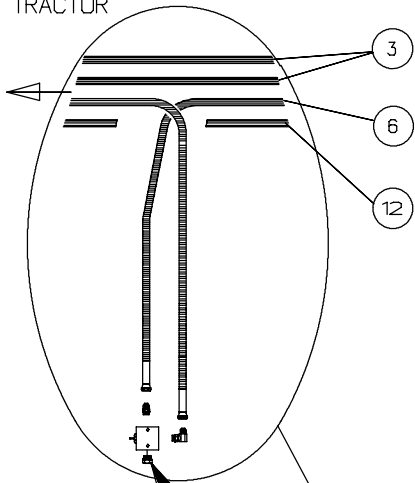

USE A 3/4 O-RING
MALE PLUG FROM
LIFT CYLINDER

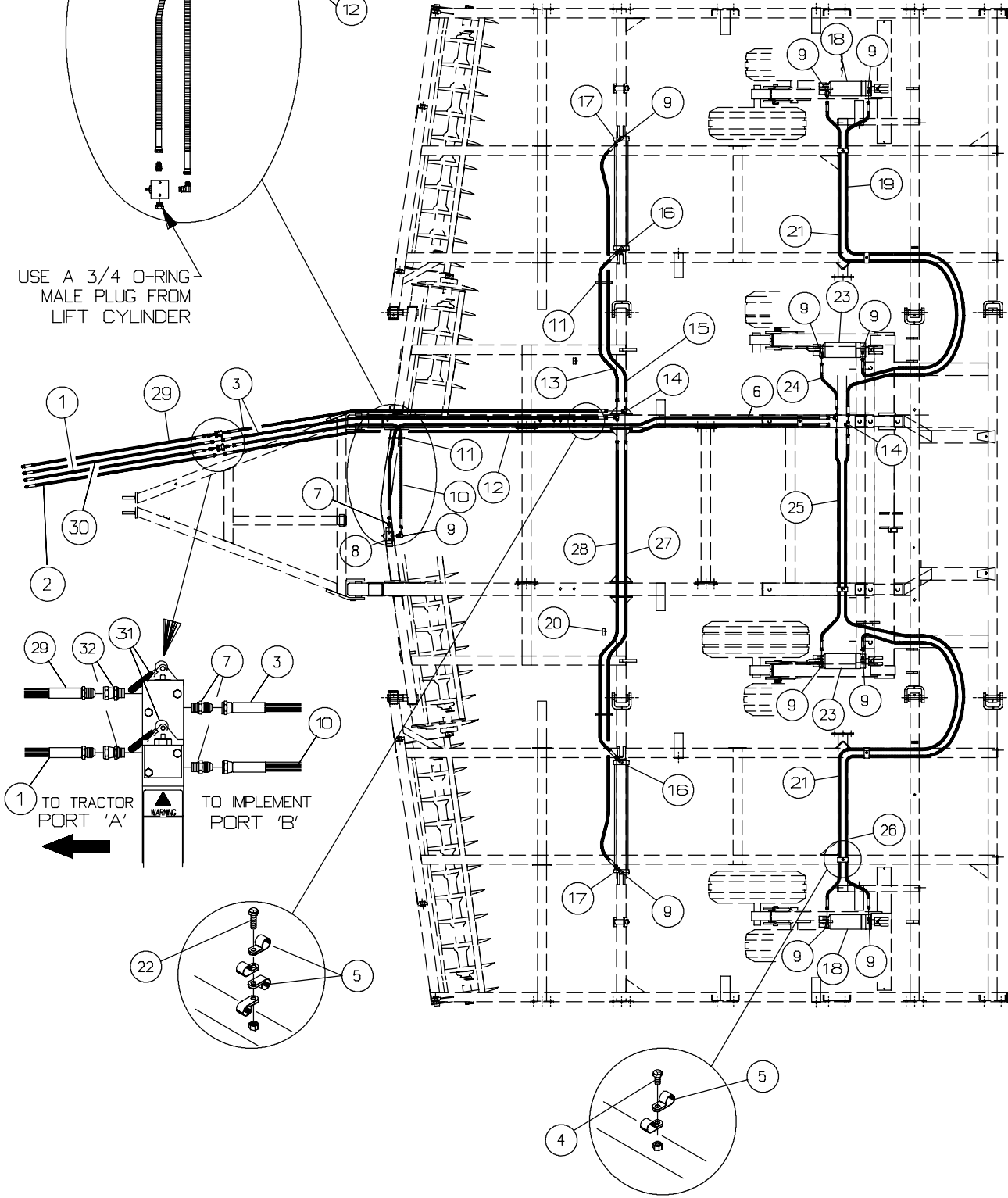

Rev.8/06
M6200-45

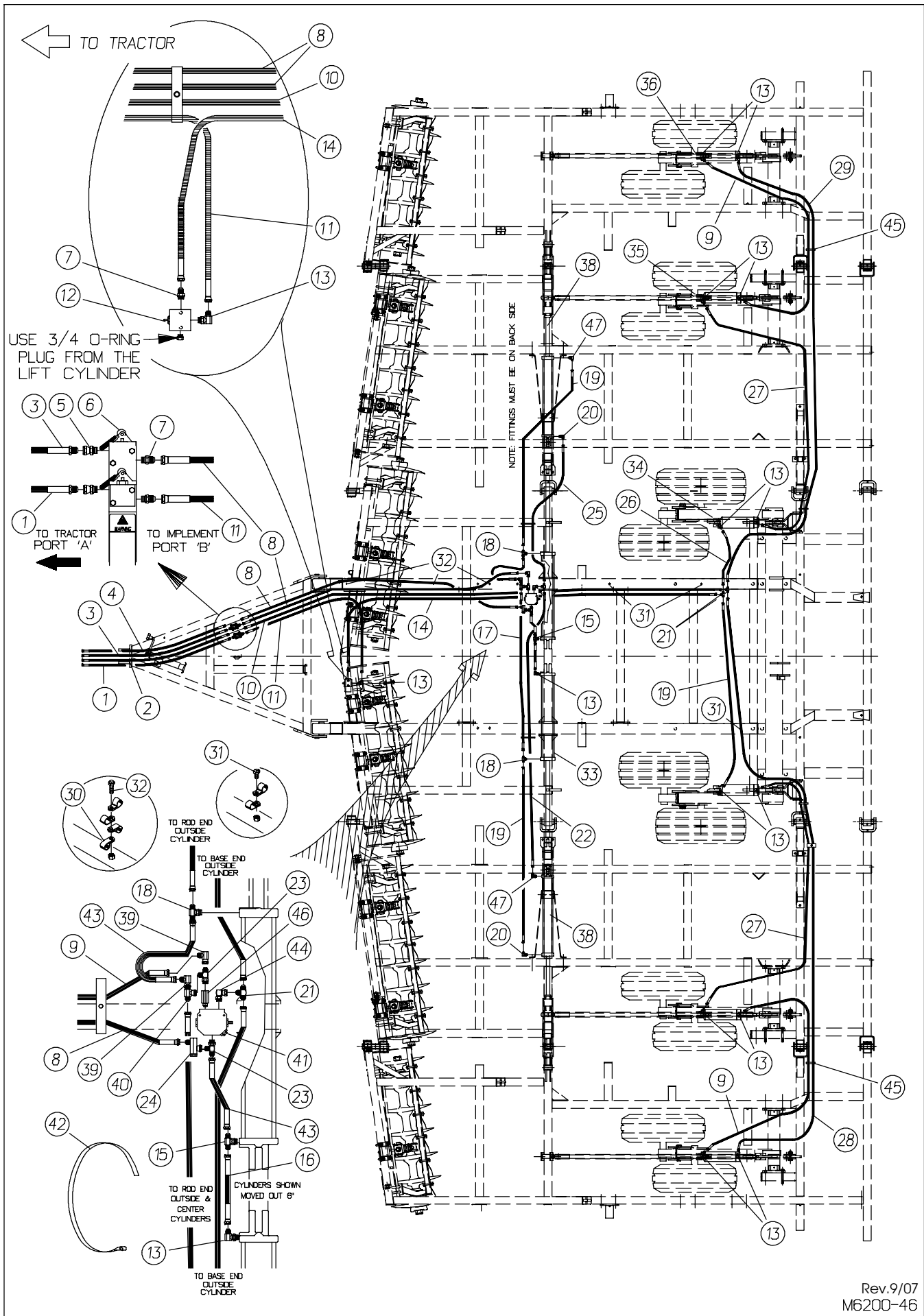

HYDRAULIC HOSE GROUP

FOR MODELS - TL 6200 36

9/07

Item	Part Number	Part Description	Qty.
1	● 4881-77-0	1/2" DIA. x 96" Hose & Grip Assembly - Red/Black	1
2	● 4881-71-0	1/2" DIA. x 96" Hose & Grip Assembly - Black/Black	1
3	● 4881-70-0	3/8" DIA. x 96" Hose & Grip Assembly - Red/Yellow	1
4	● 4881-76-0	3/8" DIA. x 96" Hose & Grip Assembly - Yellow/Yellow	1
5	25-314	3/4(M)O-Ring to 3/4(F)JIC Swivel Adapter Hydraulic Fitting	2
6	25-2272	Check Valve - Manual Release	2
7	25-300	3/4(M)O-Ring to 3/4(M)JIC Adapter Hydraulic Fitting	3
8	24-286R	3/8" DIA. x 168" (JIC) Black 2W Hose Assembly	2
9	24-265R	3/8" DIA. x 136" (JIC) Black 2W Hose Assembly	2
10	24-311R	1/2" DIA. x 246" (JIC) Black 2W Hose Assembly	1
11	24-325R	1/2" DIA. x 140" (JIC) Black 2W Hose Assembly	1
12	25-2535	Depth Valve	1
13	25-301	3/4(M)O-Ring to 3/4(M)JIC 90° Hydraulic Fitting	14
14	24-368R	1/2" DIA. x 180" (JIC) Black 2W Hose Assembly	1
15	25-309	O-Ring 37° Flare Tee Hydraulic Fitting	1
16	24-264R	3/8" DIA. x 14" (JIC) Black 2W Hose Assembly	1
17	24-288R	3/8" DIA. x 72" (JIC) Black 2W Hose Assembly	1
18	3775-75-0	O-Ring 37° Flare Tee Restrictor (25-306) w/ Tag	2
19	24-261R	3/8" DIA. x 84" (JIC) Black 2W Hose Assembly	3
20	4956-75-0	O-Ring 37° Flare 90° Restrictor Fitting w/ Tag	4
21	25-303	37° Flare 3/4(M) Tee Hydraulic Fitting	3
22	24-237R	3/8" DIA. x 124" (JIC) Black 2W Hose Assembly	1
23	25-302	O-Ring 37° Flare Tee Hydraulic Fitting	2
24	25-324	37° Flare M/F In-Line Restrictor Hydraulic Fitting	1
25	24-2114R	3/8" DIA. x 60" (JIC) Black 2W Hose Assembly	1
26	24-268R	3/8" DIA. x 28" (JIC) Black 2W Hose Assembly	1
27	24-286R	3/8" DIA. x 168" (JIC) Black 2W Hose Assembly	2
28	24-2128R	3/8" DIA. x 270" (JIC) Black 2W Hose Assembly	1
29	24-263R	3/8" DIA. x 228" (JIC) Black 2W Hose Assembly	1
30	25-127	3/4" I.D. Hose Clamp	34
31	62-635	3/8NF x 5/8" GD5 Cap Screw	8
32	62-692	3/8NF x 1" GD5 Cap Screw	3
33	21-189	5" x 32" Prince Hydraulic Cylinder Assembly	2
34	21-1008	4-1/4" x 10" Prince Series Cylinder Assembly	2
35	21-1007	4" x 10" Prince Series Cylinder Assembly	2
36	21-1006	3-3/4" x 10" Prince Series Cylinder Assembly	2
37	25-126	3/4" Black Stay Strap (use as needed) - Not shown	6
38	See Page P45	Wing Lift Hydraulic Cylinder Assembly	2
39	25-310	3/4(M)JIC to 3/4(F)JIC 90° Swivel Hydraulic Fitting	2
40	25-373	3/4 JIC Swivel Nut Branch Tee Hydraulic Fitting	1
41	25-144	Sequence Valve 3M PSI	1
42	25-1105	Snaplock Clamp (Bands Sequence Valve to Frame)	1
43	24-268R	3/8" DIA. x 28" (JIC) Black 2W Hose Assembly	2
44	25-320	3/4(M)O-Ring to 37° Flare 90° (F) 3/4JIC Swivel Hydraulic Fitting	1
45	25-128	Hose Wrap Lock	2
46	25-2512	Check Valve, In-Line	1
47	6236-75-0	3/32 Restrictor w/ Tag	2
<p>● See page P64 for parts listing</p>			

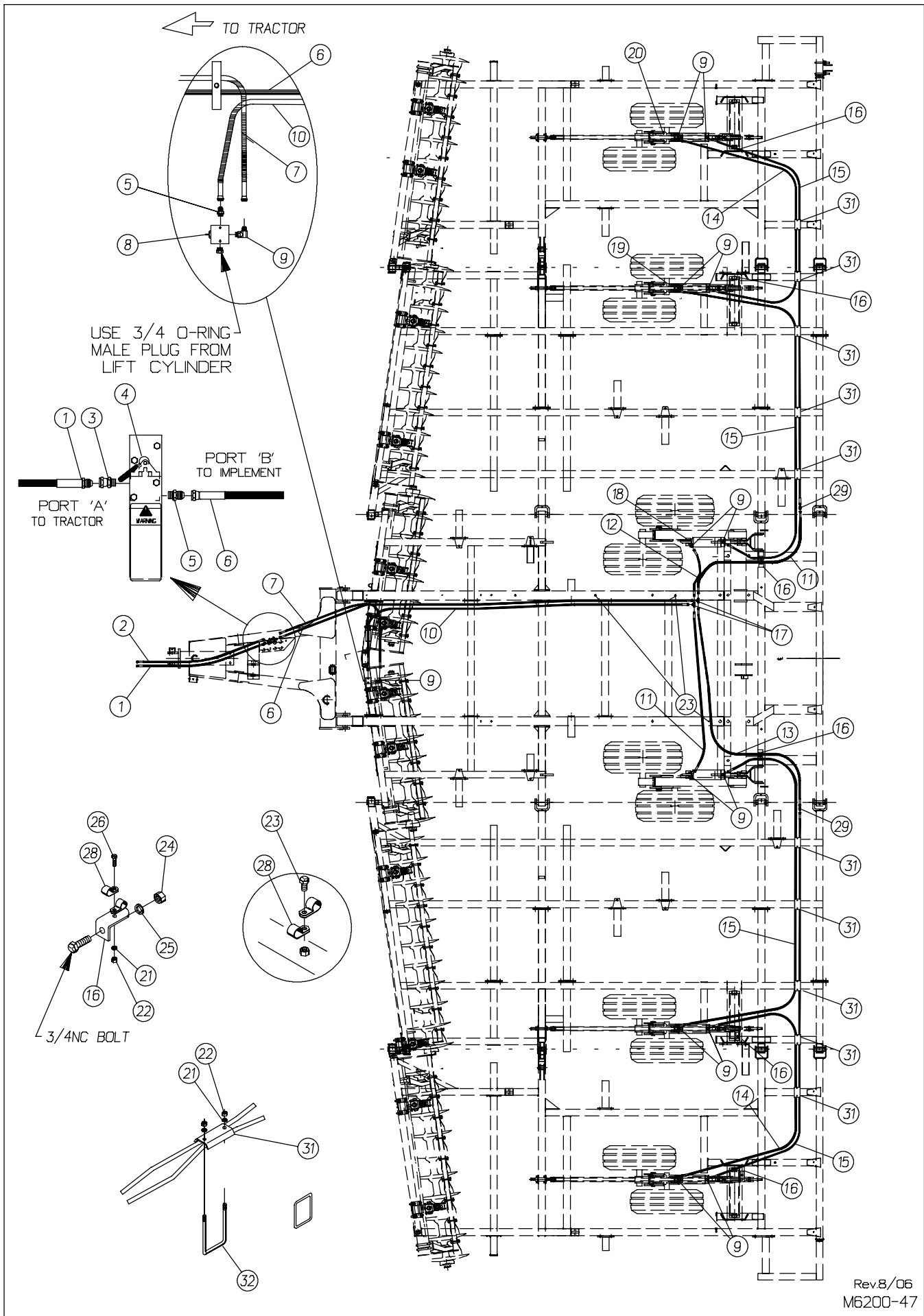

Rev.8/06
M6200-47

HYDRAULIC HOSE GROUP - ROCKERS

FOR MODELS - TL 6200 42 & 45

9/07

Item	Part Number	Part Description	Qty.
1	● 4881-77-0	1/2" DIA. x 96" Hose & Grip Assembly - Red/Black	1
2	● 4881-71-0	1/2" DIA. x 96" Hose & Grip Assembly - Black/Black	1
3	25-314	3/4(M)O-Ring to 3/4(F)JIC Swivel Adapter Hydraulic Fitting	1
4	25-2272	Check Valve - Manual Release	1
5	25-300	3/4(M)O-Ring to 3/4(M)JIC Adapter Hydraulic Fitting	2
6	24-311R	1/2" DIA. x 246" (JIC) Black 2W Hose Assembly	1
7	24-325R	1/2" DIA. x 140" (JIC) Black 2W Hose Assembly	1
8	25-2535	Depth Valve Assembly	1
9	25-301	3/4(M)O-Ring to 3/4(M)JIC 90° Hydraulic Fitting	12
10	24-368R	1/2" DIA. x 180" (JIC) Black 2W Hose Assembly	1
11	24-261R	3/8" DIA. x 84" (JIC) Black 2W Hose Assembly	2
12	24-268R	3/8" DIA. x 28" (JIC) Black 2W Hose Assembly	1
13	24-265R	3/8" DIA. x 136" (JIC) Black 2W Hose Assembly	1
14	24-2115R	3/8" DIA. x 156" (JIC) Black 2W Hose Assembly	2
15	24-282R	3/8" DIA. x 198" (JIC) Black 2W Hose Assembly	4
16	4809-0-2	Hose Bracket	6
17	25-303	37° Flare Male Tee Hydraulic Fitting	2
18	21-1008	4-1/4" x 10" Prince Series Hydraulic Cylinder Assembly	2
19	21-1007	4" x 10" Prince Series Hydraulic Cylinder Assembly	2
20	21-1006	3-3/4" x 10" Prince Series Hydraulic Cylinder Assembly	2
21	64-103	3/8" STD. Lock Washer	42
22	63-311	3/8NC Hex Nut - Black	42
23	62-635	3/8NF x 5/8" GD5 Cap Screw	3
24	63-112	3/4NC Hex Nut	2
25	64-112	3/4" STD. Lock Washer	2
26	62-108	3/8NC x 1" GD5 Cap Screw	2
27	62-421	3/4NC x 2" GD5 Cap Screw (not shown)	2
28	25-1153	5/8" I.D. Hose Clamp	10
29	25-304	37° Flare Male Coupler Hydraulic Fitting	2
30	25-126	34" UV Black Stay Strap (Use as required) - Not Shown	Spec.
31	6345-0-2	Hose Clamp	10
32	61-275	U-Bolt, 3/8" DIA. x 3-1/16"W x 5-1/2"L	10

- See page P64 for parts listing

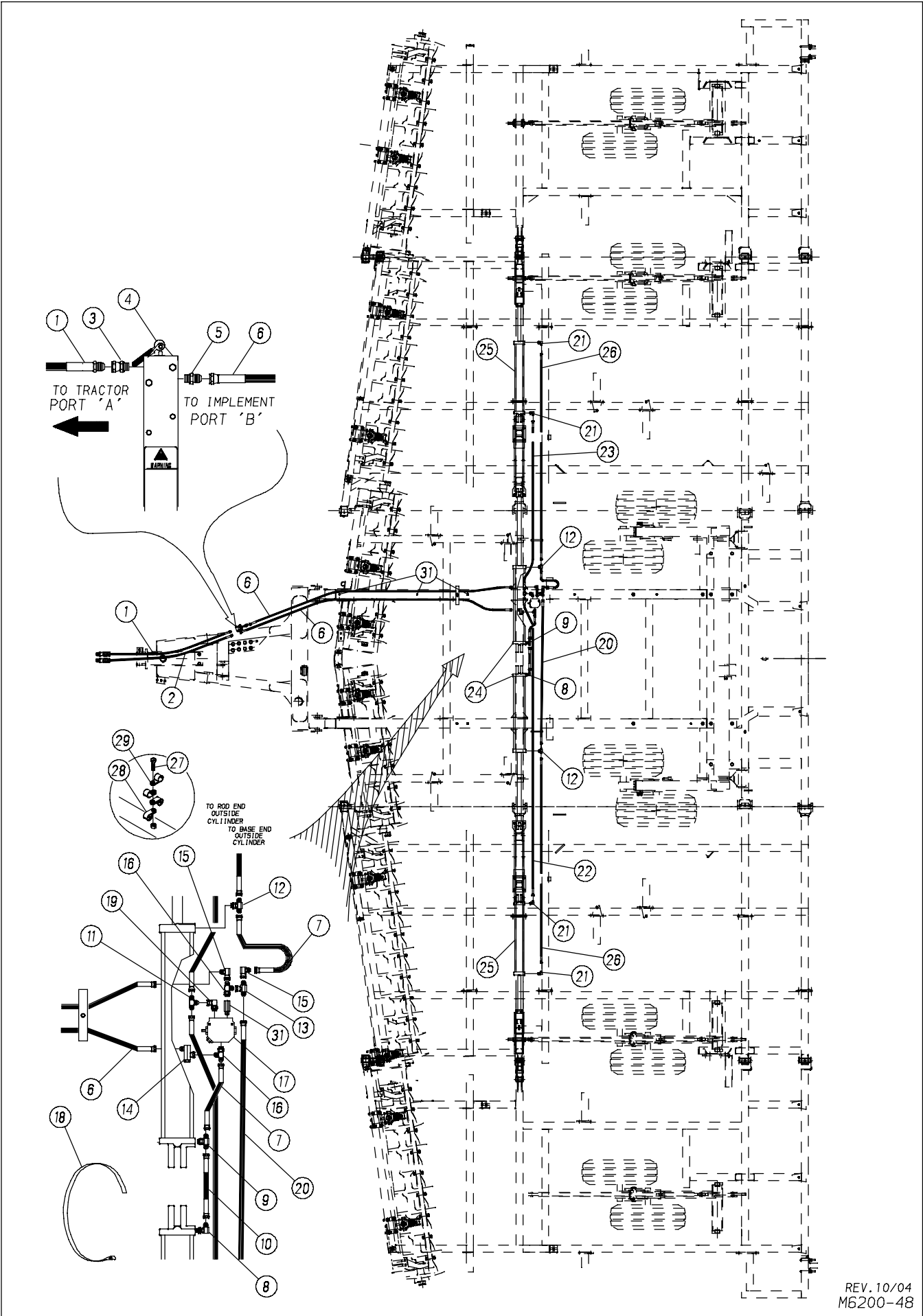

HYDRAULIC HOSE GROUP - WING FOLD

FOR MODELS - TL 6200 42 & 45

9/07

<i>Item</i>	<i>Part Number</i>	<i>Part Description</i>	<i>Qty.</i>
1	● 4881-70-0	3/8" DIA. x 96" Hose & Grip Assembly - Red/Yellow	1
2	● 4881-76-0	3/8" DIA. x 96" Hose & Grip Assembly - Yellow/Yellow	1
3	25-314	3/4(M)O-Ring to 3/4(F)JIC Swivel Adapter Hydraulic Fitting	1
4	25-2272	Check Valve - Manual Release	1
5	25-300	3/4(M)O-Ring to 3/4(M)JIC Adapter Hydraulic Fitting	1
6	★ 24-286R	3/8" DIA. x 168" (JIC) Black 2W Hose Assembly	2
7	24-268R	3/8" DIA. x 28" (JIC) Black 2W Hose Assembly	2
8	25-301	3/4(M)O-Ring to 3/4(M)JIC 90° Hydraulic Fitting	1
9	25-309	O-Ring 37° Flare Tee Hydraulic Fitting	1
10	24-264R	3/8" DIA. x 14" (JIC) Black 2W Hose Assembly	1
11	25-303	37° Flare 3/4(M) Tee Hydraulic Fitting	1
12	3775-75-0	O-Ring 37° Flare Tee Restrictor Assembly w/ Tag	2
13	25-373	3/4 JIC Swivel Nut Branch Tee Hydraulic Fitting	1
14	25-324	37° Flare M/F In-Line Restrictor Hydraulic Fitting	1
15	25-310	3/4(M)JIC to 3/4(F)JIC 90° Swivel Hydraulic Fitting	2
16	25-302	O-Ring 37° Flare Tee Hydraulic Fitting	2
17	25-144	Sequence Valve 3M PSI	1
18	25-1105	Snaplock Clamp (bands sequence valve to frame)	1
19	25-320	3/4(M)O-Ring to 37° Flare 90° (F) 3/4JIC Swivel Hydraulic Fitting	1
20	24-210R	3/8" DIA. x 76" (JIC) Black 2W Hose Assembly	1
21	4956-75-0	O-Ring 37° Flare 90° Restrictor Assembly w/ Tag	4
22	24-283R	3/8" DIA. x 144" (JIC) Black 2W Hose Assembly	1
23	24-217R	3/8" DIA. x 92" (JIC) Black 2W Hose Assembly	1
24	21-189	5" x 32" Prince Hydraulic Cylinder Assembly	2
25	See Page P47	Hydraulic Wing Lift Cylinder Assembly	2
26	24-2106R	3/8" DIA. x 104" (JIC) Black 2W Hose Assembly	2
27	62-692	3/8NF x 1" GD5 Cap Screw	3
28	25-127	3/4" I.D. Hose Clamp	9
29	25-1153	5/8" I.D. Hose Clamp	12
30	25-128	Hose Wrap Lock (not shown - use as needed)	Spec.
31	25-2512	Check Valve, In-Line	1
<ul style="list-style-type: none"> ● See page P64 for parts listing 			

HYDRAULIC HOSE WITH PLASTIC GRIP ASSEMBLIES

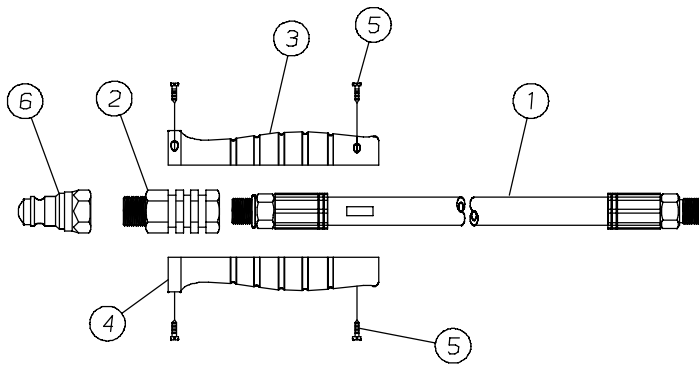

REV 7/01
M4881-23

FOR MODELS - ALL

9/07

Item	Part Number	Part Description	Qty.
	4881-70-0	3/8" x 96" 100R2 Hose with Red/Yellow Grip Assembly	1
1	24-2105R	3/8" x 96" JIC/ORB 100R2 Hose	1
2	25-2295	3/4 ORB to 1/2 NPT Hydraulic Fitting	1
3	25-2289	Hose Grip Half - Red	1
4	25-2290	Hose Grip Half - Yellow	1
5	62-656	Screw	4
6	25-221	Male Coupler	1
	4881-71-0	1/2" x 96" 100R2 Hose with Black/Black Grip Assembly	1
1	24-330R	1/2" DIA. x 96" JIC/ORB 100R2 Hose	1
2	25-2295	3/4 ORB to 1/2 NPT Hydraulic Fitting	1
3	25-2291	Hose Grip Half - Black	1
4	25-2291	Hose Grip Half - Black	1
5	62-656	Screw	4
6	25-221	Male Coupler	1
	4881-74-0	3/8" x 96" 100R2 Hose with Red/Gray Grip Assembly	1
1	24-2105R	3/8" x 96" JIC/ORB 100R2 Hose	1
2	25-2295	3/4 ORB to 1/2 NPT Hydraulic Fitting	1
3	25-2289	Hose Grip Half - Red	1
4	25-2510	Hose Grip Half - Gray	1
5	62-656	Screw	4
6	25-221	Male Coupler	1
	4881-75-0	3/8" x 96" 100R2 Hose with Gray/Gray Grip Assembly	1
1	24-2105R	3/8" x 96" JIC/ORB 100R2 Hose	1
2	25-2295	3/4 ORB to 1/2 NPT Hydraulic Fitting	1
3	25-2510	Hose Grip Half - Gray	1
4	25-2510	Hose Grip Half - Gray	1
5	62-656	Screw	4
6	25-221	Male Coupler	1
	4881-76-0	3/8" x 96" 100R2 Hose with Yellow/Yellow Grip Assembly	1
1	24-2105R	3/8" DIA. x 96" JIC/ORB 100R2 Hose	1
2	25-2295	3/4 ORB to 1/2 NPT Hydraulic Fitting	1
3	25-2290	Hose Grip Half - Yellow	1
4	25-2290	Hose Grip Half - Yellow	1
5	62-656	Screw	4
6	25-221	Male Coupler	1
	4881-77-0	1/2" x 96" 100R2 Hose with Red/Black Grip Assembly	1
1	24-330R	1/2" x 96" JIC/ORB 100R2 Hose	1
2	25-2295	3/4 ORB to 1/2 NPT Hydraulic Fitting	1
3	25-2289	Hose Grip Half - Red	1
4	25-2291	Hose Grip Half - Black	1
5	62-656	Screw	4
6	25-221	Male Coupler	1

PRINCE HYDRAULIC CYLINDER

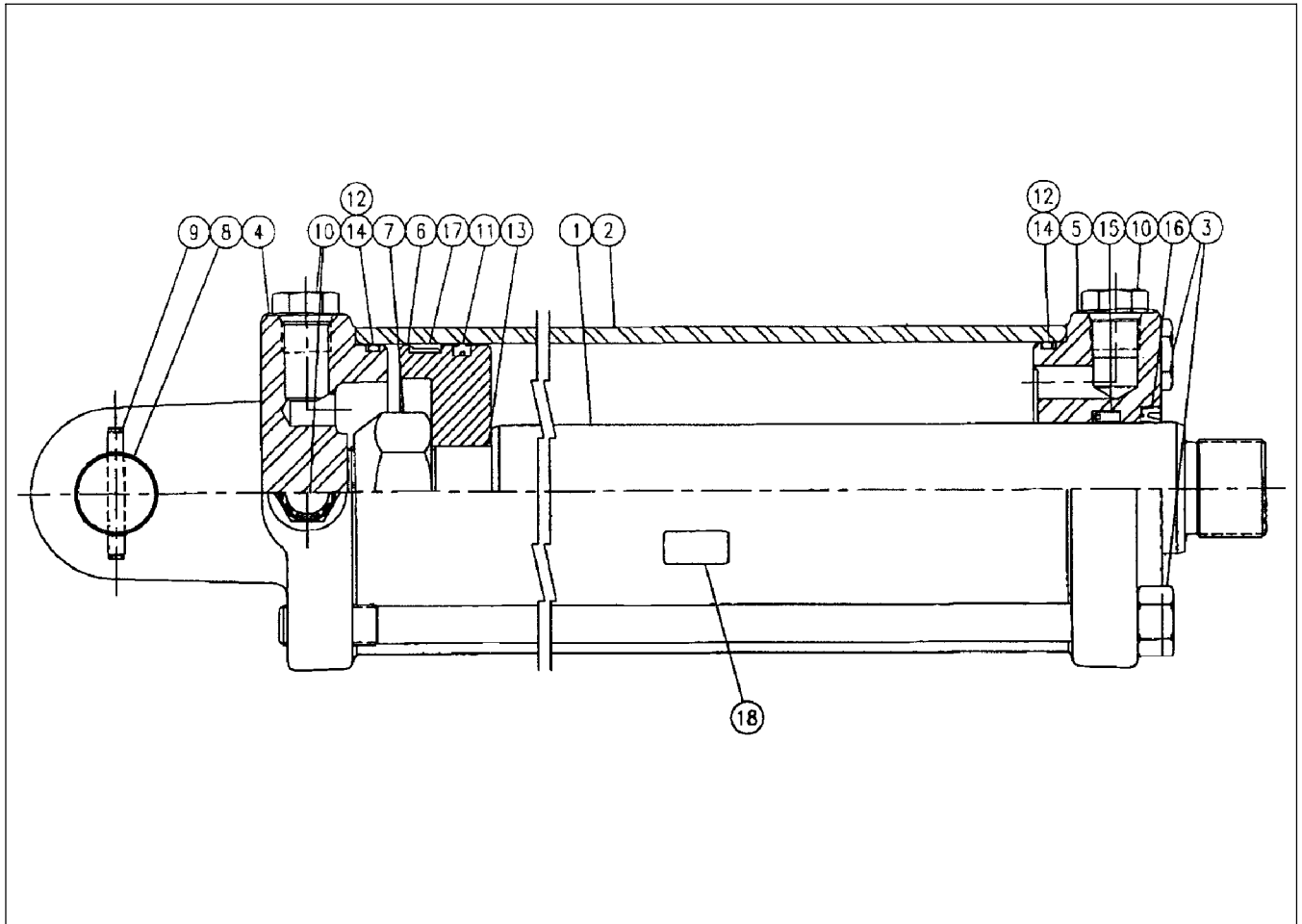

21-1027 4-1/2" X 32" PRINCE HYDRAULIC CYLINDER ASSEMBLY

9/02

Retracted - 41-3/8"

Stroke - 32"

Extended - 73-3/8"

Rod - 2"

Item	Part Number	Part Description	Qty.
1	21-2145	Piston Rod	1
2	21-2165	Tube	1
3	21-526	Tie Rod Assembly	4
4	21-887	Butt	1
5	21-888	Gland	1
6	21-2148	Piston	1
7	21-890	Lock Nut	1
8	21-859	Clevis Pin	1
9		1/4"DIA. x 2" Roll Pin	2
10	21-404	ORB Plug	3
11	★	Crown Seal	1
12	★	O-Ring	2
13	★	O-Ring	1
14	★	Back-Up Washer	2
15	★	U-Cup	1
16	★	Wiper	1
17	★	Bearing Ring	1
18	74-113	Decal - Cylinder Warning	1
	21-892	Seal Kit (Includes ★ Items)	

PRINCE HYDRAULIC CYLINDER

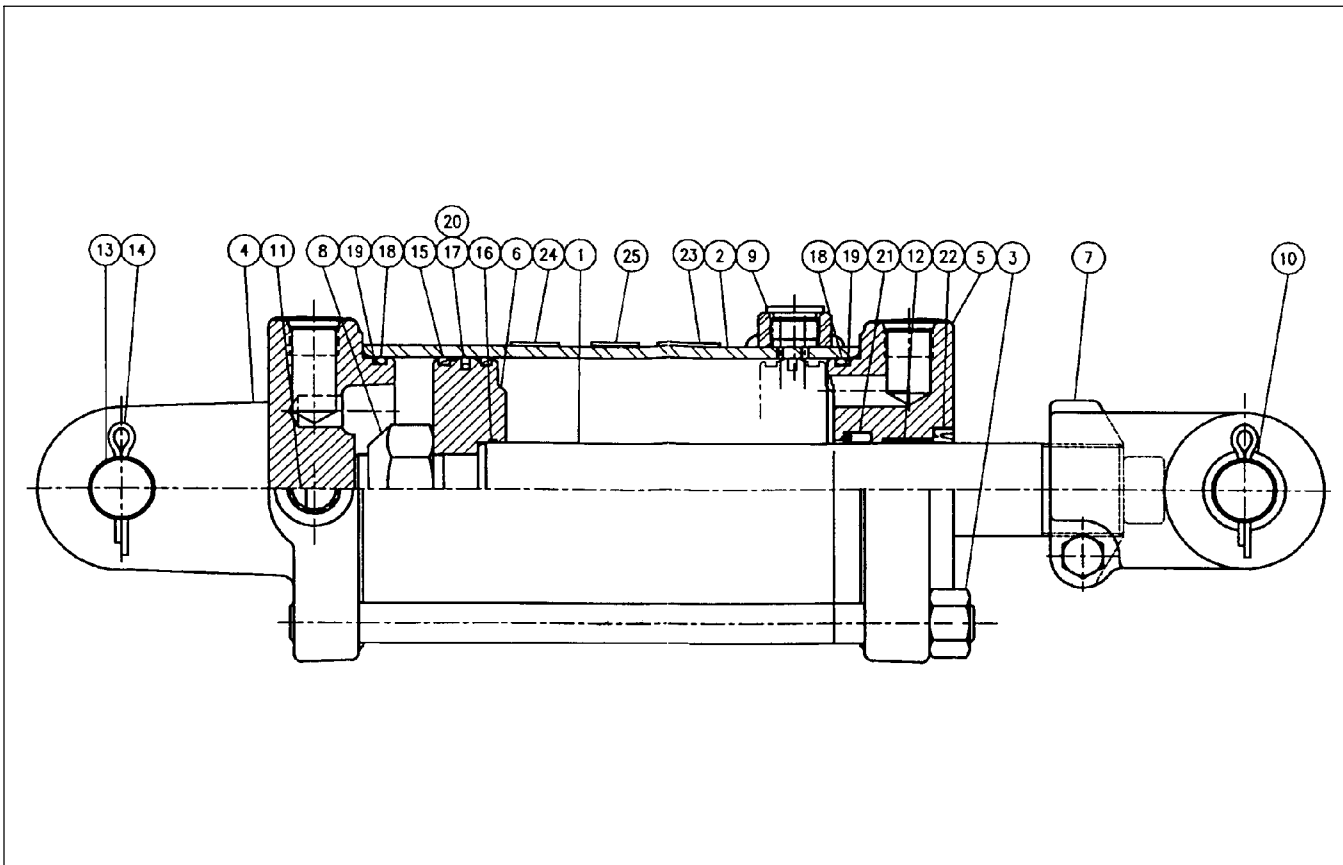

21-1008 4-1/4" X 10" PRINCE HYDRAULIC CYLINDER ASSEMBLY (Series) 9/02
Retracted - 22-1/4" Extended - 32-1/4" Stroke - 10" Rod Diameter - 1-1/2"

Item	Part Number	Part Description	Qty.
1	21-2062	Piston Rod	1
2	21-2065	Tube	1
3	21-381	Tie Rod Assembly	4
4	21-2072	Butt	1
5	21-2073	Gland	1
6	21-2074	Piston	1
7	21-2125	Clevis Assembly	1
8	21-819	Lock Nut	1
9	21-702	Port Plug	1
10	21-2127	Bushing	2
11	21-404	#8 SAE Plug	3
12	21-2069	Bushing	1
13	21-260	Clevis Pin	2
14		3/16" DIA. x 1-3/4" Cotter Pin	4
15	★	Bearing Ring	1
16	★	O-Ring	1
17	★	O-Ring	1
18	★	O-Ring	2
19	★	Back-Up Washer	2
20		Teflon Seal	1
21	★	U-Cup	1
22	★	Wiper	1
23	74-517	Seal Kit Decal	1
24	21-443	Series Caution Decal	1
25	74-113	Cylinder Warning Decal	1
	21-2060	Seal Kit (★ Items Included in Kit)	

PRINCE HYDRAULIC CYLINDER

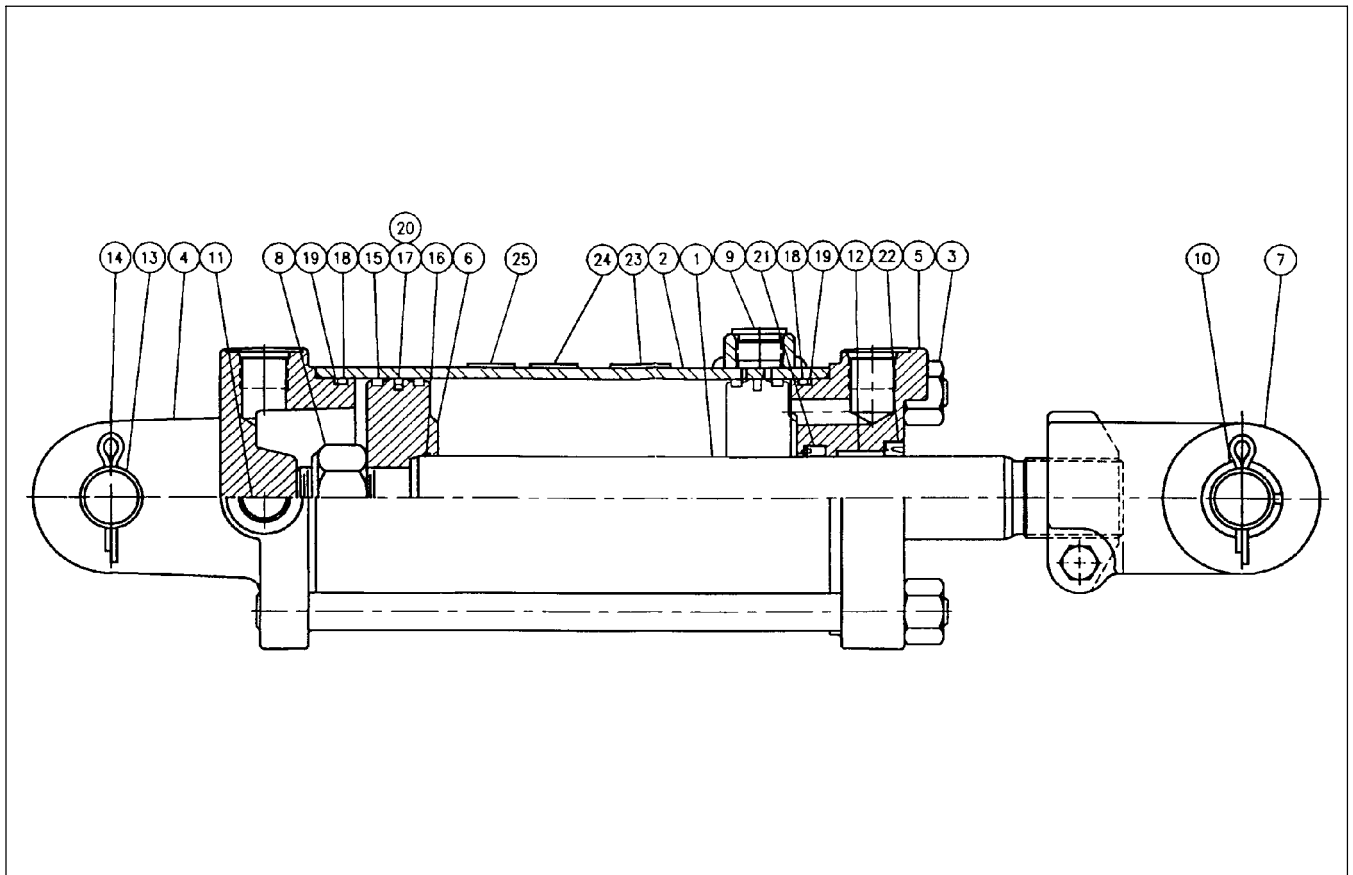

21-1007 4" X 10" PRINCE HYDRAULIC CYLINDER ASSEMBLY (Series) 6/04
Retracted - 22-1/4" Extended - 32-1/4" Stroke - 10" Rod Diameter - 1-3/8"

Item	Part Number	Part Description	Qty.
1	21-2061	Piston Rod	1
2	21-2063	Tube	1
3	21-381	Tie Rod Assembly	4
4	21-337	Butt	1
5	21-810	Gland	1
6	21-811	Piston	1
7	21-2126	Clevis Assembly	1
8	63-119	Lock Nut	1
9	21-702	ORB Plug	1
10	21-2127	Bushing	2
11	21-404	#8 SAE Plug	3
12	21-807	Bushing	1
13	21-260	Clevis Pin	2
14		3/16" DIA. x 1-3/4" Cotter Pin	4
15	★	Bearing Ring	1
16	★	O-Ring	1
17	★	O-Ring	1
18	★	O-Ring	2
19	★	Back-Up Washer	2
20	★	Teflon Seal	1
21	★	U-Cup	1
22	★	Wiper	1
23	74-516	Seal Kit Decal	1
24	21-443	Series Caution Decal	1
25	74-113	Cylinder Warning Decal	1
	21-2059	Seal Kit (★ Items Included in Kit)	

PRINCE HYDRAULIC CYLINDER

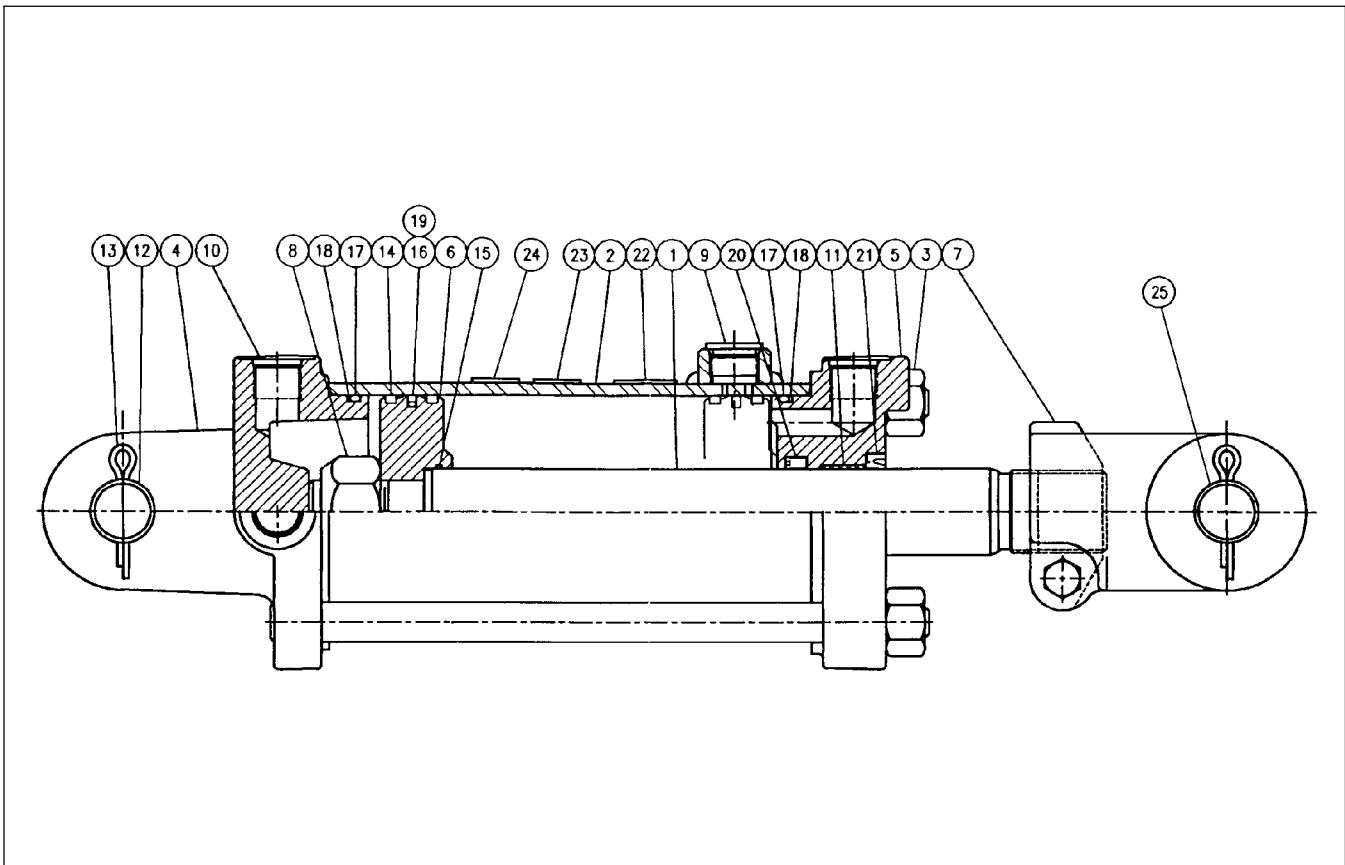

21-1006 3-3/4" X 10" PRINCE HYDRAULIC CYLINDER ASSEMBLY (Series) 6/04
Retracted - 22-1/4" Extended - 32-1/4" Stroke - 10" Rod Diameter - 1-3/8"

Item	Part Number	Part Description	Qty.
1	21-2061	Piston Rod	1
2	21-2064	Tube Assembly	1
3	21-381	Tie Rod Assembly	4
4	21-348	Butt	1
5	21-803	Gland	1
6	21-804	Piston	1
7	21-2126	Clevis Assembly	1
8	63-119	Lock Nut	1
9	21-702	Port Plug	1
10	21-404	#8 SAE Plug	3
11	21-807	Bushing	1
12	21-260	Clevis Pin	2
13		3/16" DIA. x 1-3/4" Cotter Pin	4
14	★	Bearing Ring	1
15	★	O-Ring	1
16	★	O-Ring	1
17	★	O-Ring	2
18	★	Back-Up Washer	2
19	★	Teflon Seal	1
20	★	U-Cup	1
21	★	Wiper	1
22	74-515	Seal Kit Decal	1
23	21-443	Series Caution Decal	1
24	74-113	Cylinder Warning Decal	1
25	21-2127	Bushing	2
	21-808	Seal Kit (★ Items Included in Kit)	

PRINCE HYDRAULIC CYLINDER

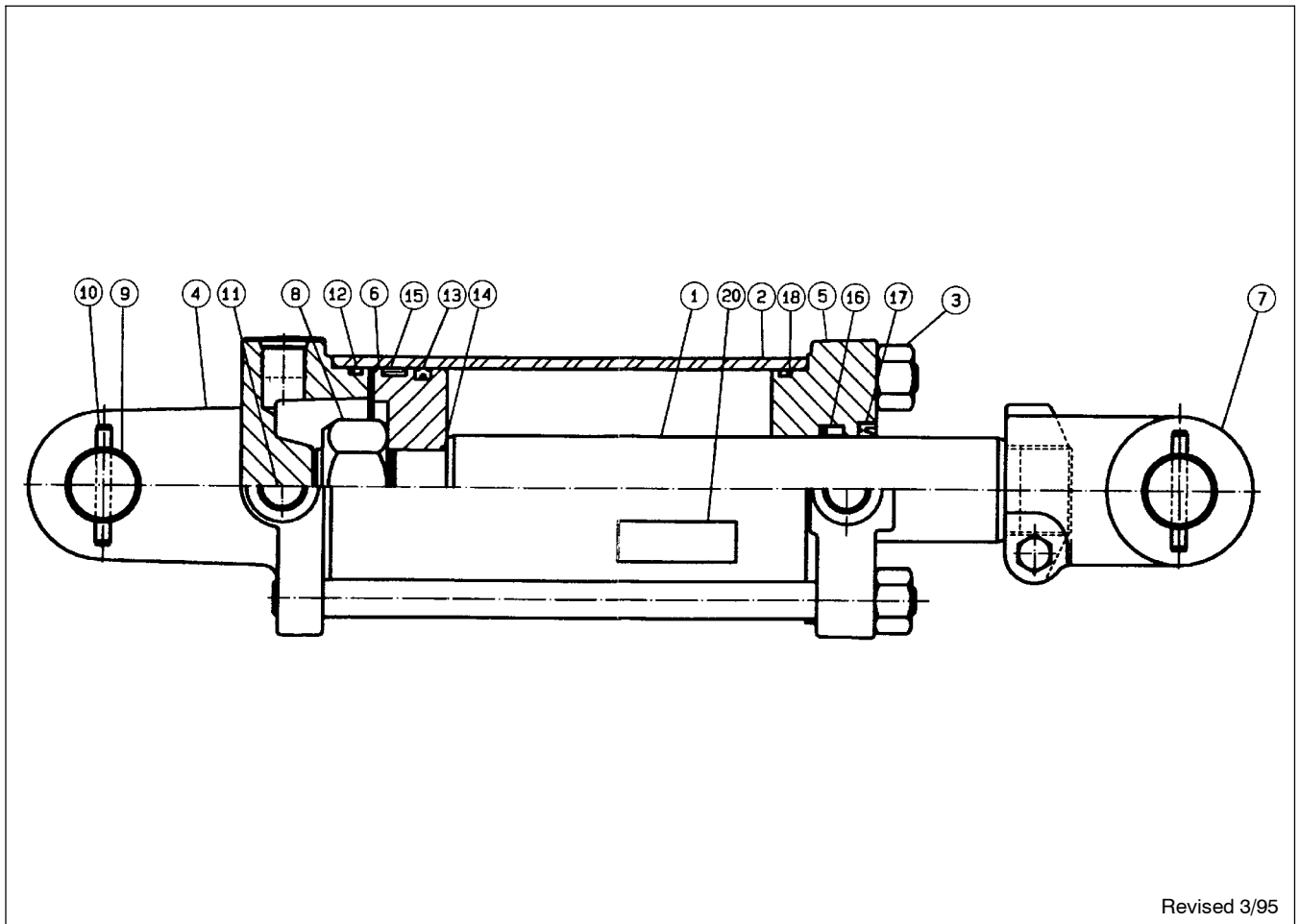

Revised 3/95

21-181 4" X 24" PRINCE HYDRAULIC CYLINDER ASSEMBLY

9/02

Retracted - 36-3/4"

Stroke - 24"

Extended - 60-3/4"

Rod - 1-3/4"

Item	Part Number	Part Description	Qty.
1	21-904	Piston Rod	1
2	21-222	Tube	1
3	21-2046	Tie Rod Assembly	4
4	21-738	Butt	1
5	21-878	Gland	1
6	21-879	Piston	1
7	21-507	Clevis Assembly	1
8	21-286	Lock Nut	1
9	21-859	Clevis Pin	2
10		1/4" DIA. x 2" Roll Pin	4
11	21-404	Plug	3
12	*	O-Ring	2
13	*	Crown Seal	1
14	*	O-Ring	1
15	*	Bearing Ring	1
16	*	U-Cup	1
17	*	Wiper	1
18	*	Back-Up Washer	1
19			
20	74-113	Cylinder Warning Decal	1
	• 21-857	Seal Kit (* Items Included in Kit)	
	• NOT INCLUDED IN HYDRAULIC CYLINDER ASSEMBLY		

PRINCE HYDRAULIC CYLINDER

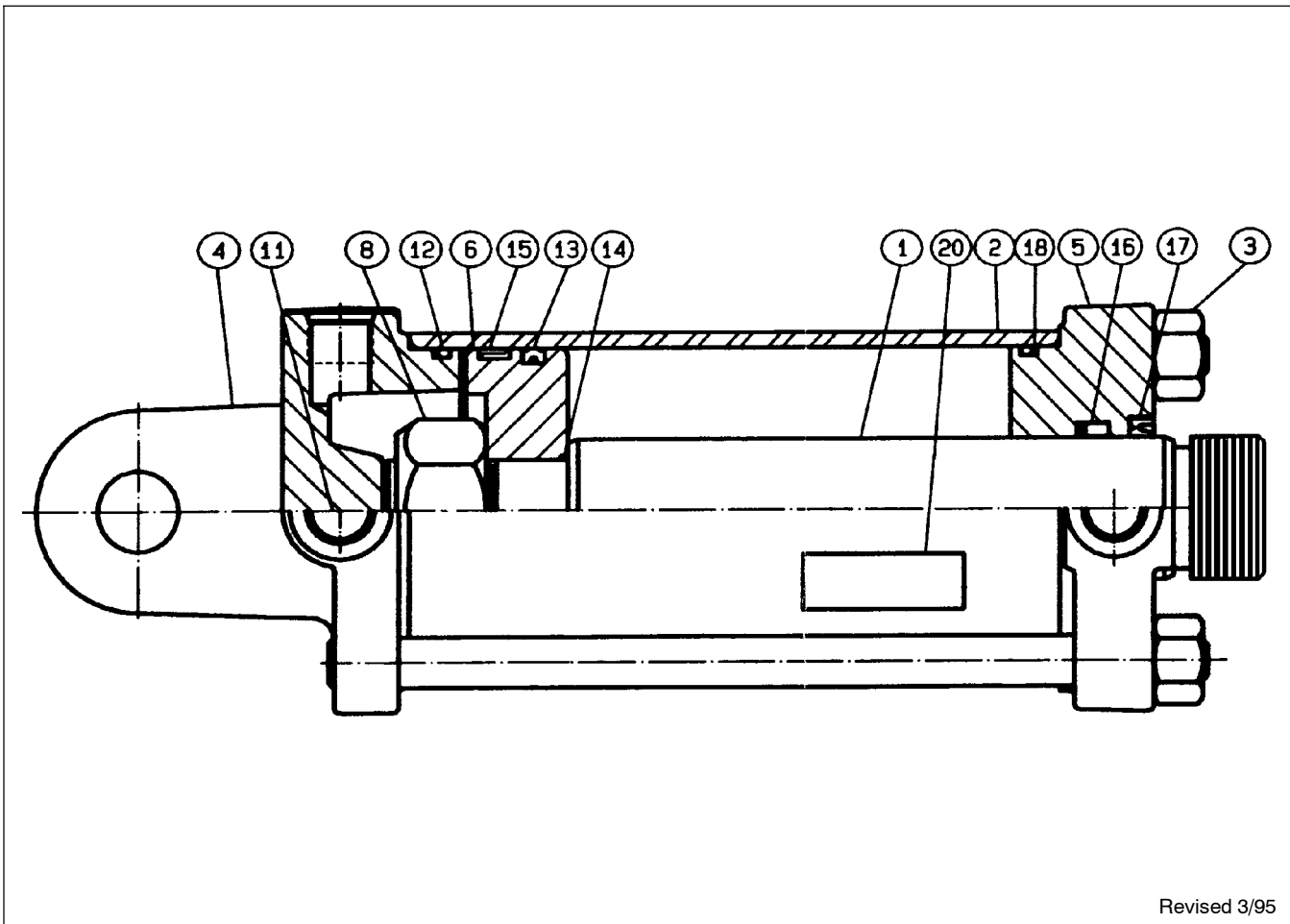

Revised 3/95

21-185 4" X 30" PRINCE HYDRAULIC CYLINDER ASSEMBLY 9/02
 Retracted - 38-3/8" Stroke - 30" Extended - 68-3/8" Rod - 1-3/4"

Item	Part Number	Part Description	Qty.
1	21-2013	Piston Rod	1
2	21-775	Tube	1
3	21-778	Tie Rod Assembly	4
4	21-337	Butt	1
5	21-878	Gland	1
6	21-879	Piston	1
7			
8	21-286	1-1/4NC Lock Nut	1
9			
10			
11	21-404	Plug	3
12	*	O-Ring	2
13	*	Crown Seal	1
14	*	O-Ring	1
15	*	Bearing Ring	1
16	*	U-Cup	1
17	*	Wiper	1
18	*	Back-Up Washer	2
19			
20	74-113	Cylinder Warning Decal	1
	• 21-857	Seal Kit (* Items Included in Kit)	
	• NOT INCLUDED IN HYDRAULIC CYLINDER ASSEMBLY		

PRINCE HYDRAULIC CYLINDER

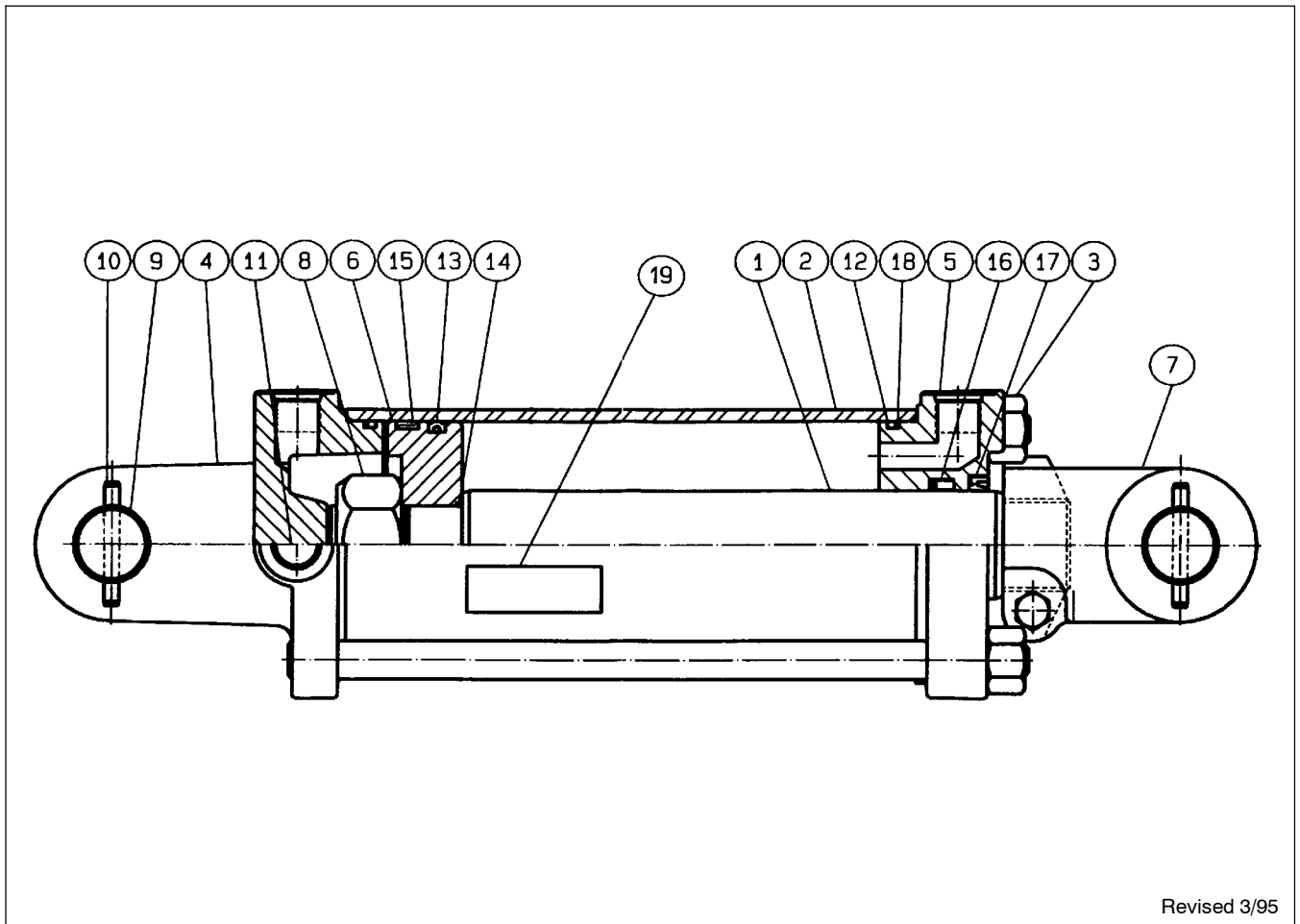

Revised 3/95

21-182 4" X 32" PRINCE HYDRAULIC CYLINDER ASSEMBLY

9/02

Retracted - 42-3/4"

Stroke - 32"

Extended - 74-3/4"

Rod - 1-3/4"

Item	Part Number	Part Description	Qty.
1	21-900	Piston Rod	1
2	21-266	Tube	1
3	21-526	Tie Rod Assembly	4
4	21-738	Butt	1
5	21-878	Gland	1
6	21-879	Piston	1
7	21-507	Clevis Assembly	1
8	21-286	Lock Nut	1
9	21-859	Clevis Pin	2
10		1/4" DIA. x 2" Roll Pin	4
11	21-404	Plug	3
12	*	O-Ring	2
13	*	Crown Seal	1
14	*	O-Ring	1
15	*	Bearing Ring	1
16	*	U-Cup	1
17	*	Wiper	1
18	*	Back-Up Washer	1
19	74-113	Cylinder Warning Decal	1
	• 21-857	Seal Kit (* Items Included in Kit)	
	• NOT INCLUDED IN HYDRAULIC CYLINDER ASSEMBLY		

PRINCE HYDRAULIC CYLINDER

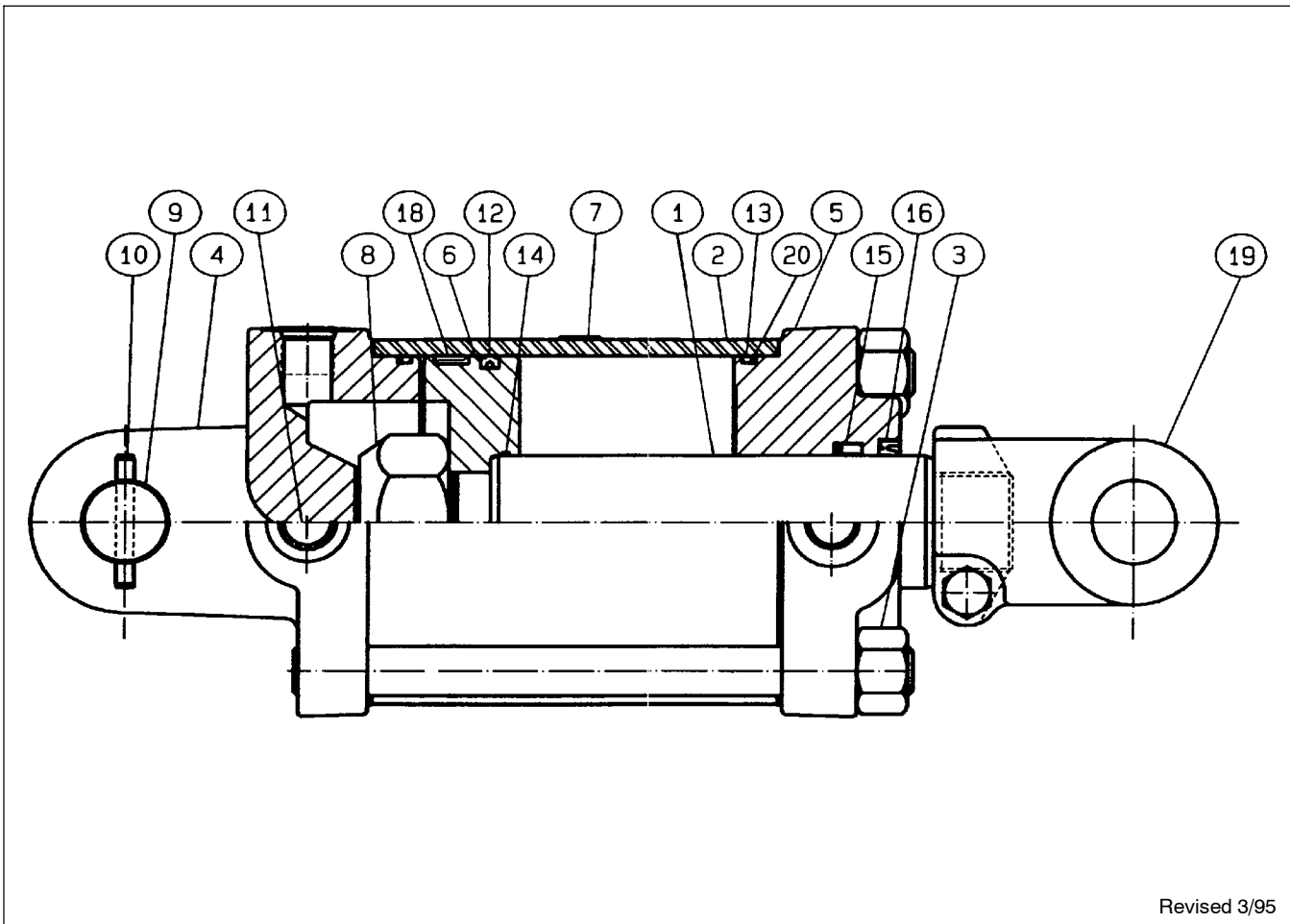

Revised 3/95

21-189 5" X 32" PRINCE HYDRAULIC CYLINDER ASSEMBLY

9/02

Retracted - 43-3/4"

Stroke - 32"

Extended - 75-3/4"

Rod - 2"

Item	Part Number		Qty.
1	21-917	Piston Rod	1
2	21-918	Tube	1
3	21-919	Tie Rod Assembly	4
4	21-868	Butt	1
5	21-869	Gland	1
6	21-870	Piston	1
7	74-113	Cylinder Warning Decal	1
8	21-871	Lock Nut	1
9	21-872	Clevis Pin	1
10		1/4" DIA. x 2" Roll Pin	2
11	21-404	Plug	3
12	*	Crown Seal	1
13	*	O-Ring	2
14	*	O-Ring	1
15	*	U-Cup	1
16	*	Wiper	1
17			
18	*	Bearing Ring	1
19	21-507	Clevis Assembly	1
20	*	Back-Up Washer	2
	● 21-858	Seal Kit (* Items Included in Kit)	
	● NOT INCLUDED IN HYDRAULIC CYLINDER ASSEMBLY		

PRINCE HYDRAULIC CYLINDER ASSEMBLY

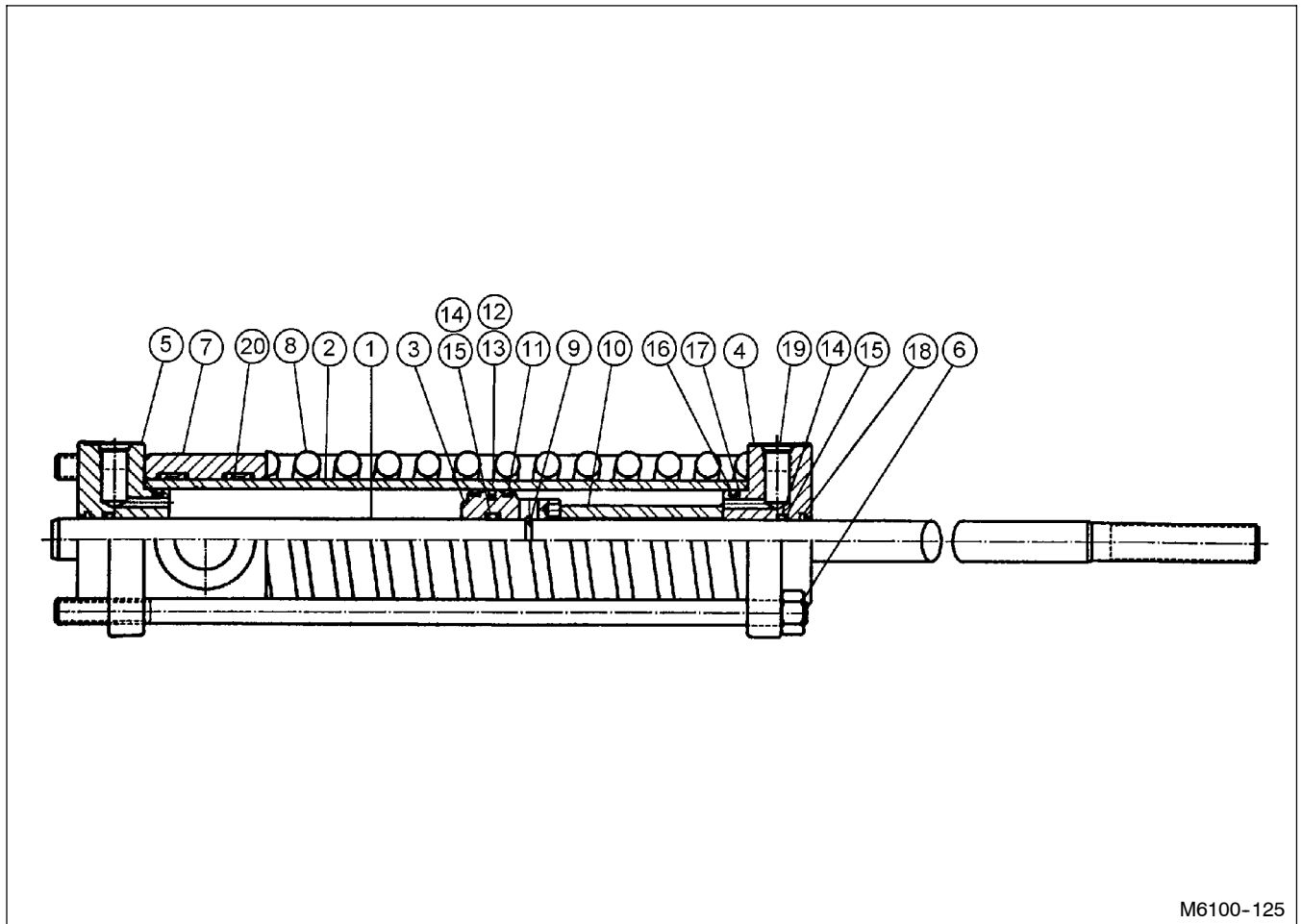

M6100-125

21-166 2" X 5-7/8" PRINCE HYDRAULIC CYLINDER ASSEMBLY

9/02

Stroke - 5-7/8"

Rod - 13/16"

Item	Part Number	Part Description	Qty.
1	21-865	Piston Rod	1
2	21-833	Tube	1
3			
4	21-835	Gland	1
5	21-836	Gland	1
6	21-837	Tie Rod Assembly	4
7	6100-0-1	Trunnion Casting	1
8	76-201	Spring	1
9			
10	21-841	Spacer	1
11	*	Bearing Ring	2
12	*	Teflon Seal	1
13	*	O-Ring	1
14	*	O-Ring	2
15	*	Back-Up Washer	2
16	*	O-Ring	2
17	*	Back-Up Washer	2
18	*	Wiper	2
19	21-848	ORB Plug	2
20	21-855	Bearing Ring	2
	• 21-821	Seal Kit (* Items Included in Kit)	
	•	NOT INCLUDED IN HYDRAULIC CYLINDER ASSEMBLY	

CYLINDER SUPPORT ASSEMBLY

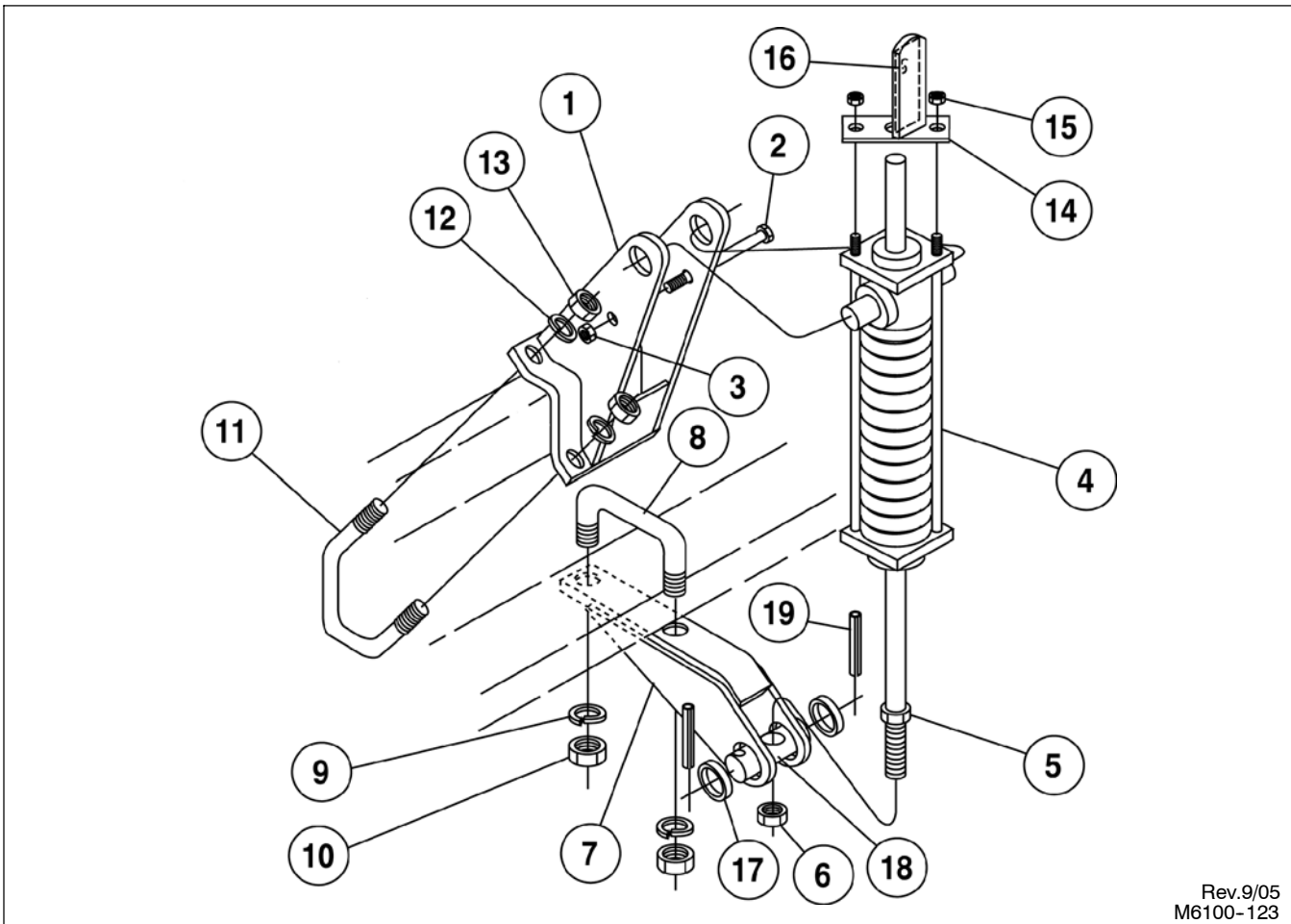

Rev.9/05
M6100-123

FOR MODELS - ALL

9/05

Item	Part Number	Part Description	Qty.
	6127-210-0B	Cylinder Support Assembly	1
1	6127-212-0A	Cylinder Support Weldment	1
2	62-562	3/8NC x 4-1/2" GD. 5 Cap Screw	1
3	63-134	3/8NC Self Locking Nut	1
4	21-166	Hydraulic Cylinder Assembly	1
5	63-230	3/4NF Hex Jam Nut	1
6	63-234	3/4NF Hex Lock Nut	1
7	6127-94-0A	Arm Weldment	1
8	★ 61-143	3/4" DIA. U-Bolt	1
9	★ 64-112	3/4" STD. Lock Washer	2
10	★ 63-112	3/4NC Hex Nut	2
11	★ 61-228	5/8" DIA. U-Bolt	2
12	★ 64-109	5/8" STD. Lock Washer	4
13	★ 63-109	5/8NC Hex Nut	4
14	★ 6100-208-0	Depth Gauge Weldment	1
15	★ 63-235	1/2NF Hex Jam Nut	2
16	★ 74-391	Decal - Depth Gauge	1
17	53-142	Bushing (Included in Item 7 Arm Weldment)	2
18	6127-210-1	Trunnion	1
19	60-608	1/4" DIA. x 2-1/2" Roll Pin	2
★ NOT PART OF CYLINDER SUPPORT ASSEMBLY			
● USED FOR MODELS TL 6200 42 AND 45 SEE PAGE P83 FOR LOCATION			

DISC GANG HYDRAULIC HOSE & FITTINGS

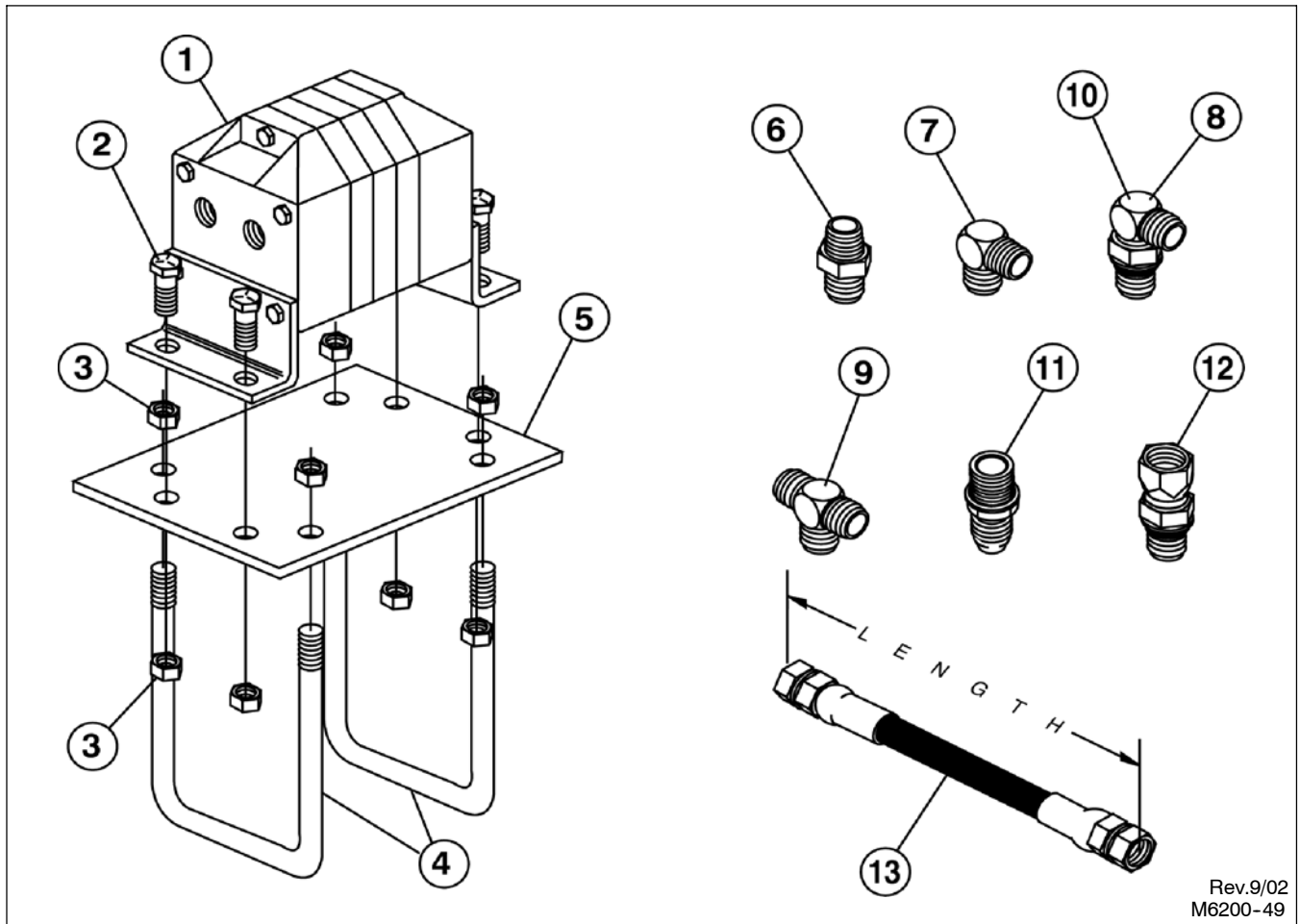

Rev.9/02
M6200-49

FOR MODELS - With Hydraulic Disc Gangs

9/03

Item	Part Number	Part Description	Qty.	Item	Part Number	Part Description	Qty.
1	25-2271	Hydraulic Flow Divider	1		24-508R	1/4" x 30" JIC Hose Assembly	
2	62-108	3/8NC x 1" GD. 5 Cap Screw	4		24-509R	1/4" x 200" JIC Hose Assembly	
3	63-134	3/8NC Nylon-Top Lock Nut	8		24-511R	1/4" x 100" JIC Hose Assembly	
4	61-245	3/8" DIA. U-Bolt	2		24-512R	1/4" x 208" JIC Hose Assembly	
5	6136-200-1	Flow Divider Mount	1		24-513R	1/4" x 36" JIC Hose Assembly	
6	25-392	1/2"JIC-3/8NPT Hydraulic Fitting	1		24-514R	1/4" x 22" JIC Hose Assembly	
7	25-393	1/2JIC-3/8NPT (Male) 90° Fitting	1		24-515R	1/4" x 172" JIC Hose Assembly	
8	25-385	9/16"O-Ring (Male) - 1/2"JIC (Male) 90° Fitting	1		24-516R	1/4" x 64" JIC Hose Assembly	
9	25-394	37° Flare 1/2"JIC (Male) Tee	1		24-517R	1/4" x 88" JIC Hose Assembly	
10	25-391	9/16"O-Ring (Male)-1/2"JIC (Male) 90° Restrictor Fitting	1		24-518R	1/4" x 264" JIC Hose Assembly	
11	25-400	9/16" (Male) O-Ring - 1/2 (Male) JIC Hydraulic Fitting	4		24-519R	1/4" x 124" JIC Hose Assembly	
12	25-593	Swivel Adapter	1		24-520R	1/4" x 168" JIC Hose Assembly	
13	24-503R	1/4" x 36" JIC Hose Assembly			24-521R	1/4" x 16" JIC Hose Assembly	
	24-527R	1/4" x 42" JIC Hose Assembly			24-522R	1/4" x 46" JIC Hose Assembly	
	24-504R	1/4" x 240" JIC Hose Assembly			• 4881-74-0	3/8" x 96" Hose & Grip - Red/Gray	
	24-505R	1/4" x 72" JIC Hose Assembly			• 4881-75-0	3/8" x 96" Hose & Grip - Gray/Gray	
	24-506R	1/4" x 184" JIC Hose Assembly			<ul style="list-style-type: none"> For Models TL 6200 36, 42 & 45 See page P64 for detailed parts listing 		
	24-507R	1/4" x 92"(Male) JIC-NPT Hose					

PACKER HITCH ASSEMBLY

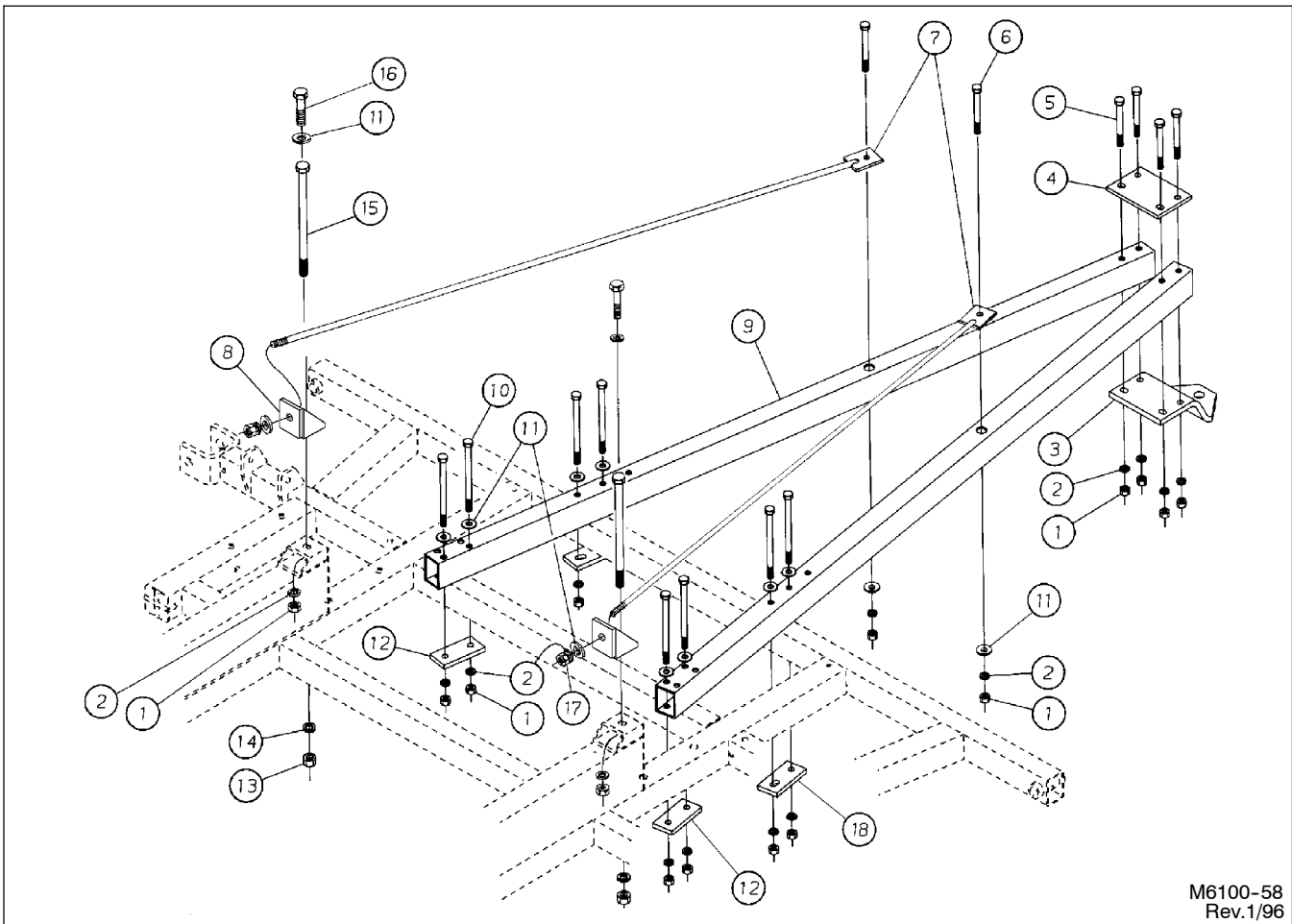

M6100-58
Rev.1/96

FOR MODELS - ALL

9/02

Item	Part Number	Part Description	Qty.
1	●★■ 63-112	3/4NC Hex Nut	Spec.
2	●★■ 64-112	3/4" STD. Lock Washer	Spec.
3	●★■ 6112-401-0	Drop Plate	1
4	●★■ 6112-400-1	Bolt Plate	1
5	●★■ 62-213	3/4NC x 6-1/2" GD. 5 Cap Screw	4
6	★■ 62-207	3/4NC x 5-1/2" GD. 5 Cap Screw	2
7	★■ 6127-412-0	Hitch Rod Weldment	2
8	★■ 6127-411-0	Angle Mount	2
9	●★■ 6112-410-0A	Hitch Box Weldment	2
10	●★■ 62-224	3/4NC x 10" Machine Bolt	8
11	●★■ 64-113	3/4" STD. Flat Washer	Spec.
12	●★■ 3127-571-1	Bolt Plate	2
13	■ 63-117	1NC Hex Nut	2
14	■ 64-118	1" STD. Lock Washer	2
15	■ 62-606	1NC x 16" Machine Bolt	2
16	★ 62-195	3/4NC x 2-1/2" GD. 5 Cap Screw	2
17	★■ 63-236	3/4NF Nut	2
18	●★■ 6112-400-3	Bolt Plate	2
<ul style="list-style-type: none"> ● Used for Models TL 6200 - 9, 12, 15 ★ Used for Models TL 6200 - 18, 21, 24 ■ Used for Models TL 6200 - 27, 31, 36, 42, 45 			

MODEL TL 6200 - 09

HYDRAULIC DISC GANG ASSEMBLY

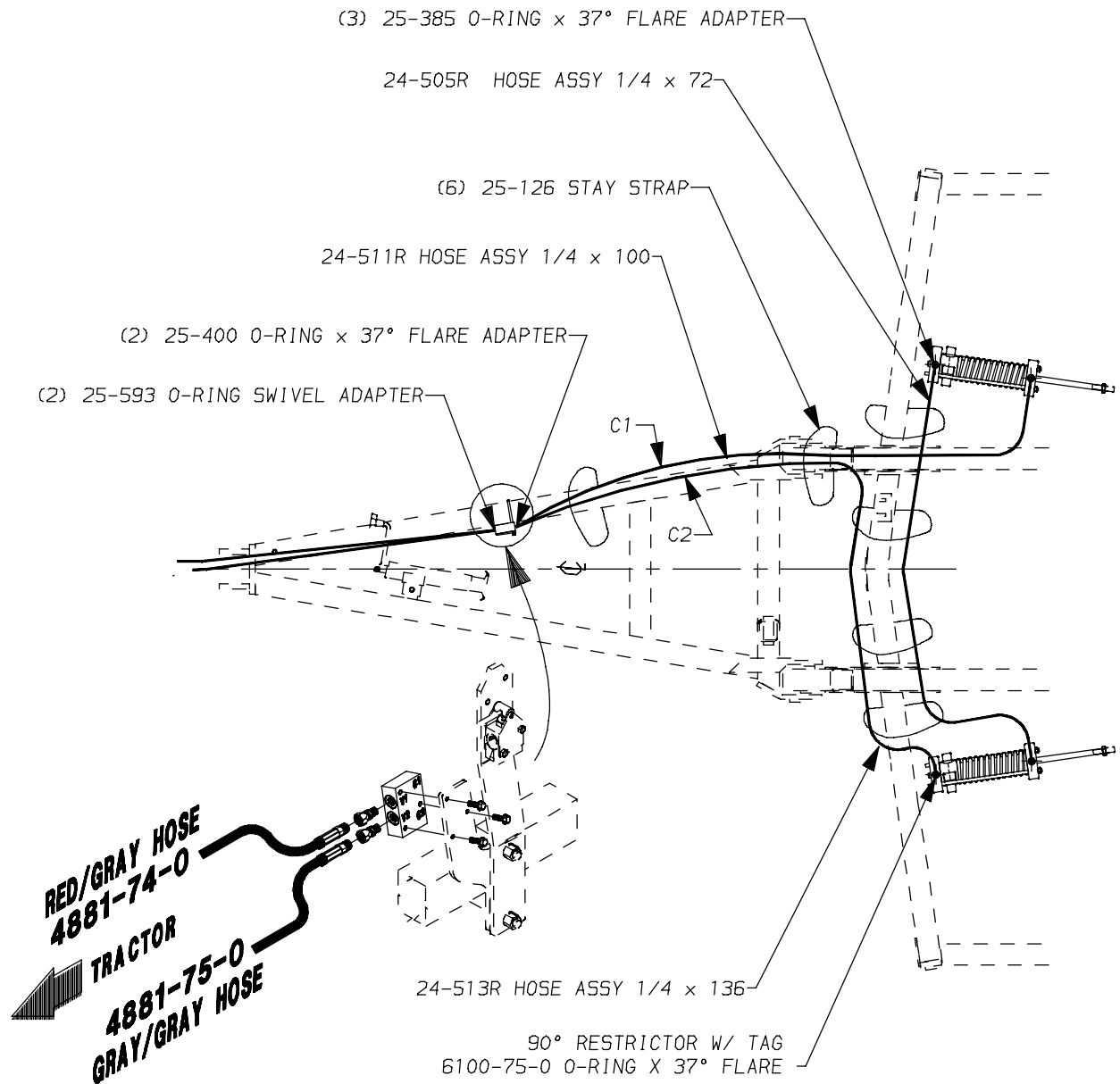

MODEL TL 6200 - 12 & 15
 HYDRAULIC DISC GANG ASSEMBLY

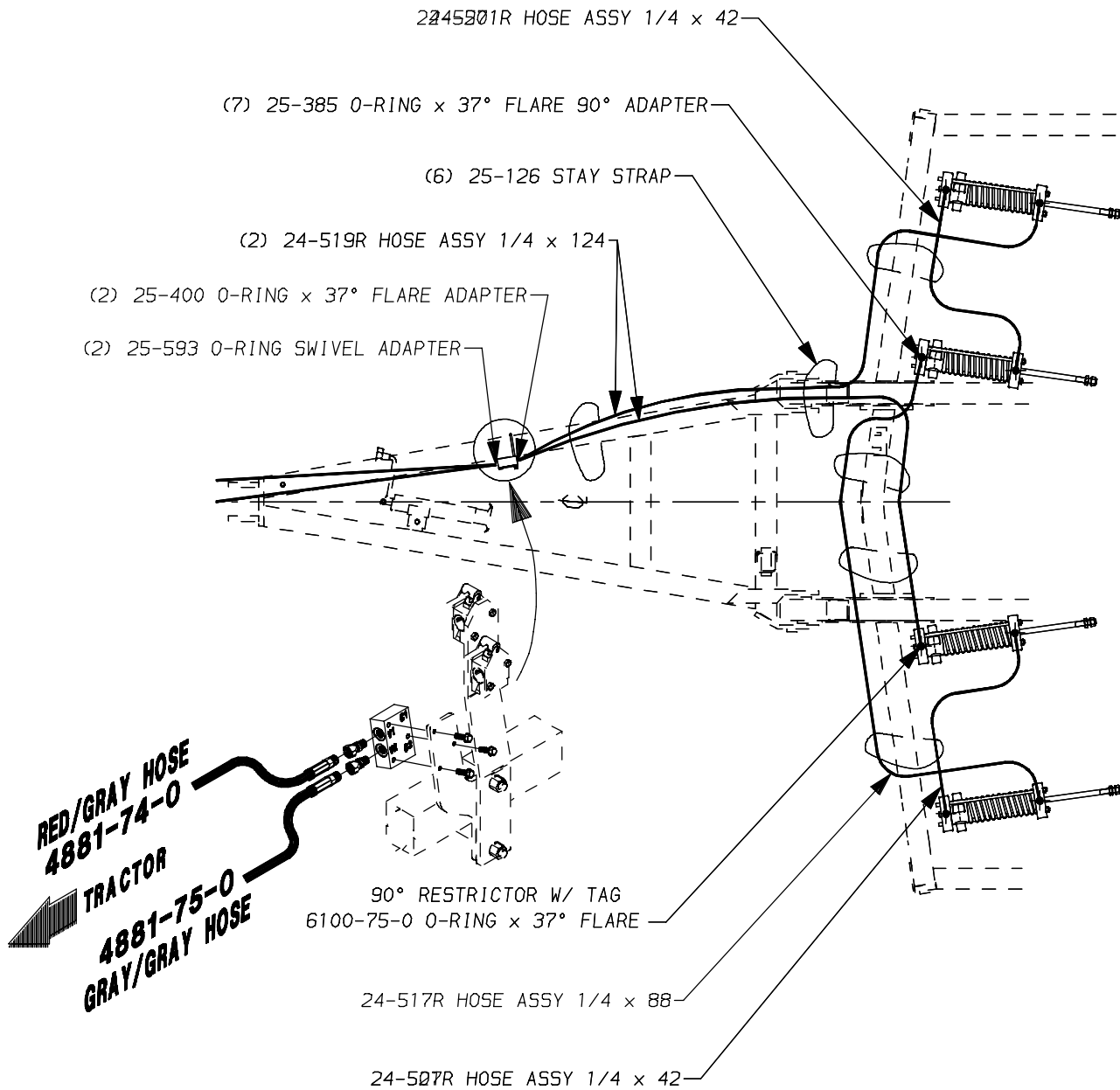

REV. 9/03
 M6200-52

MODEL TL 6200 - 18 & 21
 HYDRAULIC DISC GANG ASSEMBLY

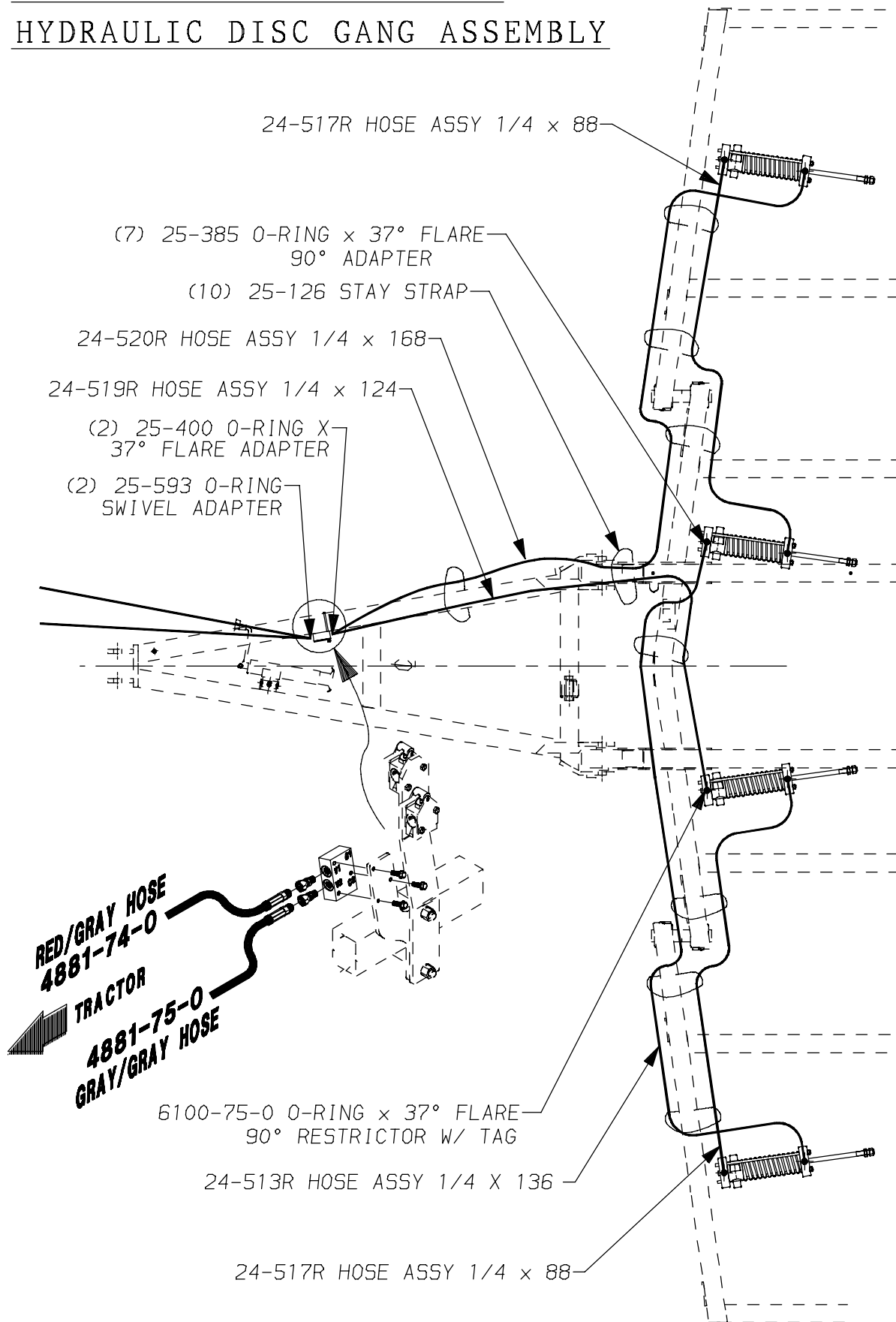

REV. 9/02
 M6200-53

MODEL TL 6200 - 24

HYDRAULIC DISC GANG ASSEMBLY

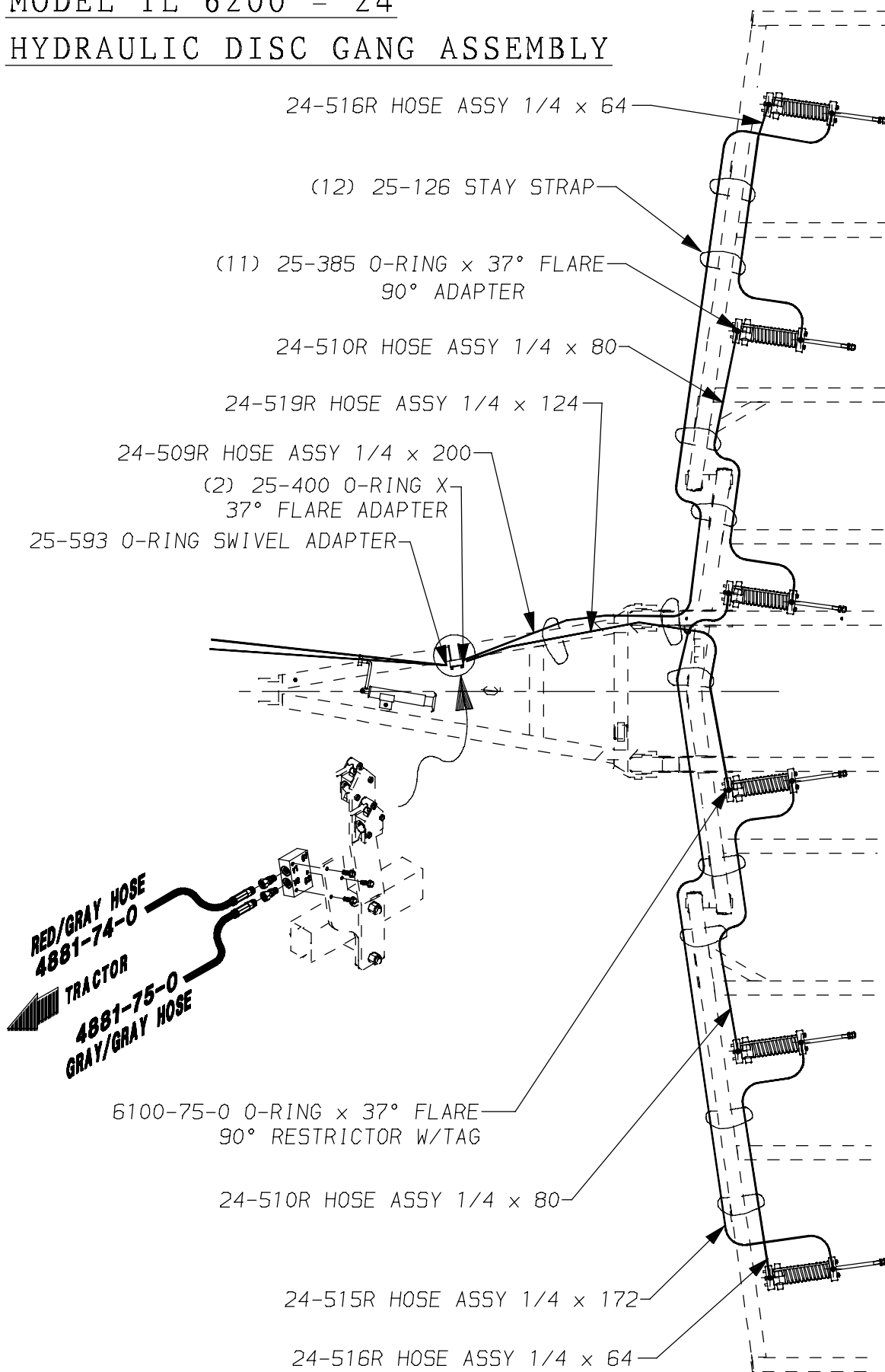

REV. 9/02
M6200-54

MODEL TL 6200 - 27 & 31 HYDRAULIC DISC GANG ASSEMBLY

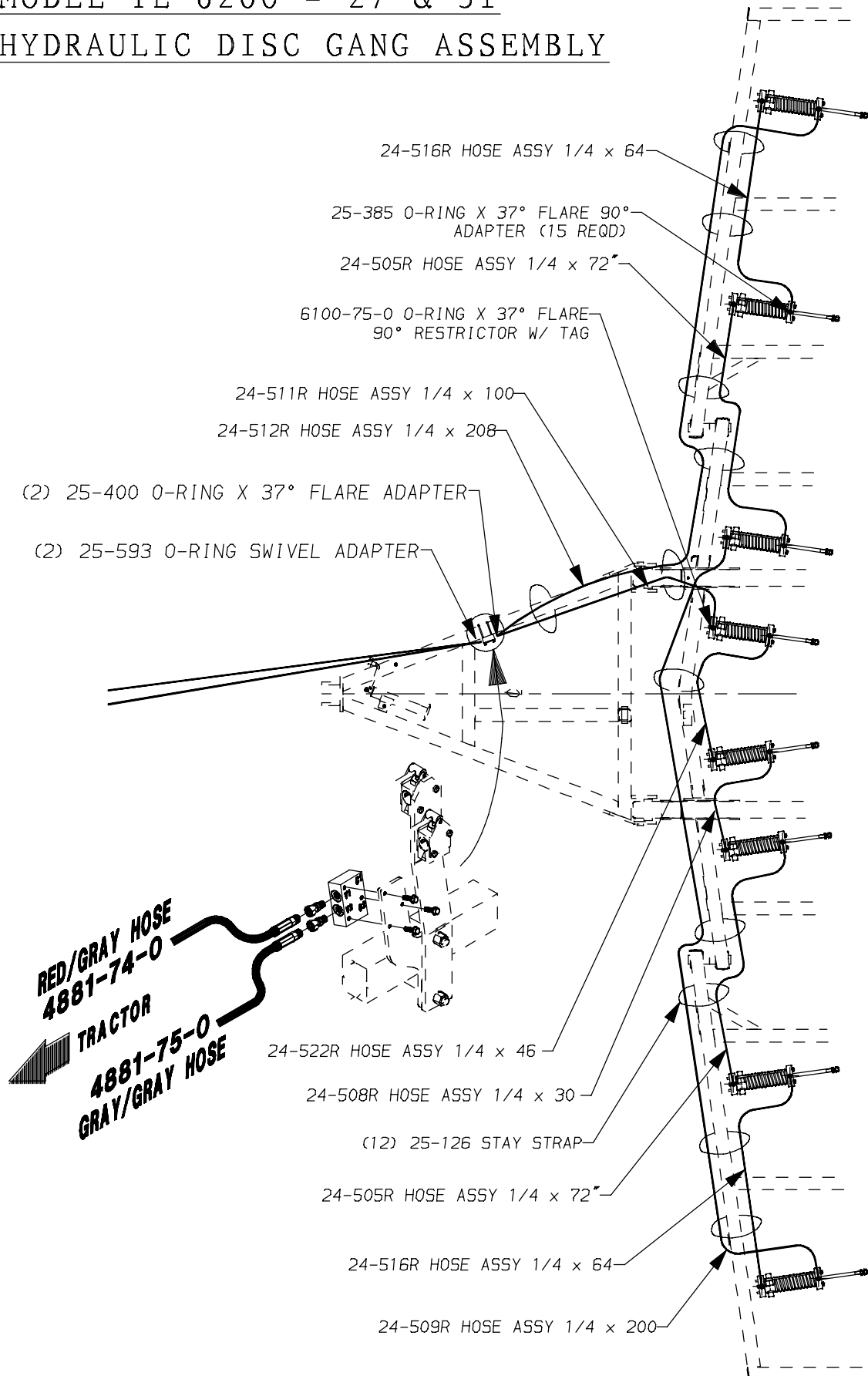

REV. 9/02
M6200-55

MODEL TL 6200 - 36

HYDRAULIC DISC GANG ASSEMBLY

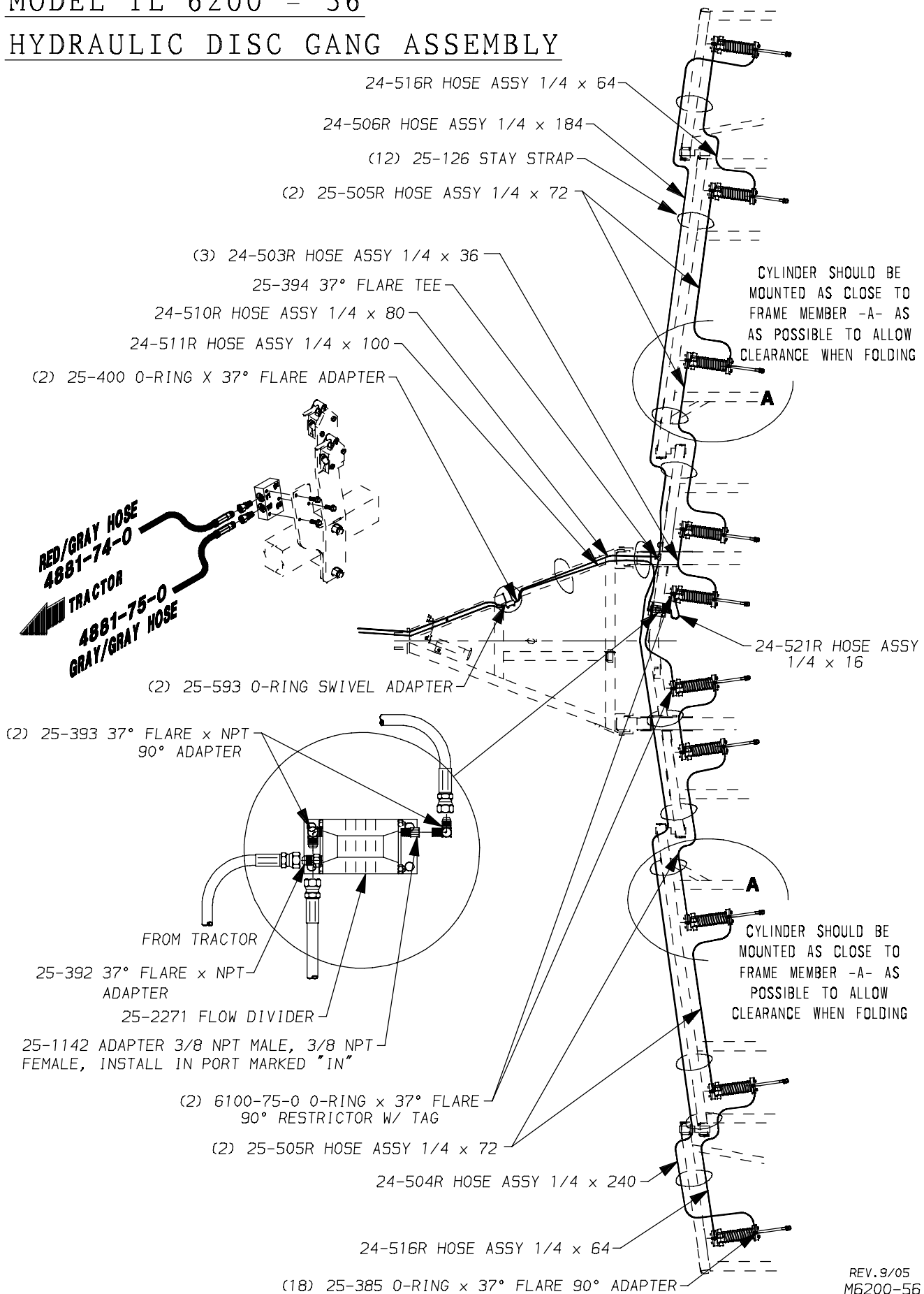

REV. 9/05
M6200-56

MODEL TL 6200 - 42 & 45 HYDRAULIC DISC GANG ASSEMBLY

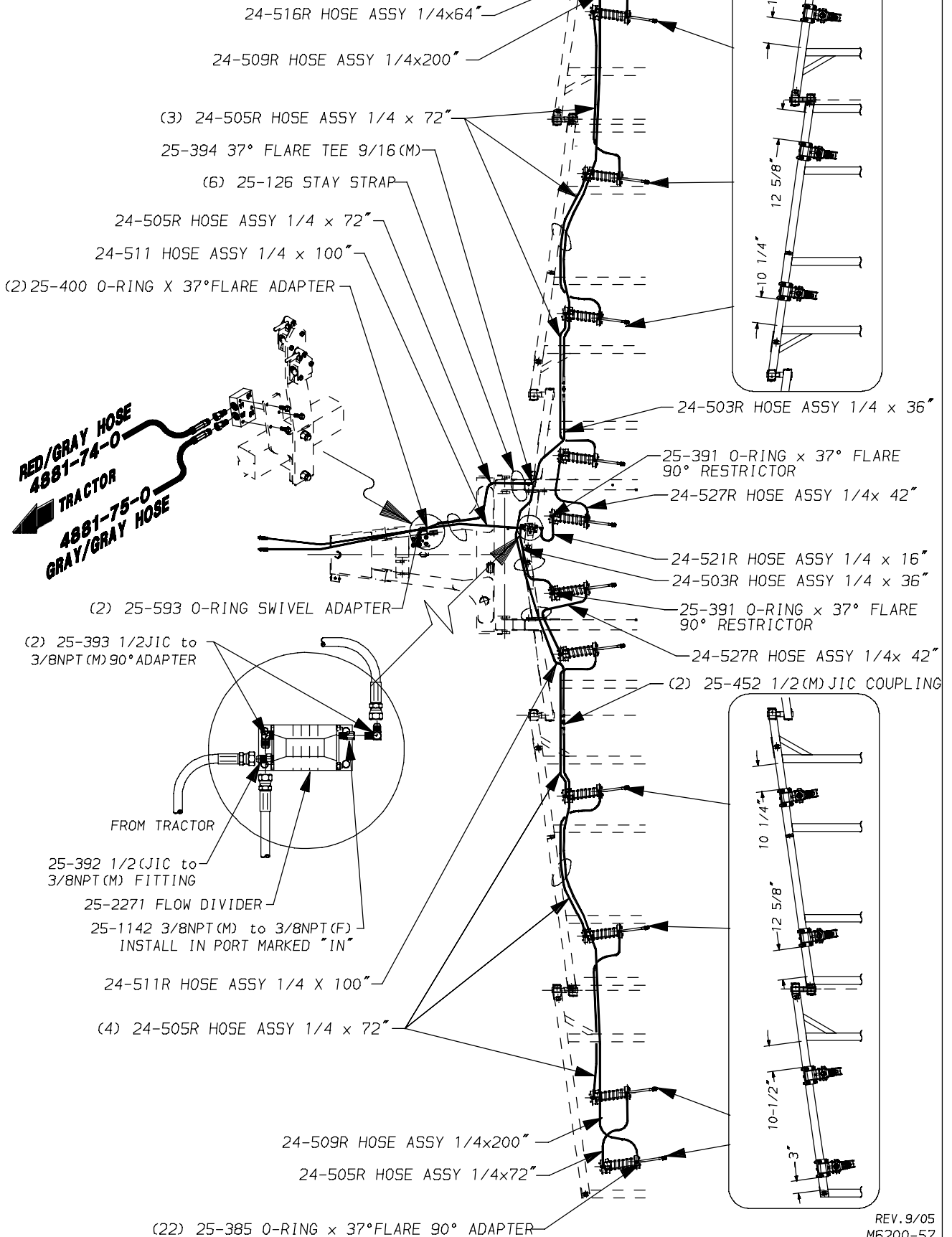

REV. 9/05
M6200-57

DECALS & REFLECTORS

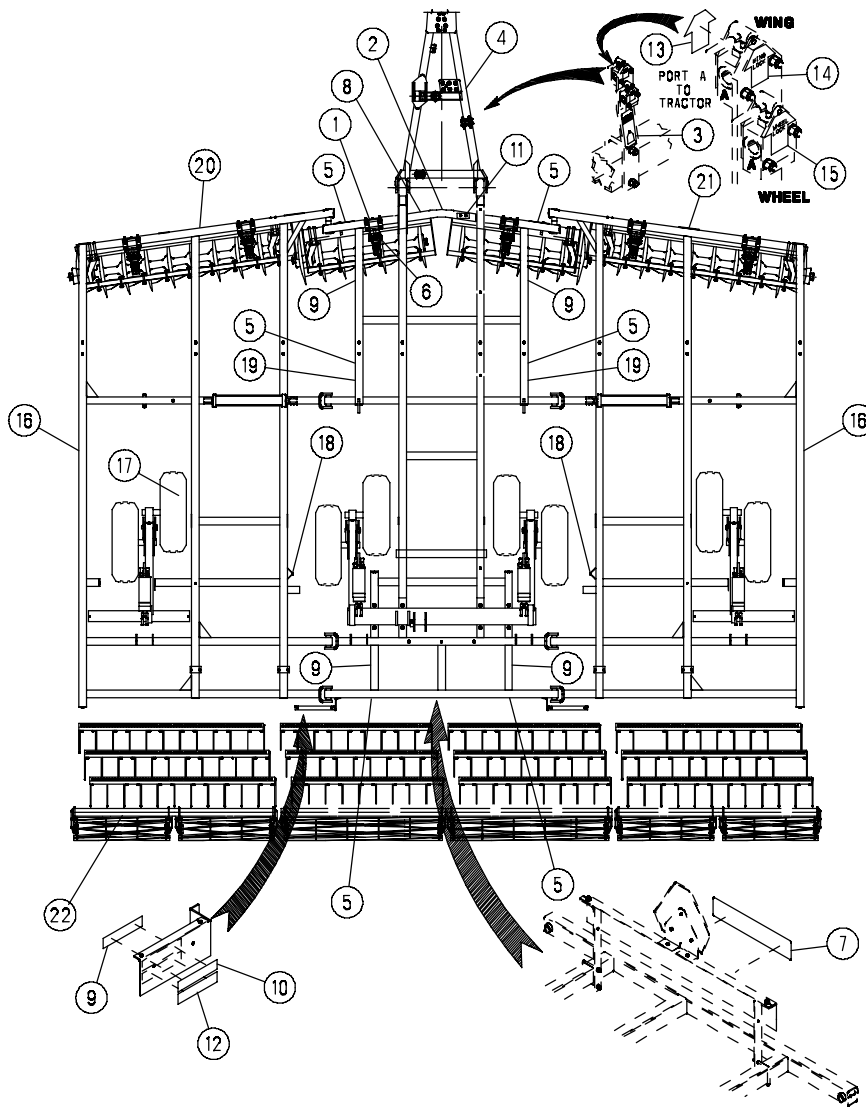

REV 9/02
M6200-59

FOR MODELS - TL 6200 - 9, 12, 15, 18, 21, 27, 31

9/07

Item	Part Number	Part Description	Qty.
1	74-121	Decal - Width / Height	1
2	74-570	Decal - Warning (Universal)	1
3	74-393	Decal - WARNING Transport Lock	1
4	74-276	Decal - Warning - Hydraulic Safety	1
5	74-102	Decal - Stand Clear of Wing	6
6	74-391	Decal - Depth Gauge	1
7	74-602	Decal - KRAUSE (6" x 48")	1
8	74-115	Name Plate	1
9	74-577	Reflective Tape - Yellow	8
10	74-575	Reflective Tape - Red	2
11	74-348	Pinch Point Decal	1
12	74-576	Fluorescent Tape - Orange	2
13	74-571	Decal - Wing Transport Lock, Rt	1
14	74-572	Decal - Wing Transport Lock, Lt	1
15	74-574	Decal - Wheel Transport Lock, Lt	1
16	74-604	Decal - KRAUSE (4" x 24")	2
17	74-109	Decal - Wheel Bolts	8
18	74-387	Decal - Maintenance Lock	2
19	74-648	Decal - Trademark (3-1/2")	2
20	74-151	Landsman Decal	1
21	74-608	Decal - TL 6200	1
22	74-110	Decal - Krause	Spec.

DECALS & REFLECTORS

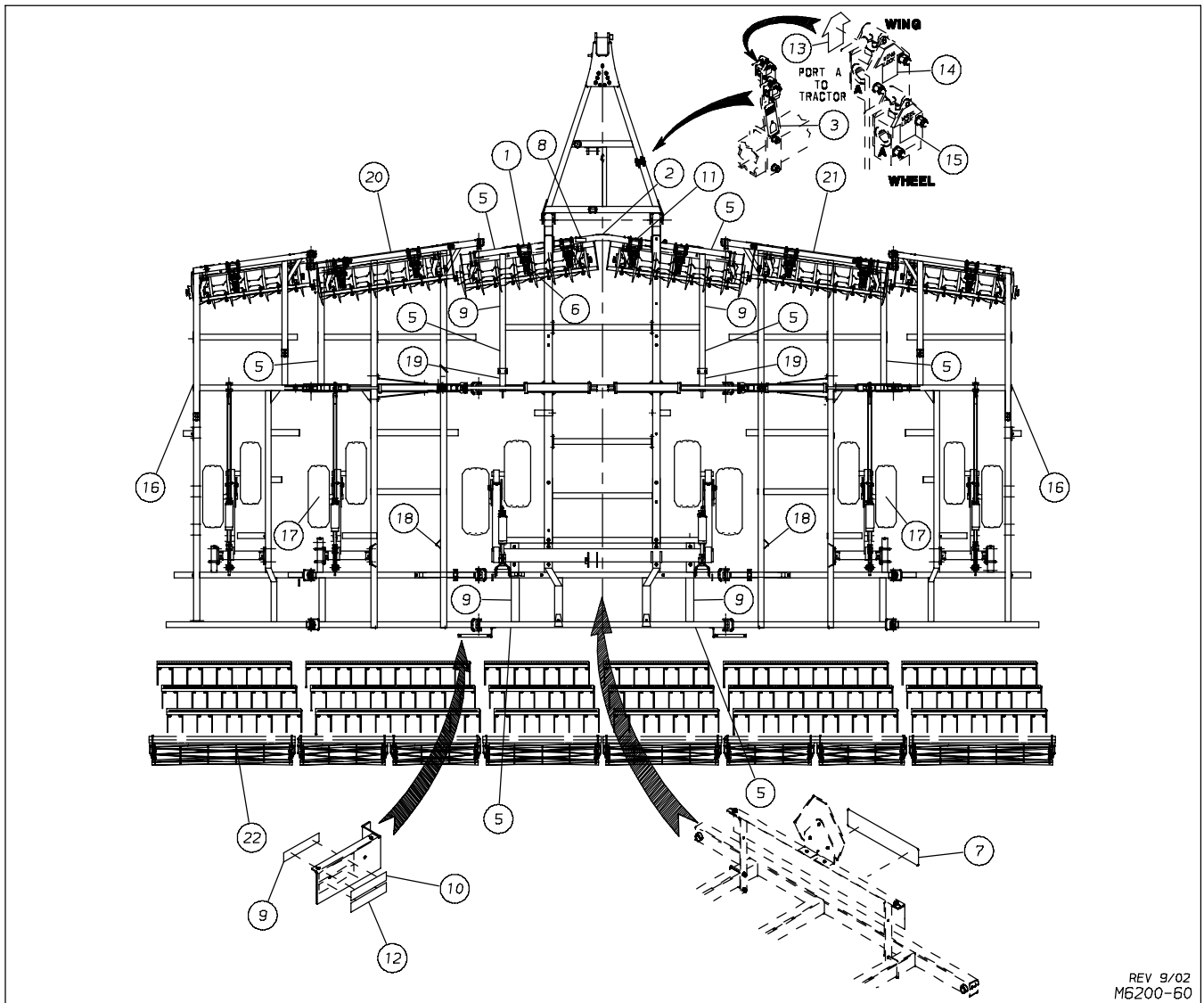

REV 9/02
M6200-60

FOR MODELS - TL 6200 - 36, 42 & 45

9/07

Item	Part Number	Part Description	Qty.
1	74-121	Decal - Width / Height	1
2	74-570	Decal - Warning (Universal)	1
3	74-393	Decal - WARNING Transport Lock	1
4	74-276	Decal - Warning - Hydraulic Safety	1
5	74-102	Decal - Stand Clear of Wing	6
6	74-391	Decal - Depth Gauge	1
7	74-602	Decal - KRAUSE (6" x 48")	1
8	74-115	Name Plate	1
9	74-577	Reflective Tape - Yellow	8
10	74-575	Reflective Tape - Red	2
11	74-348	Pinch Point Decal	1
12	74-576	Fluorescent Tape - Orange	2
13	74-571	Decal - Wing Transport Lock, Rt	1
14	74-572	Decal - Wing Transport Lock, Lt	1
15	74-574	Decal - Wheel Transport Lock, Lt	1
16	74-604	Decal - KRAUSE (4" x 24")	2
17	74-109	Decal - Wheel Bolts	8
18	74-387	Decal - Maintenance Lock	2
19	74-648	Decal - Trademark (3-1/2")	2
20	74-151	Landsman Decal	1
21	74-608	Decal - TL 6200	1
22	74-110	Decal - Krause	Spec.

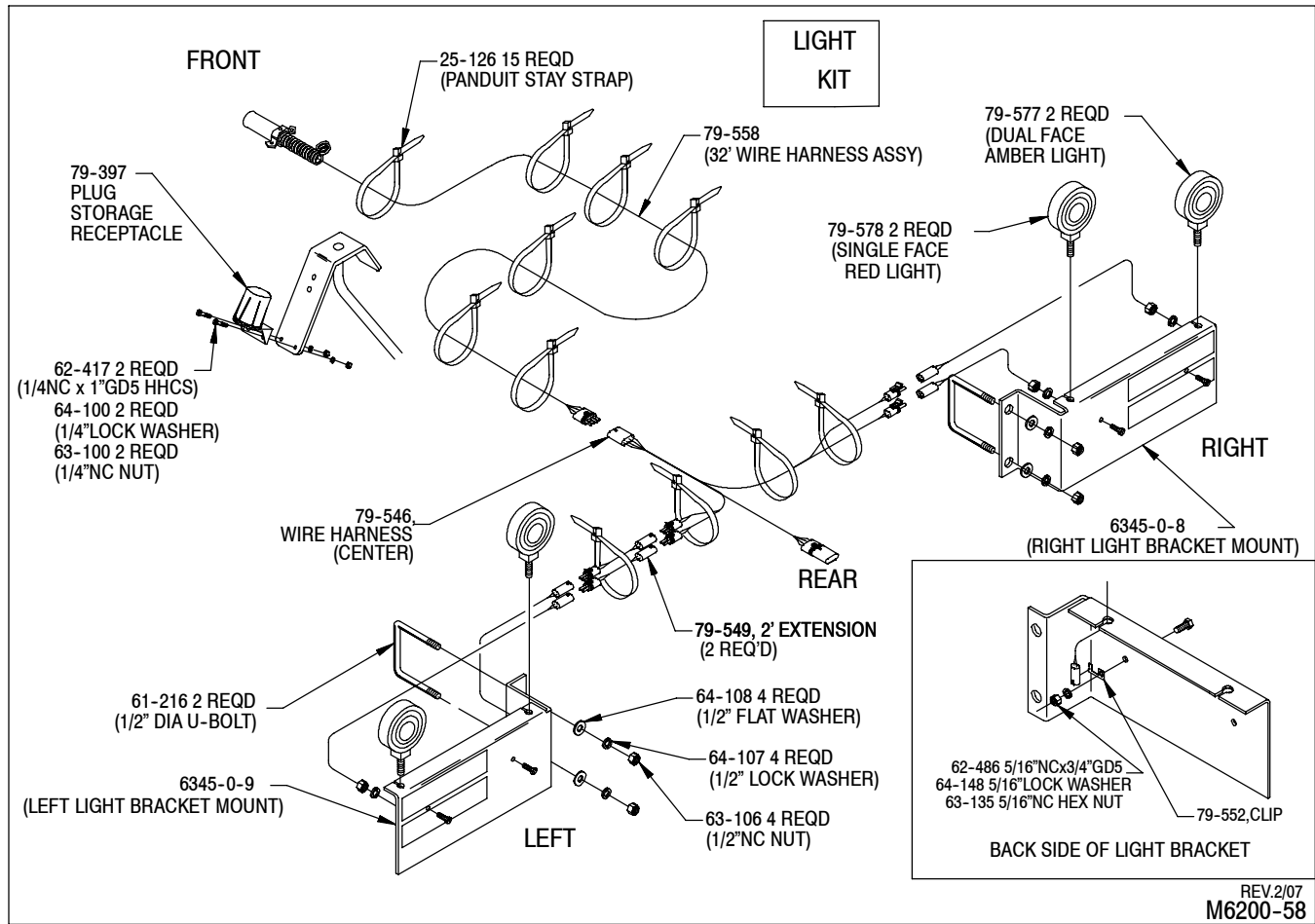

REAR RECEPTACLE PARTS

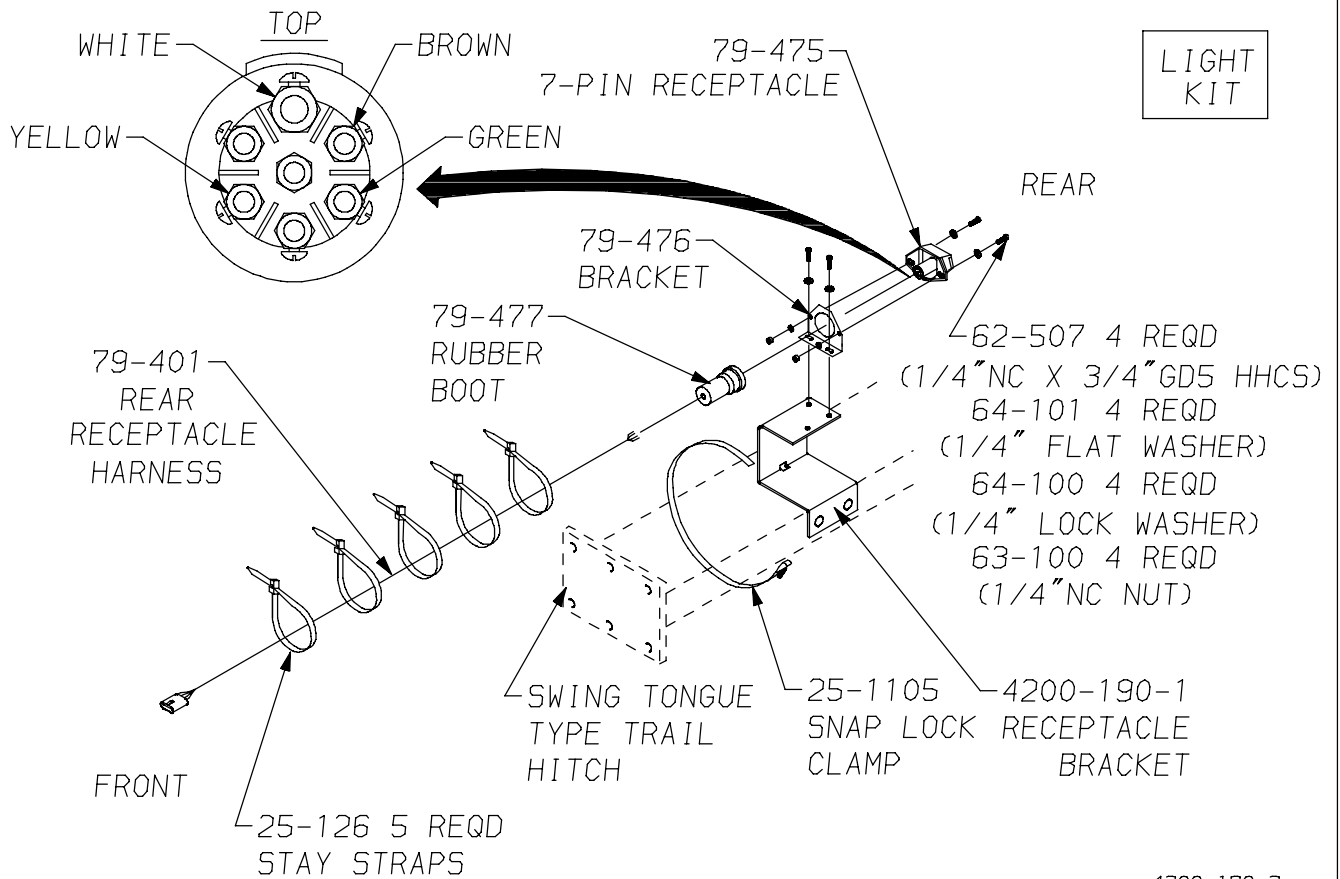
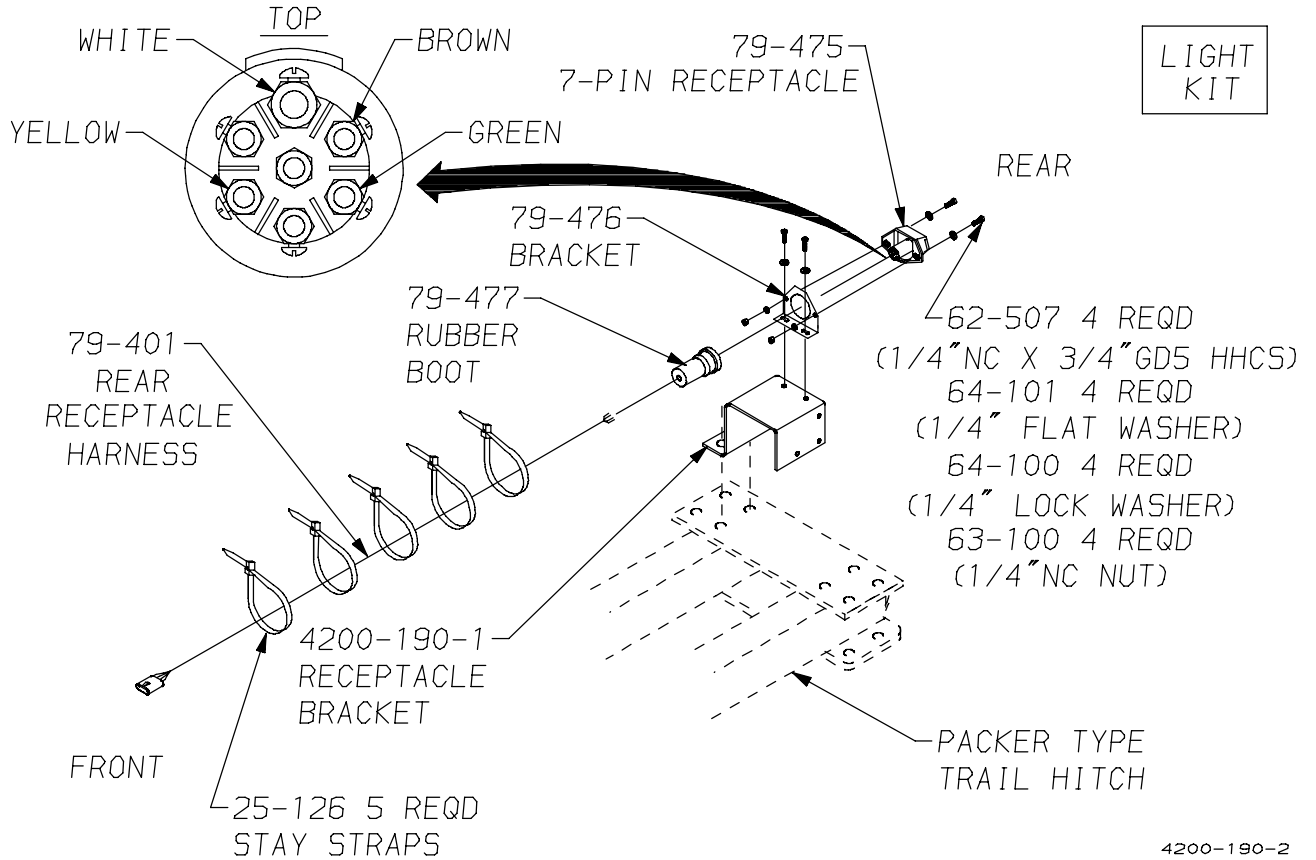

This page intentionally left blank.

ASSEMBLY SECTION

THE FOLLOWING SECTION ILLUSTRATES A GENERAL METHOD FOR THE ASSEMBLY OF THIS SERIES KRAUSE TILLAGE TOOL. YOU MUST KNOW THE MODEL NUMBER OF THE UNIT BEING ASSEMBLED WHENEVER MAKING REFERENCE TO THIS SECTION. THE FOLLOWING PICTURES AND DRAWINGS WILL SHOW BOLTS, PINS, NUTS AND ETC., WITH THE DESCRIPTIVE SIZE AND LENGTHS IN THE ACCOMPANYING PARAGRAPH AND A PARTS LISTING REFERENCE PAGE NUMBER. IF ANY DIFFICULTY SHOULD BE ENCOUNTERED DURING THE ASSEMBLY, RECHECK THE ILLUSTRATIONS, ASSEMBLY STEPS AND PARTS LIST DRAWINGS.

PROPER BOLT USE

DO NOT use these values if a different torque value or tightening procedure is given for a specific application. Torque values listed are for general use only. Check tightness of fasteners periodically.

Shear bolts are designed to fail under predetermined loads. Always replace shear bolts with identical grade.

Fasteners should be replaced with the same or higher grade. If higher grade fasteners are used, these should only be tightened to the strength of the original.

Tighten plastic insert or crimped steel-type lock nuts to approximately 110 percent of the dry torque shown in the chart, applied to the nut, not to the bolt head. Tighten toothed or serrated-type lock nuts to the full torque value.

NOTE: "Lubricated" means coated with a lubricant such as engine oil, or fasteners with phosphate and oil coatings. "Dry" means plain or zinc plated without any lubrication. **Tighten lubricated bolts to approximately 80% of dry bolts.**

BOLT SIZE	WRENCH SIZE	BLACK OR PLATED BOLTS		
		GRADE 2	GRADE 5	GRADE 8
3/8"	9/16"	20	33	45
7/16"	5/8"	32	52	70
1/2"	3/4"	50	80	105
5/8"	15/16"	100	150	210
3/4"	1-1/8"	160	260	375
7/8"	1-5/16"	175	415	600
1"	1-1/2"	250	625	880
1-1/8"	1-11/16"	375	850	1400
1-1/4"	1-7/8"	530	1100	1765
1-1/2"	2-1/4"	930	1400	2540

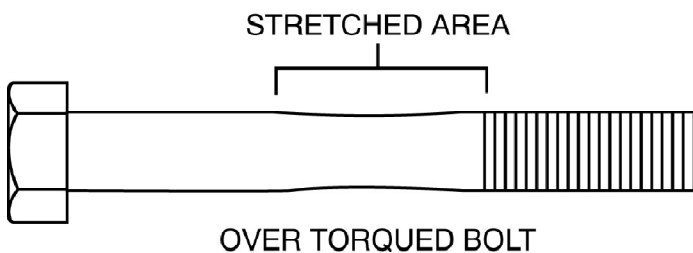

SAE
GRADE 2

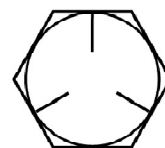

SAE
GRADE 5

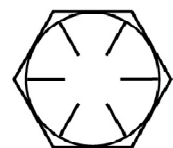

SAE
GRADE 8

ASSEMBLY INSTRUCTIONS

STUDY NAMES AND LOCATIONS OF THE PARTS AND FAMILIARIZE YOURSELF WITH THE LANDSMAN BEFORE STARTING THE ASSEMBLY. READING THE STEP-BY-STEP INSTRUCTIONS THAT FOLLOW WILL BE HELPFUL.

SAFETY



READ ALL OF THE SAFETY NOTATIONS IN THE ASSEMBLY INSTRUCTIONS FOR YOUR PROTECTION. ACCIDENTS CAN BE PREVENTED BY RECOGNIZING THE CAUSE OF AN ACCIDENT BEFORE IT CAN HAPPEN.

ASSEMBLY AREA

Select an area for assembly that will be large enough to accommodate the completed implement. The surface of the work area should be as level as possible. Leave room in front of the Landsman to hook up to a tractor to charge the hydraulic system and fold the unit. Use the proper hand tools to insure proper bolt tightness. Refer to the page titled "Proper Bolt Use" for the recommended torque values for different size bolts. Weights of major parts are MAIN FRAMES - 1,600 LBS.; MAIN ROCKER SHAFT - 410 LBS., TONGUE - 330 LBS.; therefore, stands will have to support the combined weight of 2,500 Lbs. Make sure that the chains and handling equipment are adequate for this weight.

PART LOCATIONS

FRONT - the front of the frame can be determined by the location of the name plate that has been attached to the front frame member.

RIGHT and LEFT sides can be established by standing behind the frame and looking toward the front, or the direction of travel.

TOP - To be sure that the frame is right side up, position the front hitch members of the frame pointing **down**.

ASSEMBLY STEPS

Assemble the Landsman following the steps shown in this section. Each step for part attachment is reflected by a matching number on the accompanying drawing or photograph.

Example:

Mount Bearing Arm **12** to each end of the Reel Assembly. Assemble with 1/2NC x 1-1/2" GD5 Carriage Bolts, Lock Washers and Hex Nuts. Make sure bearing grease zerk is in cut-out provided.

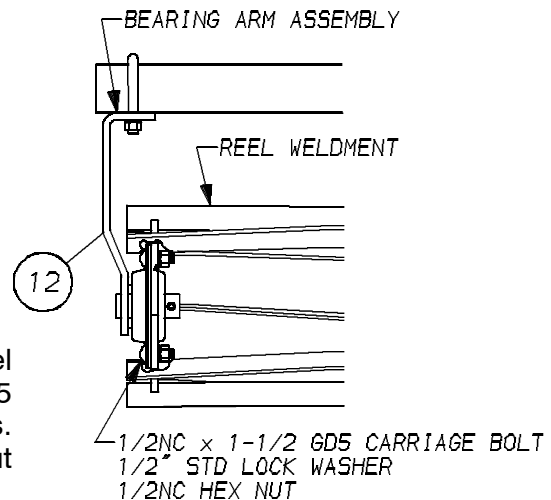

REV. 10/02
M6200-84

MODEL NUMBER



Know the model number of the Landsman being assembled. Use this model number whenever referring to the assembly, parts listing pages or placement pages. The number is stamped on the Name Plate which is located on the front frame member.

Refer to the Parts Illustration to identify the parts during the assembly procedure. Read each step through before beginning the actual assembly process.

I. CENTER FRAME ASSEMBLY

1. Models TL6200 9, 12, 15 -- refer to illustration on page P2. Place the RIGHT and LEFT FRAMES on suitable stands, 40" high. The TONGUE MOUNTS should point down.
 - A. Bolt the two halves together with 3/4NC x 2" GD5 Bolts, Lock Washers, and Hex Nuts. Do not tighten bolts until completing step D below.
 - B. Position the FRONT CONNECTOR WELDMENT 4 at the front with the hinge pivots down. Bolt loosely with 5/8NC x 5" Bolts, Lock Washers and Hex Nuts.
 - C. Install (2) FRAME CONNECTOR WELDMENTS 3 using 3/4NC x 2" GD5 Bolts, Lock Washers and Hex Nuts.
 - D. Clamp SHANK BOX 5 to frames with BOX CLAMP 8 and 5/8NC x 6-1/2" GD5 Bolts, Flat Washer, Lock Washer and Hex Nut. Tighten all bolts.
 - E. Refer to rocker illustration on page P6. Insert ROCKER CASTING 24 in each end of the rocker. Position TWO BEARING PLATES 28 on top of frame. Place rocker on top of frame and between outer frame bars. The wheel arms should point towards the front and the leveler lugs should be on top.
 - F. The ROCKER CASTING 24 may need to be rotated to align the holes with the holes in the frame box. Bolt the castings in place with 3/4NC x 5-1/2" GD5 Bolts, Flat Washers, Lock Washers and Hex Nuts. If assembling a TL 6200 -15, also fasten 12 and 13, page P2 to castings.
 - G. Place the ROCKER CLAMPS 14 over the rocker and bolt through bearing plates and frame with 3/4NC x 6" GD5 Bolts, Flat Washers, Lock Washers and Hex Nuts.
 - H. Bolt CYLINDER LUG 27 to the outside of each wheel arm with 5/8NC X 4-1/2" GD5 Bolts, Lock Washers and Hex Nuts.
 - I. Fasten TWO CYLINDER BRACKETS 29 to the frame with 1NC x 3" GD5 Bolts, Lock Washers and Hex Nuts.

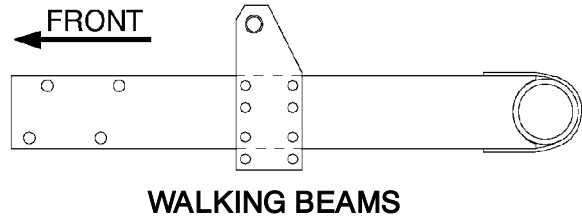

NOTE: Cylinder Brackets can be installed with strap on top or bottom side (see illustration at right.)

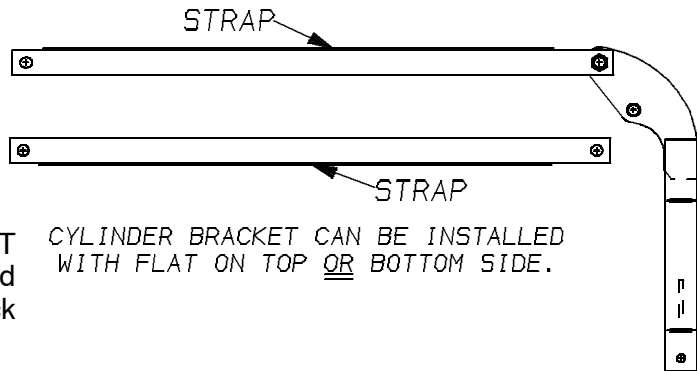

- J. Connect CYLINDER BRACKET LINKS 33 to cylinder bracket and frame with 1NC x 3" Bolts, Lock Washers and Hex Nuts.
- K. Pin a 4" x 10" HYDRAULIC CYLINDER to the cylinder bracket and rocker lug. The cylinder rod should point down. Loosen BOTH port plugs to allow cylinders to extend.
- L. Pin a MAINTENANCE LOCK 34 over each extended cylinder rod.
- M. Tighten all bolts; rocker must be free to pivot.
- N. Bolt LUGS 16 & 19 to the rocker with 5/8NC x 2" Bolts Lock Washers and Hex Nuts. Note the different positions for walking beams or single tires.
- O. Place LEVELER LINKAGE 1 on top of center frame. Place end of linkage between lugs on rocker and fasten with BOLTS 6 and 8 into the top holes.
- P. Follow Step II.

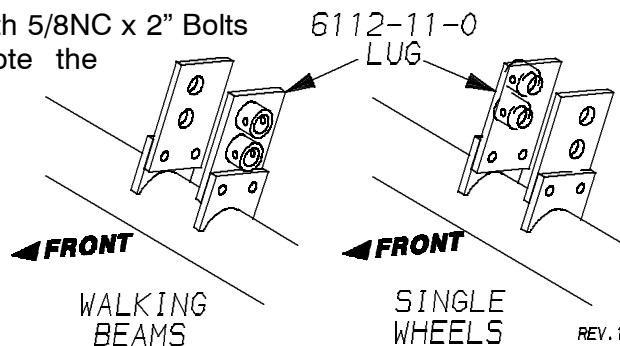

REV. 11/04
M6200-85

REV. 10/02
M6200-86

2. MODELS TL 6200 - 18, 21, 24 -- refer to illustration on page P3. Place the center frame on suitable stands, 40" high. The tongue mounts point down.
 - A. Bolt (2) CYLINDER BRACKETS 23 , page P8 to frame with 1NC x 3" GD5 Bolts, Lock Washers and Hex Nuts.
 - B. Pin (2) 4" x 10" cylinders, 21-1007, to the cylinder bracket and rocker lugs. The cylinder rod end should point up. Loosen both port plugs to allow cylinders to extend.
 - C. Pin a MAINTENANCE LOCK 27 over each extended cylinder rod.
 - D. Tighten all bolts; rocker must be free to pivot.
 - E. Place the LEVELER LINKAGE 1 on top of center frame. Place end of linkage between lugs on rocker and fasten with BOLTS 6 and 8 into top holes.
 - F. Follow Step II.

3. MODELS TL 6200 - 27, 31, 36, 42 & 45 -- refer to the illustration on page P4. Place the REAR FRAME 3 on suitable stands 40" high. The lugs should be on the top side and the wing hinges to the rear.
 - A. Place the RIGHT 1 and LEFT 2 MAIN FRAMES on top of the rear frame and on suitable stands. The tongue mounts should point down.
 - B. Bolt the main frames to the rear frame with 1NC x 14" Bolts, and 1NC x 16" Bolts, Flat Washers, Lock Washers and Hex Nuts. DO NOT TIGHTEN BOLTS UNTIL COMPLETING STEP D.
 - C. Position the FRAME CONNECTOR WELDMENT 5 between the main frames with the smaller box on top. Bolt the frame connector to each main frame with 3/4NC x 6" & 3/4NC x 2" GD5 Bolts, Lock Washers and Hex Nuts.
 - D. Position the FRONT CONNECTOR WELDMENT 4 at the front with the hinge pivots down. Fasten it to the main frames with 3/4NC x 6-1/2" Bolts, Lock Washers, and Hex Nuts. Position (2) FRAME CONNECTOR 6 , fasten with 3/4NC x 2" Bolts Lock Washers and Hex Nuts. TIGHTEN ALL BOLTS.
 - E. Bolt (2) CYLINDER BRACKETS 19 , page P10 to rear frame with 3/4NC x 2" GD5 Bolts, Lock Washers, and Hex Nuts.
 - F. MODELS TL 6200 - 36, 42 & 45 ONLY: Install (2) WING STOP WELDMENTS 22 as shown in illustration on page P4 using 3/4NC x 5" GD5 Cap Screws, Lock Washers and Hex Nuts. Be sure that the weldment is installed so that the stop plate is parallel to the main frame. (see illustration to the right).
 - G. Add CYLINDER BRACKET LINKS 23 to cylinder bracket and frame with 1NC x 3" Bolts, Lock Washers, and Hex Nuts.
 - H. Pin (2) 4" x 10" (4-1/4" x 10 on Models TL6200 36, 42 & 45) Cylinders, to cylinder bracket and rocker lugs. The cylinder rod ends should point up. Loosen both port plugs to allow cylinders to extend.
 - I. Pin a MAINTENANCE LOCK 26 over each extended cylinder rod.
 - J. Tighten all bolts; rocker must be free to pivot.
 - K. Place SPRING LEVELER LINKAGE 1 on top of center frame. Place end of linkage between lugs on rocker and fasten with PIN 9 in top hole.
 - L. Follow Step II.

NOTE: TOP OF WING STOP MUST BE PARALLEL TO TOP OF FRAME.

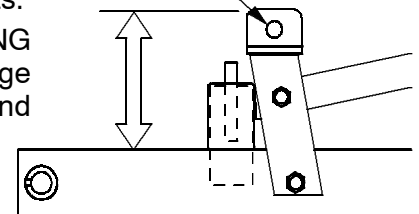

M6200-28



M6200-40

II. TONGUE ASSEMBLY

MODELS TL 6200 9, 12, 15, 18, 21 & 24: Refer to the illustration on page P12.

1. Connect TONGUE 13 to center frame using SQUARE HEADED PINS 14 and 3/8" DIA. x 1-3/4" Roll Pins. The box lug should be on the top side.
2. Pin TONGUE JACK 27 to tongue.
3. Insert LINK WELDMENT 9 through box lug and through LEVELER LINK. Place STRAP 8 over the pins and retain with 3/8" DIA. x 1-3/4" Roll Pins.
4. Place end of JACK ASSEMBLY 1 between straps on LEVELER LINK and fasten with PIN and Roll Pins.
5. Adjust jack assembly or adjust tongue jack to align with holes in tongue, and fasten in place with PIN and Roll Pins.
6. Bolt safety chain to tongue with 3/4NC x 3" Bolt, (2) Flat Washers and Lock Nut.
7. Attach HOSE CARRIER 12 (see page P49) to tongue and secure with a 3/16" DIA. x 1-3/4" Cotter Pin.
8. Proceed to Step III.

MODELS TL 6200 27, 31, 36, 42 & 45: Refer to the illustration on page P14.

1. Connect TONGUE 14 to center frame using SQUARE HEADED PINS 15 and 3/8" DIA. x 1-3/4" Roll Pins. The box lug should be on the top side.
2. Pin TONGUE JACK 30 to tongue.
3. Attach CONNECTOR LUGS 8 to box lug with PIN 17 and Roll Pins.
4. Pin TURNBUCKLE 1 between CONNECTOR LUGS 8 with PIN 17 and Roll Pins.
5. Insert casting on leveler link between CONNECTOR LUGS. Secure connector lugs with 1NC x 7-1/2" Bolt and Spacers.
6. Adjust jack assembly or turnbuckle to align turnbuckle clevis with holes in lugs on tongue; fasten in place with PIN 17 and Roll Pins.
7. Bolt safety chain to tongue with 3/4NC x 3" Bolt, (2) Flat Washers and Lock Nut.
8. Attach HOSE CARRIER 12 (see page P49) to tongue and secure with a 3/16" DIA. x 1-3/4" Cotter Pin.
9. Proceed to Step III.

IMPORTANT: Tractors with a higher than normal drawbar, may lift the front of the Landsman during field operation. This will limit disc gang penetration and cause the unit to be unlevel in the field. This is likely to occur with tractors having a drawbar height over 18". To correct the problem, raise the tongue to the upper hole position.

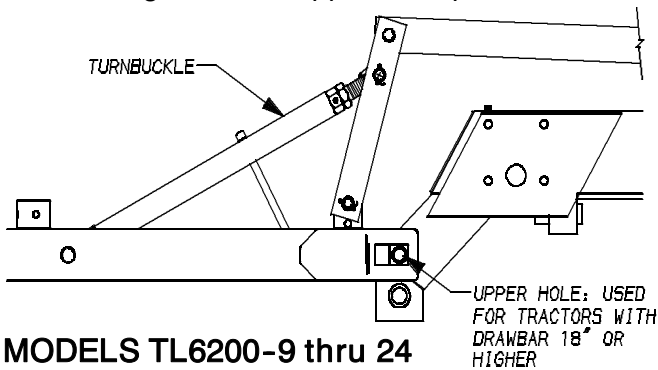

MODELS TL6200-9 thru 24

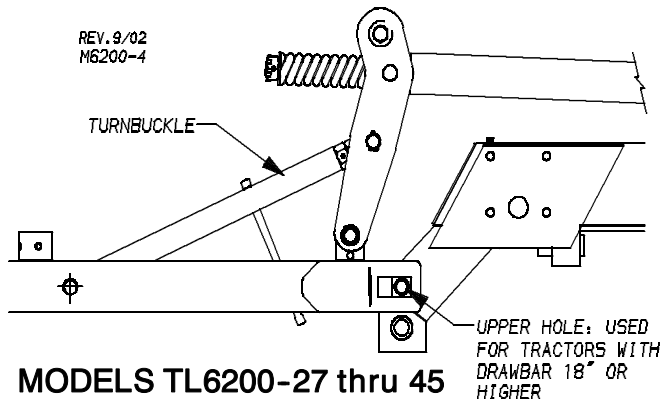

MODELS TL6200-27 thru 45

If the front of the Landsman is too high in transport, the leveling link can be moved to the lower hole to lessen tongue movement.

When making this adjustment on Models TL 6200 36, 42 and 45; also move the leveling link to the 2nd hole as shown in the illustration shown at right.

TL6200-27 thru 45
LEVELING LINK

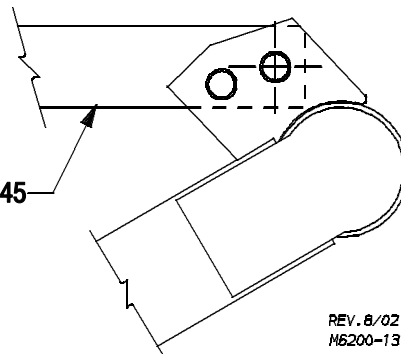

REV. 8./02
M6200-13

III. WALKING BEAM

1. Walking Beam Assembly. Refer to illustrations on pages P28 and P29.

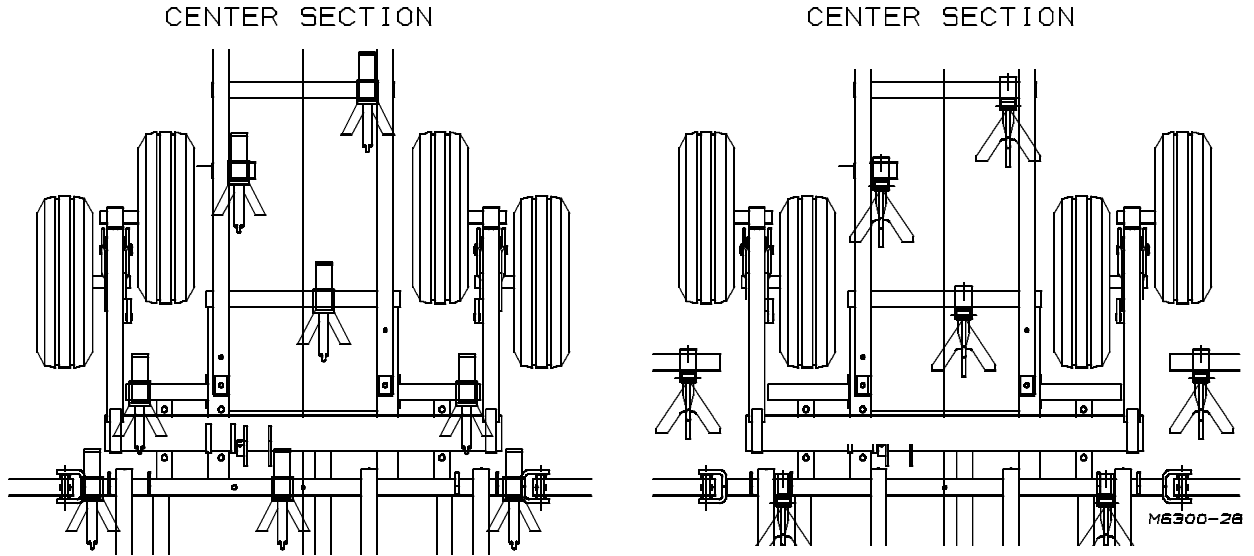

NOTE DIFFERENT TIRE POSITIONS FOR CENTER SECTION WALKING BEAMS

Refer to the placement pages at the back of this manual for correct walking beam position.

- A. Locate the walking beam assembly with grease zerk on top and the front hub positioned as shown above for the type of shanks and size of unit being assembled.
- B. Loosen the clamp bolt, if required, to slide the side plates onto the wheel arm.
- C. Fasten the walking beam with 3/4NC x 5" GD.5 Bolts, Lock Washers, and Hex Nuts. (TL6200 27 & 36 center rocker uses 3/4NC x 6-1/2" GD.5 Bolt, Lock Washers and Jam Nuts.)
- D. Tighten all bolts.
- E. Remove the WHEEL BOLTS from the hubs and attach the wheel and tire assemblies to the hubs.
- F. Check tire pressure. See Dealer Predelivery Check Sheet for correct tire size and pressure for center and wing locations. Torque wheel bolts (6 bolt hubs to 120 Ft. Lbs., 8 bolt hubs to 145 Ft. Lbs.)

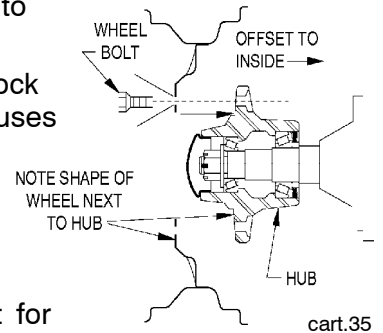

IV. SELF-SUPPORTING CENTER SECTION

Check all bolts for tightness; check pins for retention, and check installation of road locks. Then raise one side of the center frame and remove stands. Remove stands from the other side in a like manner. Center Section will now stand self-supported on its wheels and tongue jack.

V. WING FRAMES

1. Refer to the illustration on pages P19 thru P24 depending on your model.
- A. Position wing frames with disc gang hinges in front pointed down.

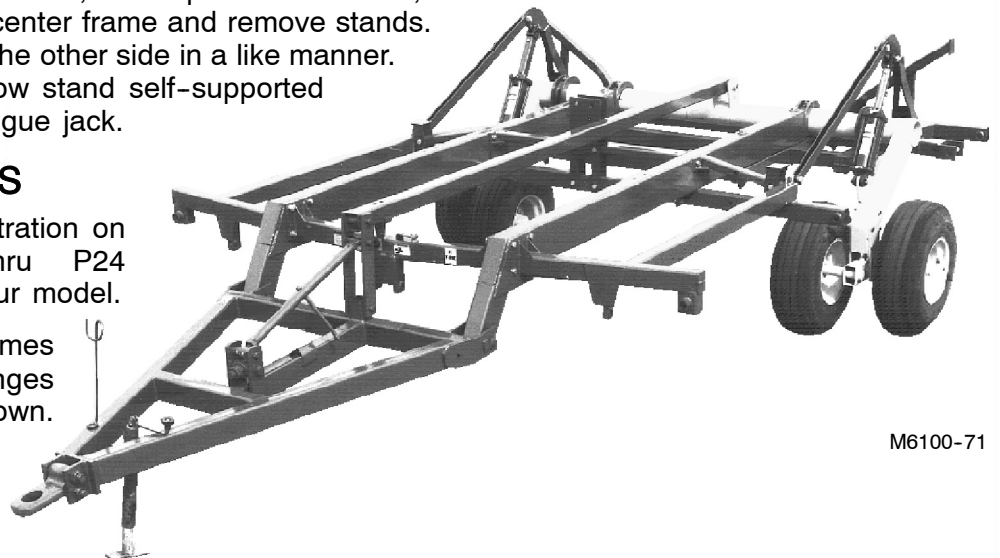

- B. Place HINGE BOLT 10 through the back three hinges. Slide wing frame rearward and check thrust contact at each hinge. Insert a 1-1/4" Flat Washer on the thrust side, if clearance allows it. Insert HINGE PIN 8 through front hinge. Install 3/8" DIA. x 1-3/4" Roll Pins in the hinge pin and 1-1/4NC Lock Nuts on the hinge bolts. Tighten hinge bolts until snug.
- C. Place support stands under outer wing frame members. Stands will need to support about 600 Lbs., until hydraulic cylinders are plumbed and actuated.
- D. Bolt (2) WINGS STOPS 2 at the rear of the center frame or the wing frame as shown in the placement pages with 3/4NC x 5-1/2" GD.5 bolts, Lock Washers, and Hex Nuts; and 3/4" DIA. U-Bolt, Lock Washers, and Hex Nuts.
- E. Models TL6200 24, 27 & 31 ONLY: Position front WING STOP 20 or 21 as shown in illustration to the right. Placement drawings will show correct location. Fasten with (2) 5/8NC x 9-1/2" GD.5 Bolts. (Model TL6200 24 uses (2) 5/8NC x 7-1/2" GD.5 Bolts), Lock Washers and Hex Nuts. Do not tighten until unit is folded and stops are positioned against wings.
Model TL6200 36, 42 & 45 only - Assemble outer wing frames in a similar manner. A shorter hinge bolt is used in the second hinge.
- F. TL 6200 42 & 45 ONLY: The two halves of each inner wing should be assembled before connecting to the main frame.

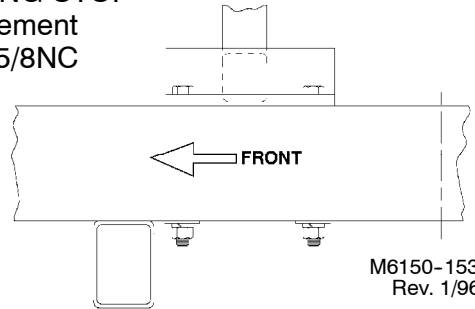

VI. WING ROCKER ASSEMBLY ALL MODELS

Models TL 6200 18 thru 31 (refer to page P20):

1. Place CYLINDER LUG 15 on the outside of each wheel arm with 5/8NC x 4-1/2" GD.5 Bolts, Lock Washers & Hex Nuts.

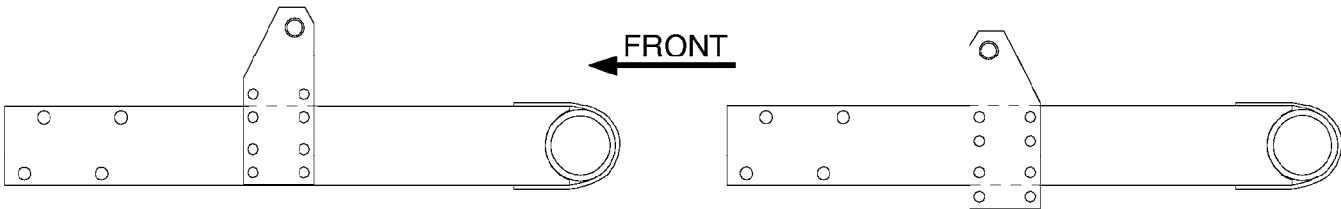

SINGLE WING TIRE Models TL 6200 18 & 21 ONLY

- A. Fasten CYLINDER BRACKET 6 to the frame with 1NC x 3" Bolts, Lock Washers & Nuts.
- B. Connect the CYLINDER BRACKET LINKS 9 to cylinder bracket and eyebolt with 1NC x 3" Bolts, Lock Washers, and Hex Nuts.
- C. Pin a 3-3/4" x 10" hydraulic cylinder to the cylinder bracket and the wheel arm. The cylinder rod should point up. Loosen both port plugs to allow cylinder to extend.
- D. Install (2) 1/8" DRIVE THREAD ZERKS into each rocker pipe.
- E. Tighten all bolts; rocker must pivot freely.
- F. Repeat Step III to install walking beam or single tire.



Model TL 6200 36, 42 & 45: Inner & Outer Wings refer to illustration on page P22.

- A. Fasten CYLINDER BRACKET 11 to lug with 1NC x 3" Bolt, Lock Washer and Hex Nut.
- B. Connect a CYLINDER BRACKET LINK 15 to the cylinder bracket and eyebolt with 1NC x 3" Bolts, Lock Washers and Hex Nuts.
- C. Pin a 4" x 10" hydraulic cylinder to the Inner Wing cylinder bracket and the wheel arm. Pin a 3-3/4" x 10" hydraulic cylinder to the Outer Wing cylinder bracket and wheel arm. The rod clevis should point up. Loosen both port plugs to allow the cylinder to extend.
- D. Tighten all bolts; rocker must pivot freely.
- E. Repeat Step III to install walking beams.

VII. WING FOLD ASSEMBLY

1. Models TL 6200 18 & 21 - refer to illustration on page P42.

Models TL 6200 24, 27 & 31 - refer to illustration on page P43.

- A. Bolt (2) WING FOLD PLATES 3 to each side of the center frame with 3/4NC x 5" GD5 Bolts, Lock Washers and Hex Nuts. Do not tighten until cylinder clevis is in place.
- B. Fasten a RIGHT and LEFT CYLINDER LUG 7 and 10 to the wing with 3/4NC x 5" GD5 Bolts, Lock Washers and Hex Nuts.
- C. Models TL 6200 18 & 21 - A 3/4NC x 6" GD5 Bolt and Flat Washer is inserted vertically with a SQUARE WASHER 12, Lock Washer and Hex Nuts on the bottom.
- D. Model TL 6200 27 & 31 - Clamp cylinder lugs to frame bar with 5/8" DIA. U-Bolt, Lock Washers and Hex Nuts.
- E. Pin base end of CYLINDER 4 between right and left cylinder lugs. The cylinder ports should be on the back side on Models TL 6200 18 & 21, and on the top side for Models TL 6200 24 thru 31. Retain cylinder with PIN 11 and 1/4" DIA. x 2-1/2" Roll Pins.

Models TL 6200 36, 42, 45: - - refer to illustration on page P44 or P46.

- A. Attach (2) FOLD PLATES 17 to center of unit with 3/4NC x 5"GD5 Bolts, Lock Washers, and Hex Nuts.
- B. Connect 5" x 32" HYDRAULIC CYLINDERS 20 with cylinder ports on the rear side of to fold plates with PIN 12 and 1/4"DIA. x 2" Roll Pins.
- C. Position WING LIFT BRACKET 6 on inner wings with U-Bolt 15, Lock Washers and Hex Nuts. Do not tighten.

TL 6200 36 ONLY: Go to illustration on page P45

- D. **Loosely** attach FOLD STRAPS 5 and 16 to WING LIFT BRACKET 6 with 3/4NC x 6" GD5 Bolt, Lock Washer and Hex Nut.

Insert the base end of 4" x 30" CYLINDER 13 between wing lift bracket side plates and over the cylinder lug welded on the outer wing frame and use PIN 15 with ROLL PINS 16 to secure it into place.

- E. Attach the ends of the FOLD STRAPS to the frame using (2) 3/4NC x 4-1/2" GD5 Bolts, Flat Washers, Lock Washers and Hex Nuts.

TL 6200 42 & 45 ONLY: Go to illustration on page P47

- F. Attach PLATE 16 (page P46) with 3/4NC x 6-1/2" Bolts, Lock Washers and Nuts. Pin base end of 4-1/2" x 32" CYLINDER 13 with cylinder pin 16.

IMPORTANT: FOLD STRAPS MUST BE IN TENSION DURING THE FOLD CYCLE. USE FLAT WASHERS AS NEEDED TO ELIMINATE SLACK BETWEEN FRAME MEMBER AND WING LIFT BRACKET. SEE ILLUSTRATION BELOW.

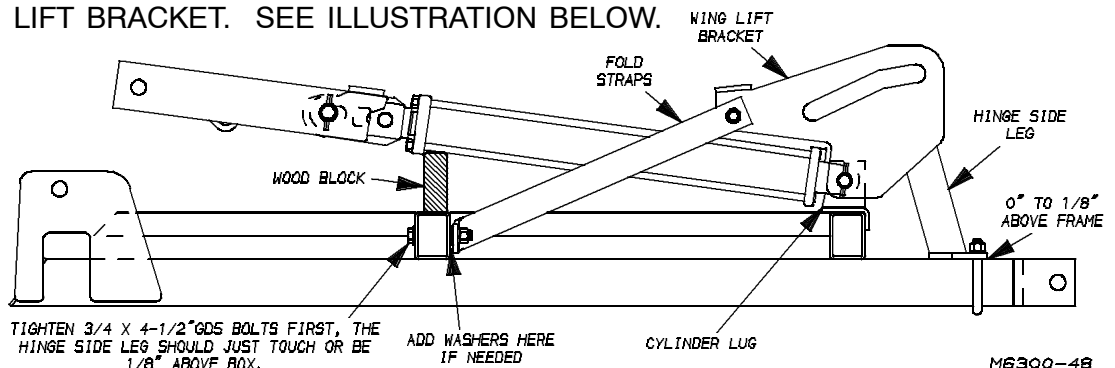

F. TIGHTEN ALL BOLTS.

IMPORTANT: DO NOT PIN ROD ENDS OF WING LIFT CYLINDER LUGS UNTIL ALL PLUMBING IS COMPLETE AND ENTIRE HYDRAULIC SYSTEM IS FULL OF OIL AND PURGED OF AIR.



VIII. GANG BEAMS -
SCRAPER BAR



Danger:

Due to their sharpness and weight, serious injury can be inflicted by blades and gangs if not handled safely. Watch for unsafe conditions. Keep your co-workers safety in mind. Should personal injury occur, have medical treatment administered immediately.

1. Position a Center Disc Gang Assembly under the center section, so that the long flat side of the End Plate is down and the scraper is to the rear.

2. Raise gang beam until Pivot Tubes line up and bolt with (2) 1NC x 4-1/2" Cap Screws. The lug on the gang beam will be on the outside of the lug on the frame. Use Heat Treated Flat Washers on both sides of hinge and secure with Slotted Hex Nut. Tighten slotted nut snug, but leave gang beams free to swing.

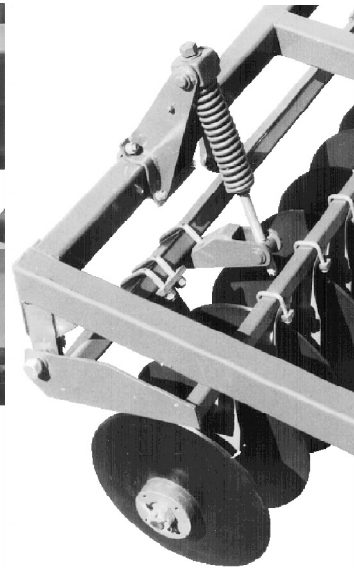
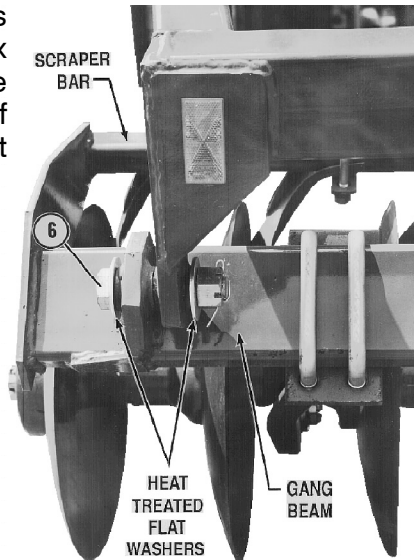

3. Refer to the Placement pages at the back of this manual for position of wing gang beams. Place them under the wings in the same manner as the center section.

4. Raise Wing Gang and pin inside pivot with 1NC x 4-1/2" Cap Screw, (2) Heat Treated Flat Washers and Slotted Hex Nut, and 3/16" DIA. x 1-3/4" Cotter Pin.

5. For Model TL 6200 31 ONLY: In the opposite end start a 1NC x 6" Cap Screw with a Heat Treated Flat Washer under the head. Insert just far enough to hold inner gang. Raise the outside disc gang to position and push 1NC x 6" Cap Screw through.

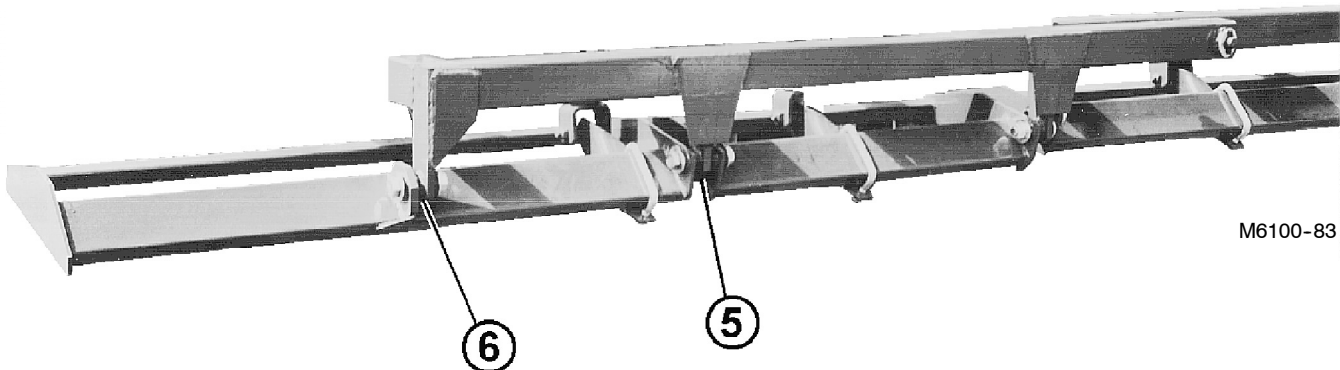

6. Secure outer end with 1NC x 4-1/2" Cap Screw, Heat Treated Flat Washer on each side, Slotted Hex Nut and a 3/16" DIA. x 1-3/4" Cotter Pin. Tighten all bolts so gangs will be free to swing. NOTE: Models TL 6200 24 & 27 will not use hinge point at 5. Model TL 6200 31 is shown at bottom of the previous page.
7. Refer to Shank Placement pages for positions of Disc Spring Support Assembly. Fasten assembly to the frame with U-Bolt (#61-228), Lock Washers, and Hex Nuts. Gangs of 9 Discs or larger will have (2) Spring Assemblies. See Optional Hydraulic Disc Gang Assembly on page A13.
8. Swing GANG BEAMS so that the scraper bar is to the rear and secure to spring supports with U-BOLT (#61-143), Lock Washers, and Hex Nuts.

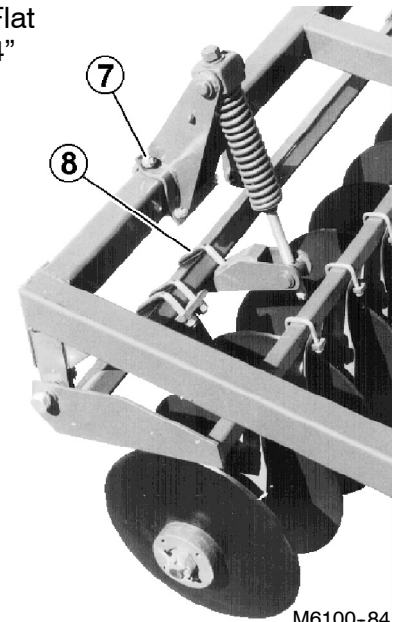

M6100-84

IX. UNASSEMBLED DISC GANGS OR REPAIR SEQUENCE

1. A few general steps to follow during disc gang assembly will insure correct gang attachment to the frame, and prevent future tear-downs due to improper assembly. Study the placement drawing for each gang and determine the following information.
 - A. The correct tie rod and spacer spools.
 - B. Note the direction of travel in relation to the disc blade position on the tie rod, and the location of the tie rod roll pin if at the hinge line.
 - C. Taper blades are added to assemblies as shown in the drawing.
2. The first tie rod shipping group selected for assembly will have washers, half spools and spacer spools on the tie rod with a 1-1/2NC SLOTTED HEX NUT 1 on each end. One nut is secured with a ROLL PIN 2 on one end of the tie rod and the nut on the opposite end is secured with a 3/8" DIA. x 3-1/2" COTTER PIN 3. Remove the cotter pin and disassemble the tie rod shipping group. The nut and cotter pin will be used at the end of the completed gang assembly. The shipping spacer tube can be discarded.

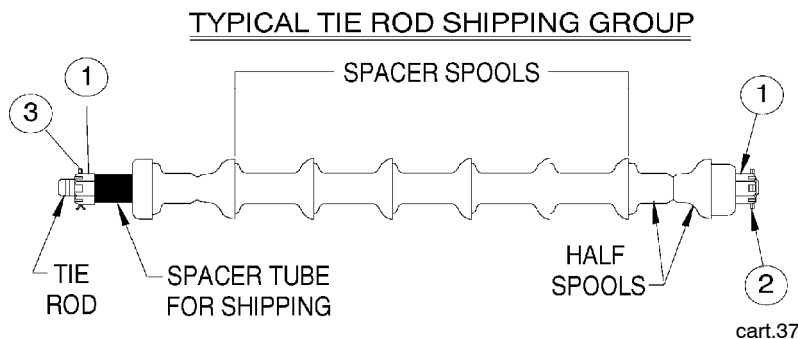

3. Using the preceding information and the placement drawings on A15 through A32 assemble the disc gangs. Note that all contact surfaces of the castings have been machined to fit the contour of the disc blades. ALWAYS place the bearing arm on the tie rod so that the BEARINGS 1 are located on the thrust side, or on the CONVEX SIDE 2 of the disc blades. Loosen (4) carriage bolts in bearing flange before gang assembly.

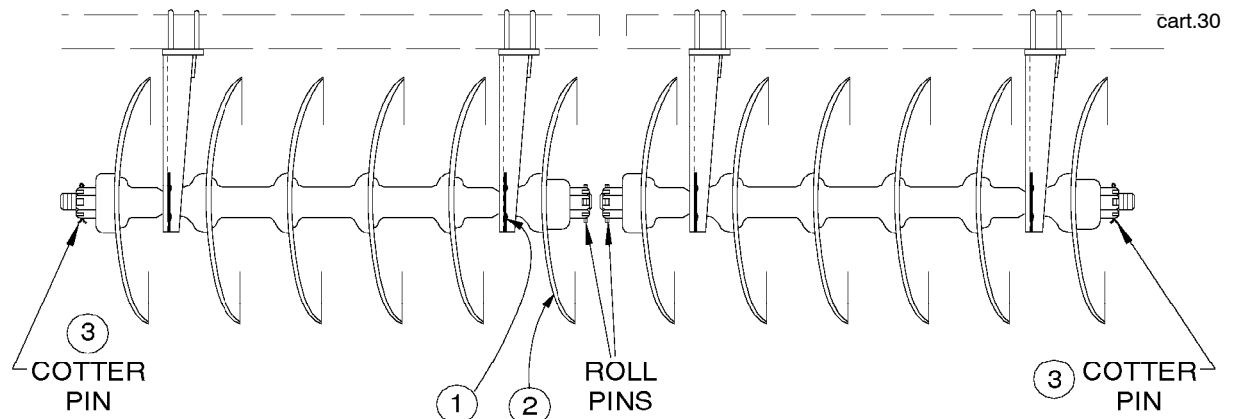

When the gang has been assembled, replace the slotted hex nut and torque to approximately 1,000 Ft. Lbs. Secure the nut with the 3/8" DIA. x 3-1/2" COTTER PIN 3. Clinch or spread the cotter pin to prevent loss.

4. Roll the completed gang assemblies under the frames at their specific locations.
5. Starting at the center gang, loop a length of chain under the center spacer spool and over the frame member and raise the gang until the bearing arm top plates touch the bottom of the frame. The loose flangette carriage bolts will allow the bearing arm to be adjusted square with the frame member.

Attach the bearing arm top plate to the bottom of the frame with (2) U-BOLTS 1, and (4) 3/4" STD. Lock Washers, and 3/4NC Hex Nuts. Adjust the gang to the dimension shown and tighten the U-Bolts. As the U-Bolts are drawn up tight, be sure the top plate raises flat against the frame and **not tilted to one side**, causing a lever action that preloads the bearings. See illustration below.

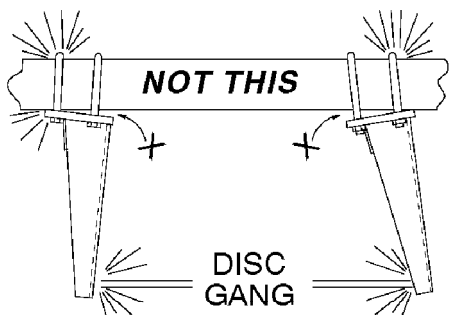

BE SURE THE BEARING ARM FITS FLAT AGAINST THE GANG BEFORE TIGHTENING THE U-BOLTS.

cart.28

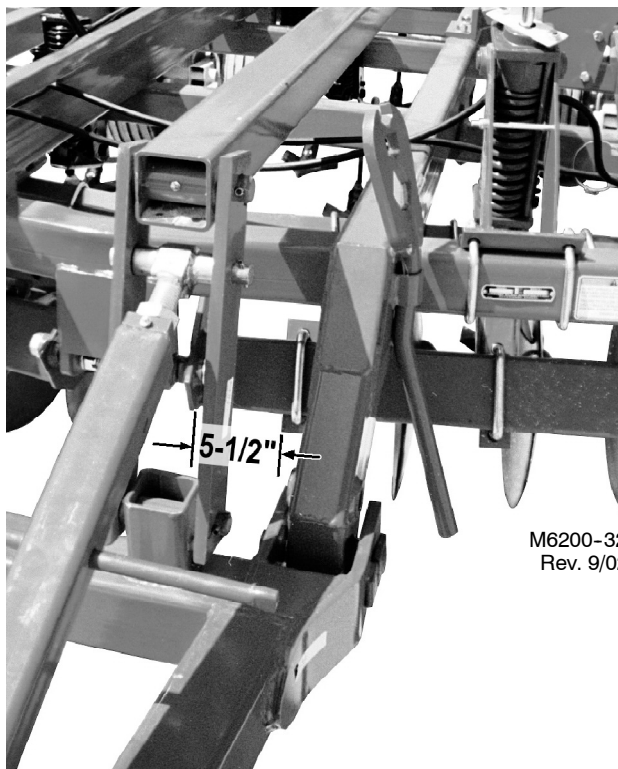

M6200-32
Rev. 9/02

6. Attach Wing Disc Gangs in the same manner. Slide gang until there is a 9-1/8" Space between the disc blades.

MODEL TL 6200 31 SHOWN

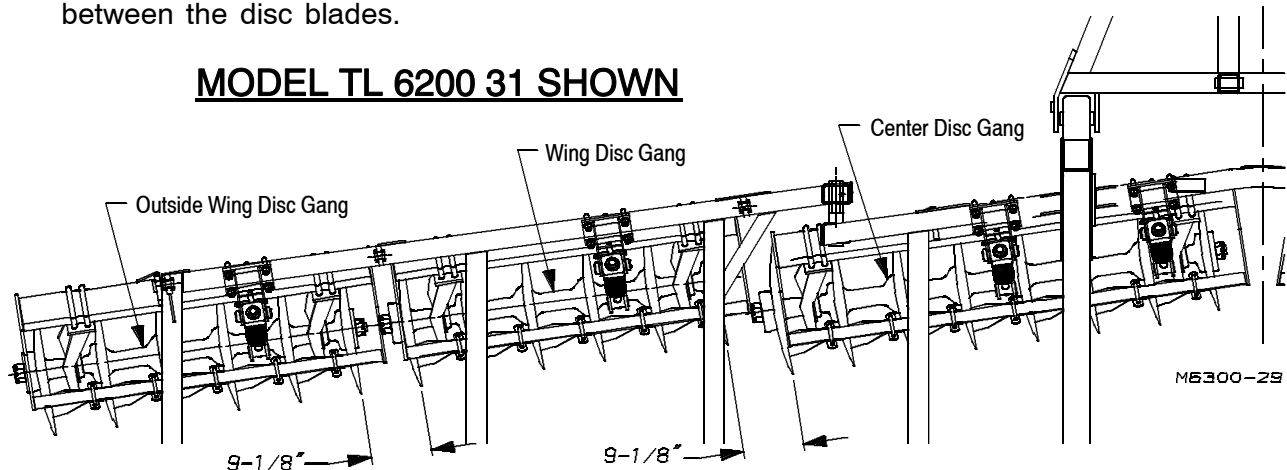

M6300-29

7. Tighten all U-Bolts. As the U-Bolts are drawn up tight, be sure that the top plate raises flat against the frame and not tilted to one side, causing a lever action that preloads the bearings.
8. Tighten the carriage bolts in the bearing flange.

X. DISC SCRAPERS

- Adjust each scraper blade within 1/8" of the disc blade.
IMPORTANT: DO NOT RESTRICT THE ROTATION OF THE GANG BY FORCING THE SCRAPER BLADE AGAINST THE DISC BLADES.

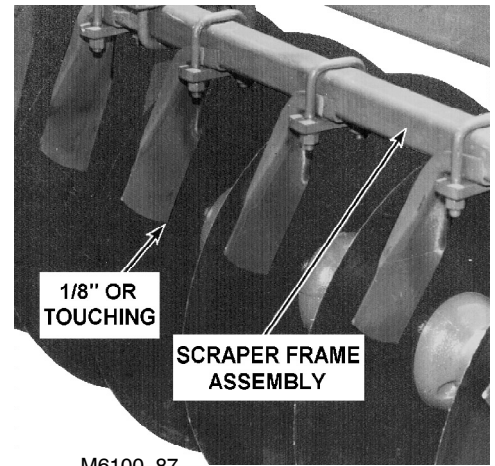

XI. SHANK EXTENSION ASSEMBLY

Refer to frame illustrations for extension part numbers and hardware. Refer to placement pages for extension positions for the model being assembled.

XII. 2-PIECE K-TINE SHANKS

- Refer to Placement Drawings at the back of this manual for shank locations and method of assembly.

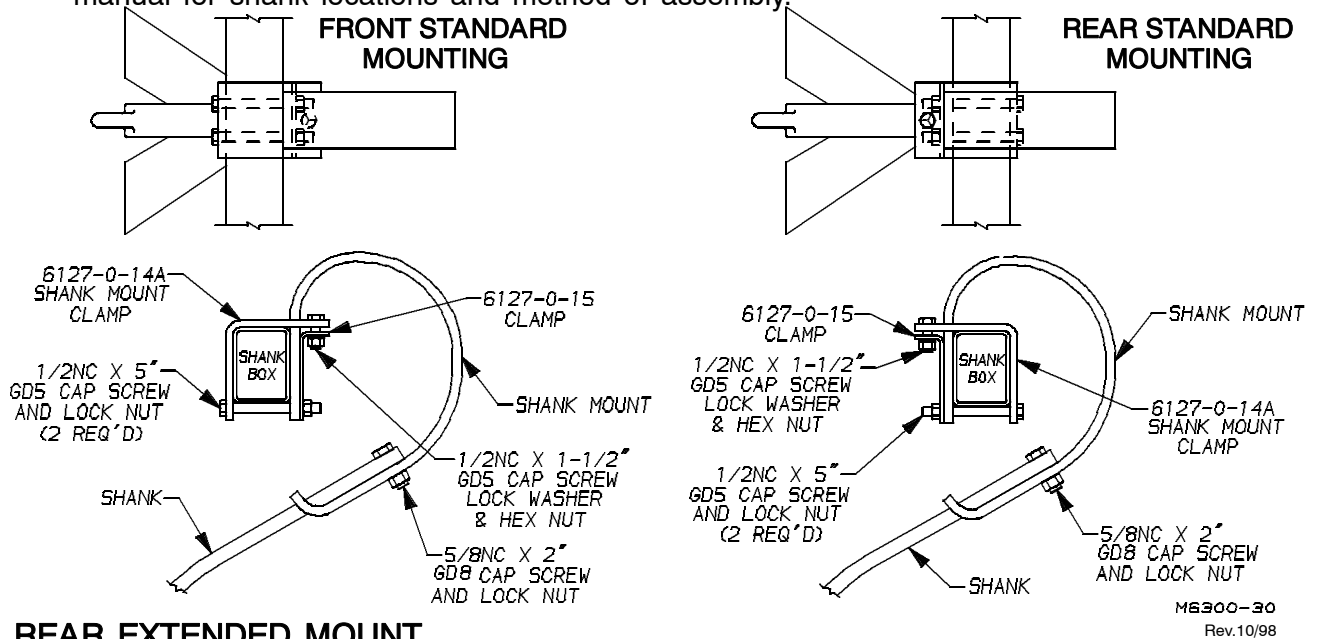

REAR EXTENDED MOUNT

Some models may require a shank to be mounted using the rear extended mount shown below. Refer to the placement drawings at the back of this manual for your model.

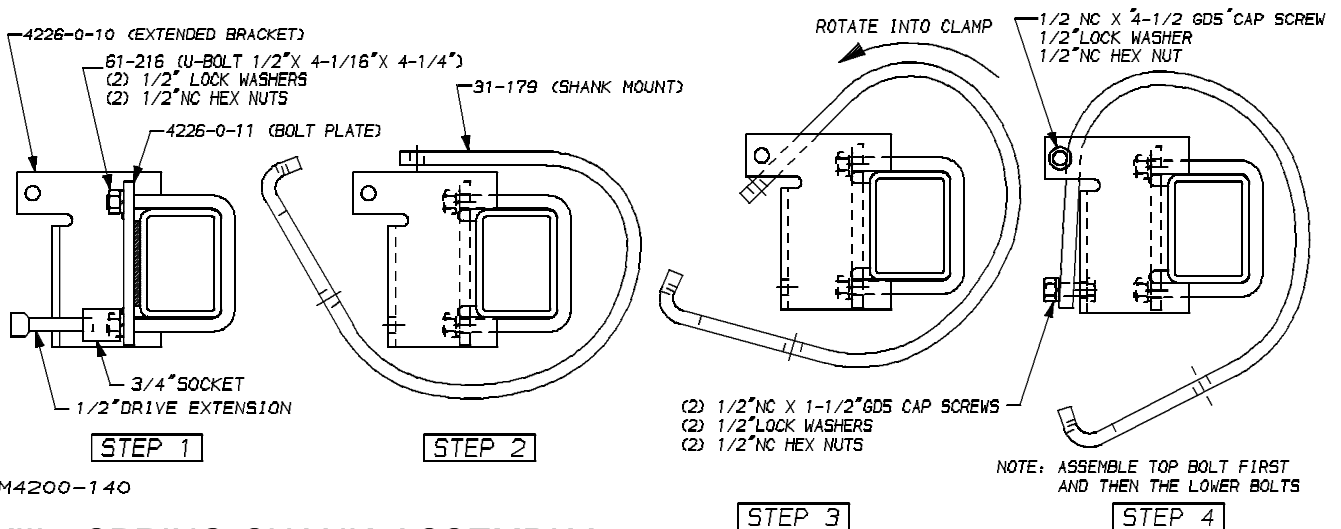

XIII. SPRING SHANK ASSEMBLY

Refer to the illustration at right and to the placement drawing at the back of this manual for shank locations.

- A. Loosen spring tension bolt until the spring plate is above the notch in the side plates.
- B. Rotate the spring assembly forward.
- C. Fasten the shank assembly to the frame using (1) 61-155 U-Bolt, (2) 5/8" STD. Lock Washers, and 5/8NC Hex Nuts.
- D. Rotate the spring assembly back to the vertical position and retighten the 5/8NC tension bolt. The top of the spring assembly^① should touch the bottom of the spring plate^②.

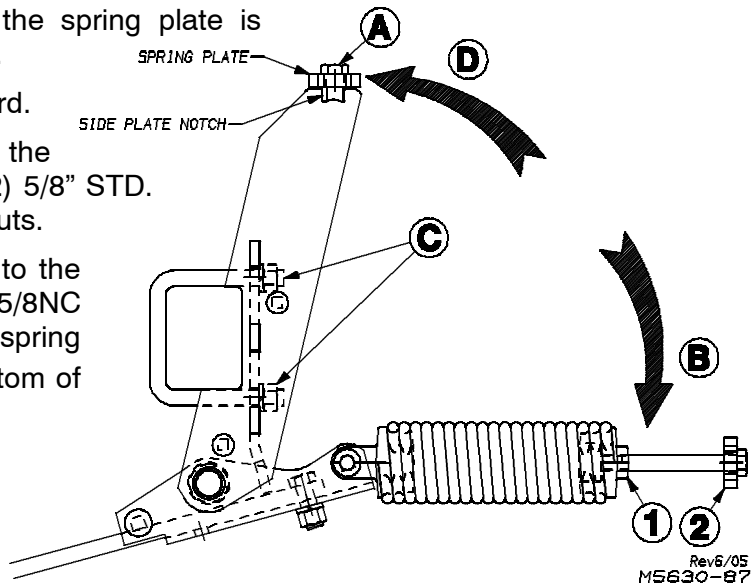

XIV. HYDRAULICS ASSEMBLY

1. Bolt GUIDE ASSEMBLY to the DEPTH VALVE ASSEMBLY and the bracket on the frame with (2) 3/8NC x 4-1/2" GD.5 Bolts. The VALVE PLUNGER must be towards the front of the unit.
2. Insert LINKAGE through the GUIDE ASSEMBLY.
3. Assemble ACTUATOR ARM with 3/8" DIA. U-Bolt to the main rocker. The actuator arm should be in-line with the valve bracket at the front of the frame. DO NOT tighten the U-Bolt.

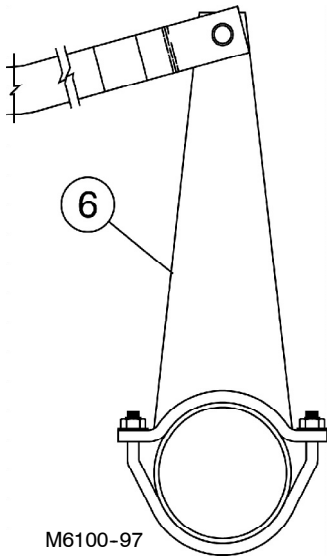

4. Connect LINKAGE to the actuator arm with a 1/2" DIA. x 1-1/2" Clevis Pin. The bend in the linkage should be down.

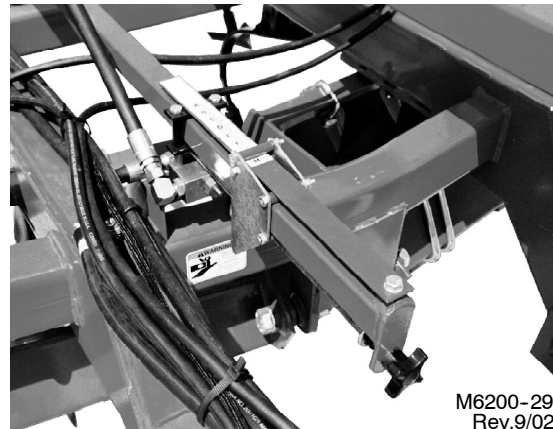

5. The ACTUATOR ARM is positioned after all the hydraulic plumbing has been installed and the system bled of air. Then raise the wheels completely off the ground and slide the linkage to the rear-most position, tighten U-Bolt securely. Raise the unit and test depth valve operation by positioning striker and lowering the unit.
6. Refer to the hydraulic plumbing pages in the Parts Section (pages P50 - P63) for the correct assembly of hoses, fittings, and hose clamps.

⚠ Caution: Use only hose that meets or exceeds 3,000 P.S.I. working pressure.

Note: No tape or liquid sealer is necessary on O-Ring Fittings or 37° Flare fittings.

IMPORTANT: A 90° RESTRICTOR SHOULD BE ASSEMBLED INTO ALL WING-LIFT CYLINDER ROD END PORTS. THE PROPER LOCATION OF THESE FITTINGS IS IMPORTANT TO PREVENT WINGS FROM FREE-FALLING IF A HYDRAULIC FAILURE OCCURS.

- A. Before filling system, place blocks of wood under each wing cylinder so that the cylinder rods will extend up and over the lugs to prevent damage to the cylinder while filling and purging the system of air.

7. CHARGING THE CYLINDERS :

- A. After all hose and fittings are assembled, check the blocks under the wing cylinders. Make sure that they are raised high enough to clear any attaching lugs.
- B. Attach hydraulic hoses to the tractor and pin to drawbar. Check the tractor hydraulic reservoir and make sure it is full of the manufacturer's recommended oil.
- C. If you are sure all connections are tight and leakproof, begin filling the system by extending and retracting the wing fold cylinders.
- D. The rocker shaft cylinders have rephasing grooves that will allow the oil to pass by the piston when the unit is fully raised. Hold the control lever open during each cycle, when the unit is raised and the cylinders are fully extended for 30 to 45 seconds. This will force oil through the rephasing grooves and allow the series cylinder to be charged with oil. Remove stands under wings and road locks, then cycle cylinders. Hold valve open until master and slave cylinders extend to their maximum.
- E. Continue the cycles until the cylinders respond with immediate solid actuation.



Warning: Escaping fluid under pressure can penetrate the skin causing serious injury. Avoid the hazard by relieving pressure before disconnecting hydraulic lines. Tighten all connections before applying pressure. Search for leaks with a piece of cardboard. Protect hands and body from high pressure fluids. If an accident occurs, see a doctor immediately. Any fluid injected into the skin must be surgically removed within a few hours or gangrene may result.

- F. After the wing cylinders are full, extend them to maximum length; remove the wood blocks. Pin the rod end of the wing cylinders to the wing lugs using the special pins, wear sleeves, 1-1/4" STD. Flat Washers, and 1/4" DIA. x 2" Roll Pins as shown in the drawing below.

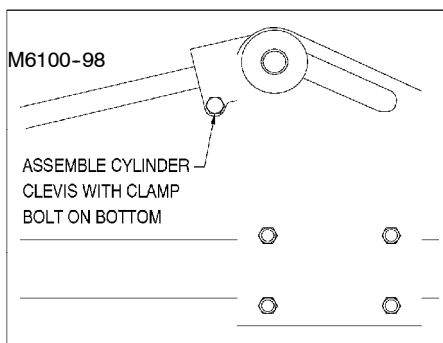

ALL WING MODELS

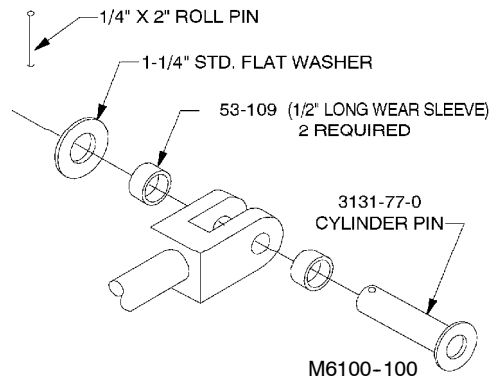

8. Model TL 6200 36: Pin the wing lift arm to the outer wings as shown.
9. Wings may now be folded to check function of cylinders unless the optional hydraulic disc gangs are used. Proceed to Step XV before folding the implement. Check hoses to ensure clearance around tires and wing stops. All hoses must be secure to avoid snagging hoses during operation.
10. Model TL 6200 36: Check tightness of set screw in clevis, to ensure clevis will not unscrew.

Adjust Sequence Valve if required. See page O23.

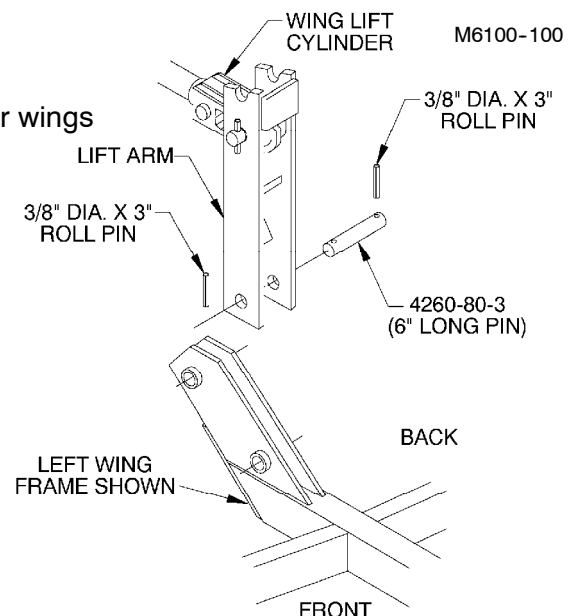

XV. DISC GANG HYDRAULICS ASSEMBLY

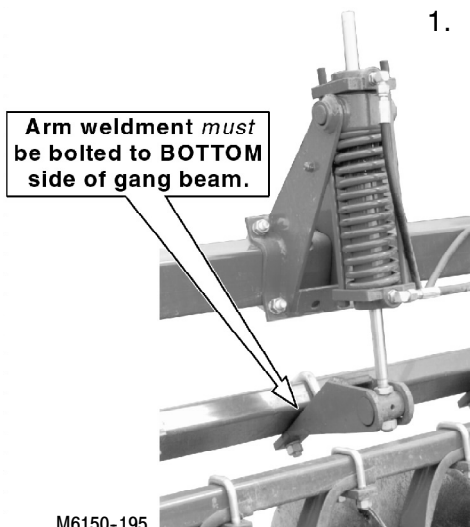

M6150-195

1. Refer to the hydraulic plumbing pages in the Parts Section for positions of the hydraulic cylinder support assembly. Fasten assembly to frame with U-Bolt (#61-228), Lock Washers, and Hex Nuts. Gangs of 8 discs or larger will have (2) assemblies.
2. Swing gang beam so that scraper is to the rear and secure arm weldment to bottom of gang beam with U-Bolt (#61-143), Lock Washers, and Hex Nuts. Loosening cylinder plugs will aid in extending cylinder.
3. Refer to pages P77-P83 in the Parts Section for correct assembly of hoses and fittings.

⚠ Caution: If replacing hydraulic hose, use only hose that meets or exceeds 3,000 P.S.I. working pressure.

- A. A restrictor elbow is required in the top port of the first cylinder plumbed to the tractor.
- B. Each cylinder is plumbed in series, as shown in the illustration to the right.
- C. When routing hoses avoid sharp edges and possible pinch points. Allow extra slack at the hinge joint.

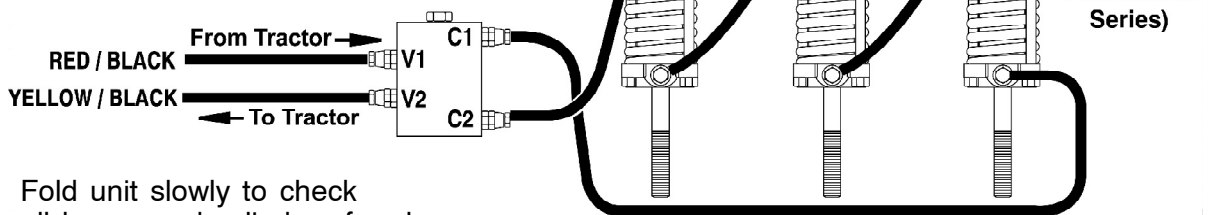

- D. Fold unit slowly to check all hoses and cylinders for clearance.

4. CHARGING THE CYLINDERS:

Before charging cylinders carefully read the safety information on page A13.

- A. Attach the hoses to the tractor and pin hitch clevis to drawbar. Check the tractor hydraulic reservoir and make sure it is full of the manufacturer's recommended oil.
 - B. If you are sure all connections are tight and leakproof, begin filling the system by raising the disc gangs. As each cylinder fills and raises the gang, it will bypass oil to allow the next cylinder to fill and raise.
 - C. When all gangs are raised, hold the lever 30 - 45 seconds to insure all cylinders are filled. Lower disc gangs and raise back up, they should move in unison. If not, repeat "raise-hold" cycle.
5. Install Depth Gauge Indicator on one cylinder that is easily viewed from the tractor. It should be positioned behind the cylinder rod when the cylinder rod raises out of the cylinder gland. Fasten the gauge with (2) 1/2NF Jam Nuts. **DO NOT OVER-TIGHTEN.**

DECALS

The DECALS are important to the safety of the operators, and to others, and must be attached to the unit at the proper locations. Some DECALS are applied to the proper location at the factory; however, these should be checked for location, and to be sure that they have not been damaged during shipping or set-up. Attach remaining decals as shown on parts pages P84 & P85.

LIGHT KIT

Always comply with state and local laws pertaining to lighting. Install the light kit as shown in illustration at the top of page A15 using parts shown on page P86.

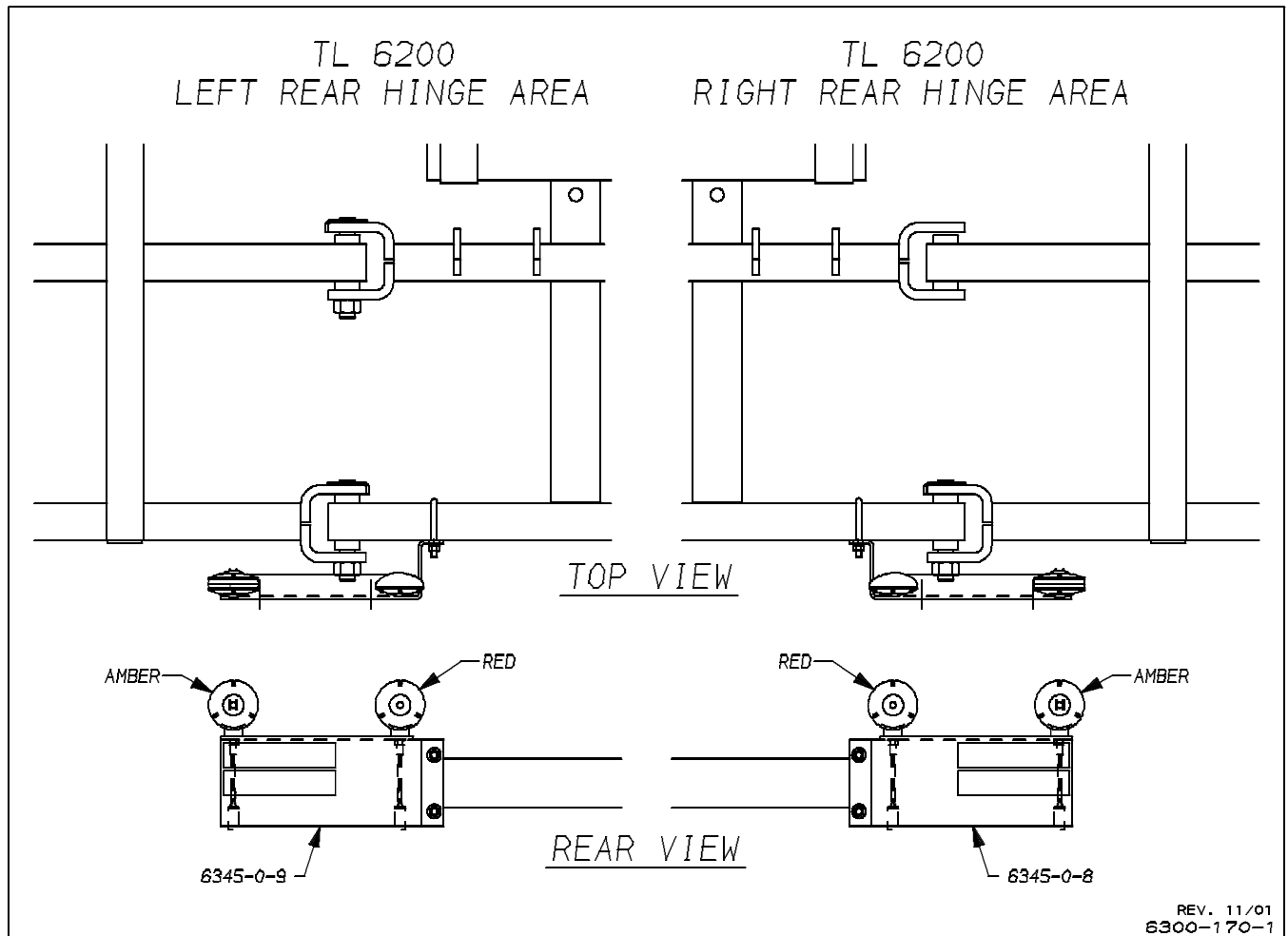

ASSEMBLE REAR HARROW AS DIRECTED IN THE HARROW ATTACHMENT BOOK

FINAL CHECK

1. Check the hydraulic system for leaks.
2. Lubricate all grease points
3. Check torque of all bolts.
4. Fully extend the depth control cylinders. Install road locks.
5. Lower tongue jack.
6. Check tire pressure and wheel bolt torque.
7. Check to be sure that the SMV Sign is clean and in place.
8. Perform final inspection. See Dealer Predelivery Check Sheet (follows Warranty page at the front of this manual.)

Caution: Explosive separation of a tire and rim parts can cause serious injury or death.

Always maintain correct tire pressure. Do not inflate tires above the recommended pressure. Inspect tires and wheels daily. Do not operate with low pressure, cuts, bubbles, damaged rims or missing lug bolts and nuts.

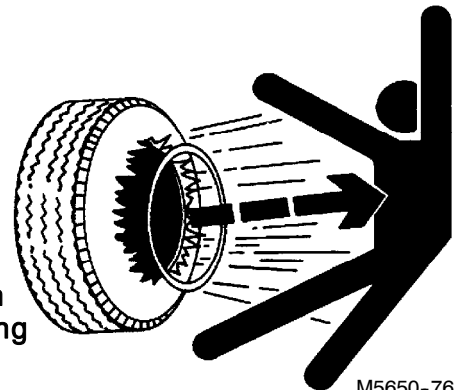

M5650-76

This page intentionally left blank.

PLACEMENT DRAWINGS

MODEL TL 6200-9
 7" SPACING UNIT
 SPRING SHANKS

TIE RODS

RIGHT CENTER 2146-82-1
 LEFT CENTER 2146-82-1

GANG BEAMS

RIGHT CENTER 6110-46-0
 LEFT CENTER 6110-46-0

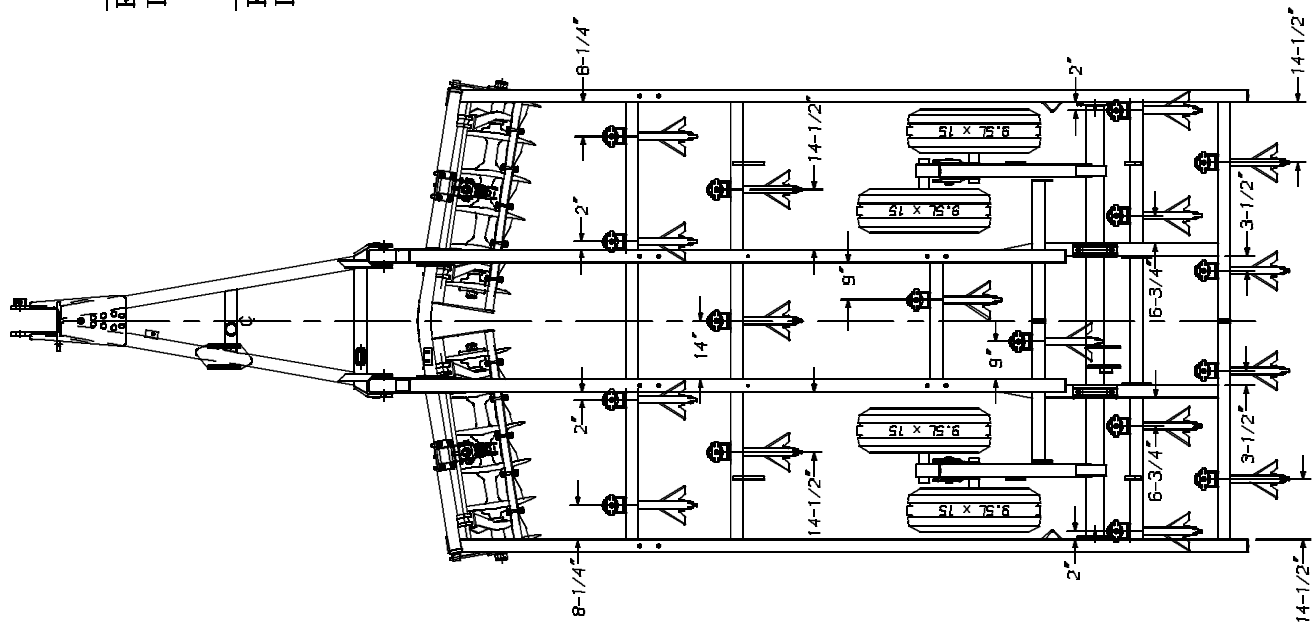

MODEL TL 6200-9
 7" SPACING UNIT
 2-PC K-TINE SHANKS

TIE RODS	
RIGHT CENTER	2146-82-1
LEFT CENTER	2146-82-1
GANG BEAMS	
RIGHT CENTER	6110-46-0
LEFT CENTER	6110-46-0

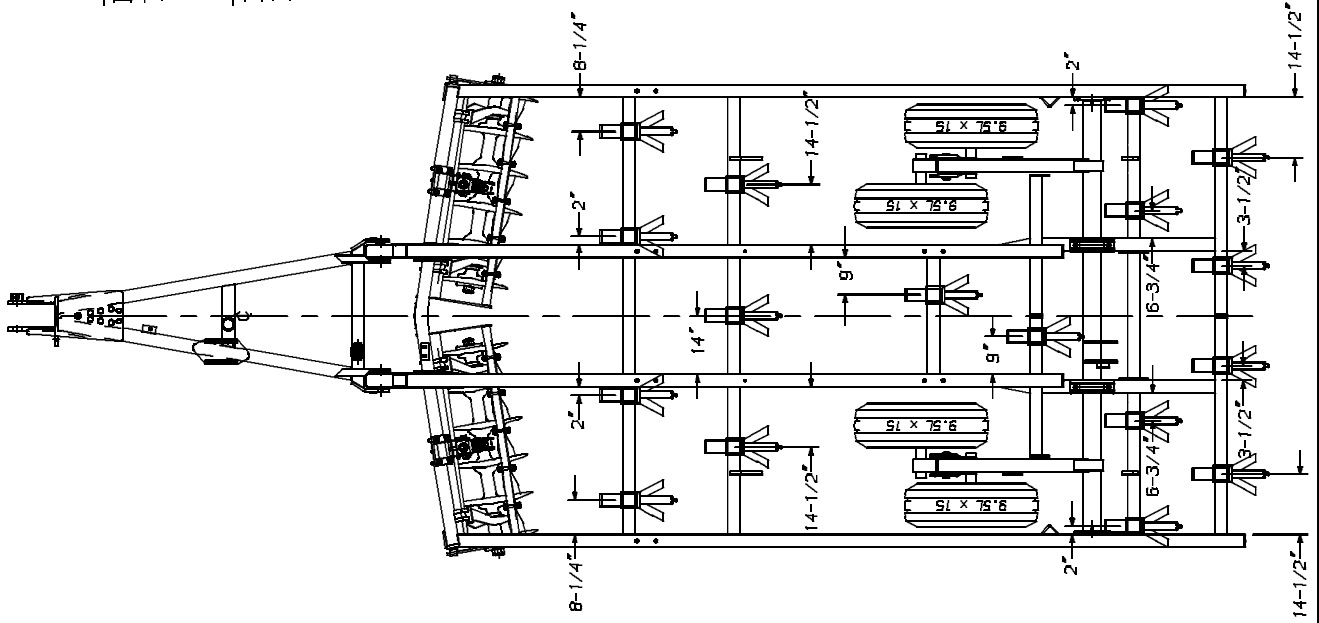

MODEL TL6200-9
 9" SPACING UNIT
 SPRING SHANKS

<u>TIE RODS</u>	
RIGHT CENTER	2146-82-1
LEFT CENTER	2146-82-1
<u>GANG BEAMS</u>	
RIGHT CENTER	6110-46-0
LEFT CENTER	6110-46-0

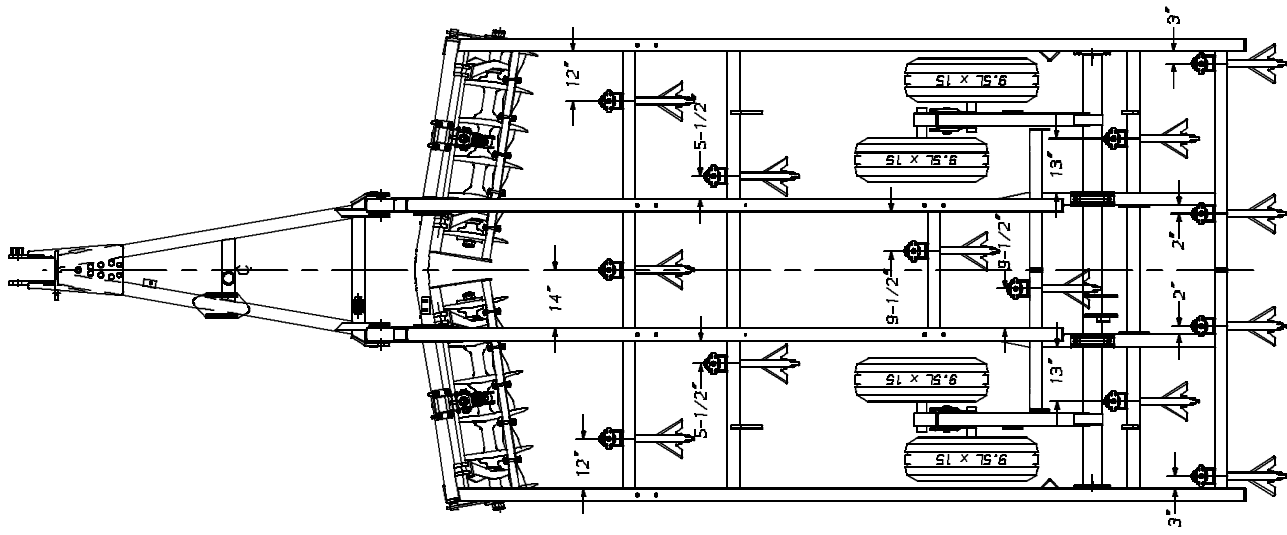

MODEL TL 6200-9
 9" SPACING UNIT
 2-PC K-TINE SHANKS

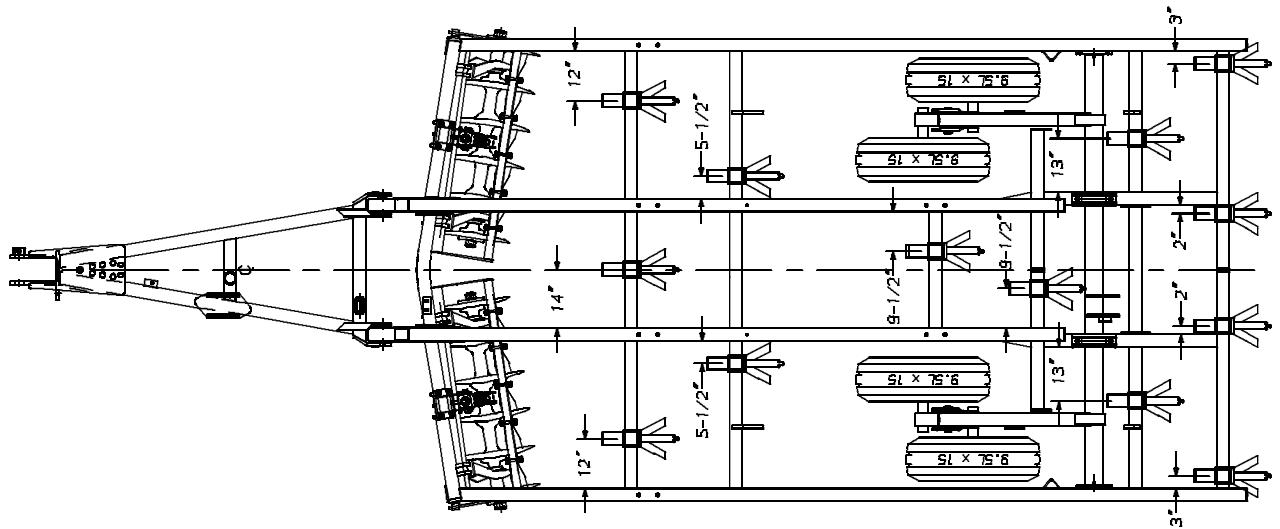

TIE RODS	
RIGHT CENTER	2146-82-1
LEFT CENTER	2146-82-1
GANG BEAMS	
RIGHT CENTER	6110-46-0
LEFT CENTER	6110-46-0

MODEL TL 6200-9
 9" SPACING UNIT
 XT 270 SHANKS

TIE RODS	
RIGHT CENTER	2146-82-1
LEFT CENTER	2146-82-1
GANG BEAMS	
RIGHT CENTER	6110-46-0
LEFT CENTER	6110-46-0

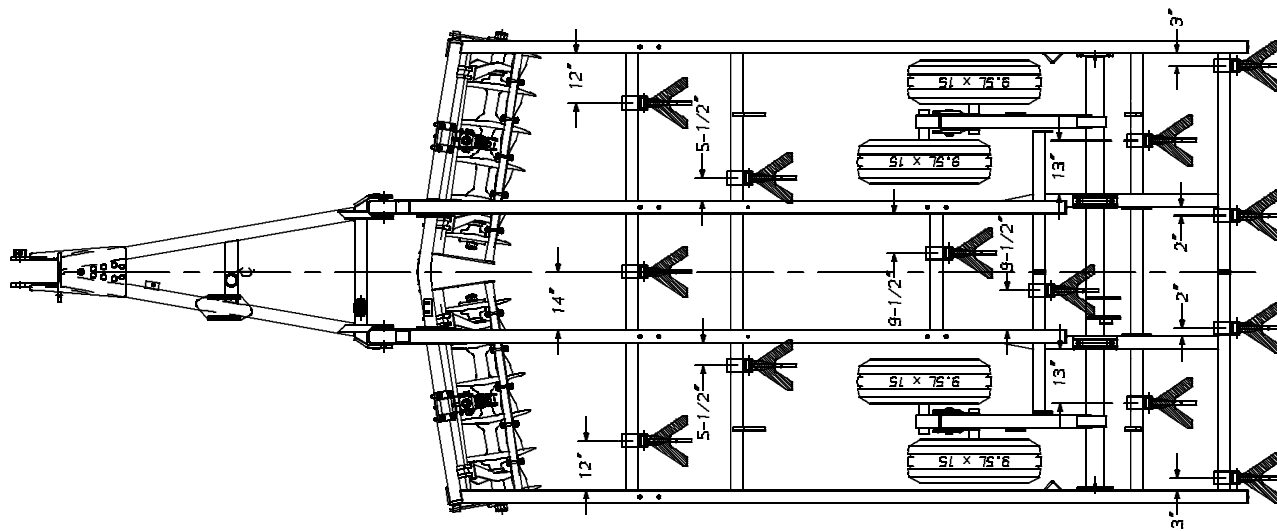

MODEL TL 6200-12
 7" SPACING UNIT
 SPRING SHANKS

TIE RODS	
RIGHT CENTER	2212-18-1
LEFT CENTER	2212-18-1
GANG BEAMS	
RIGHT CENTER	6112-46-0
LEFT CENTER	6112-47-0

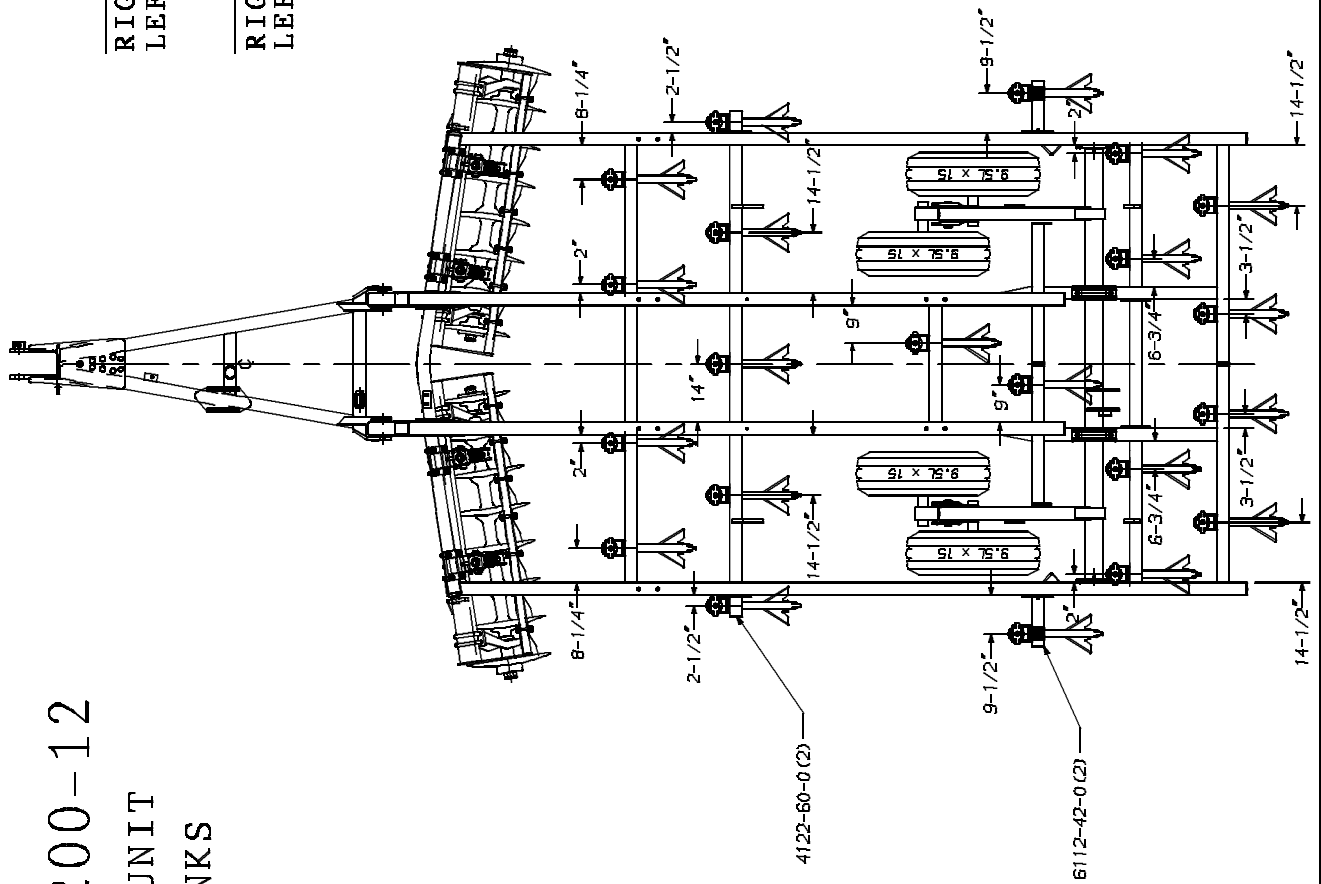

MODEL TL 6200-12
 7" SPACING UNIT
 2-PC K-TINE SHANKS

TIE RODS	
RIGHT CENTER	2212-18-1
LEFT CENTER	2212-18-1
GANG BEAMS	
RIGHT CENTER	6112-46-0
LEFT CENTER	6112-47-0

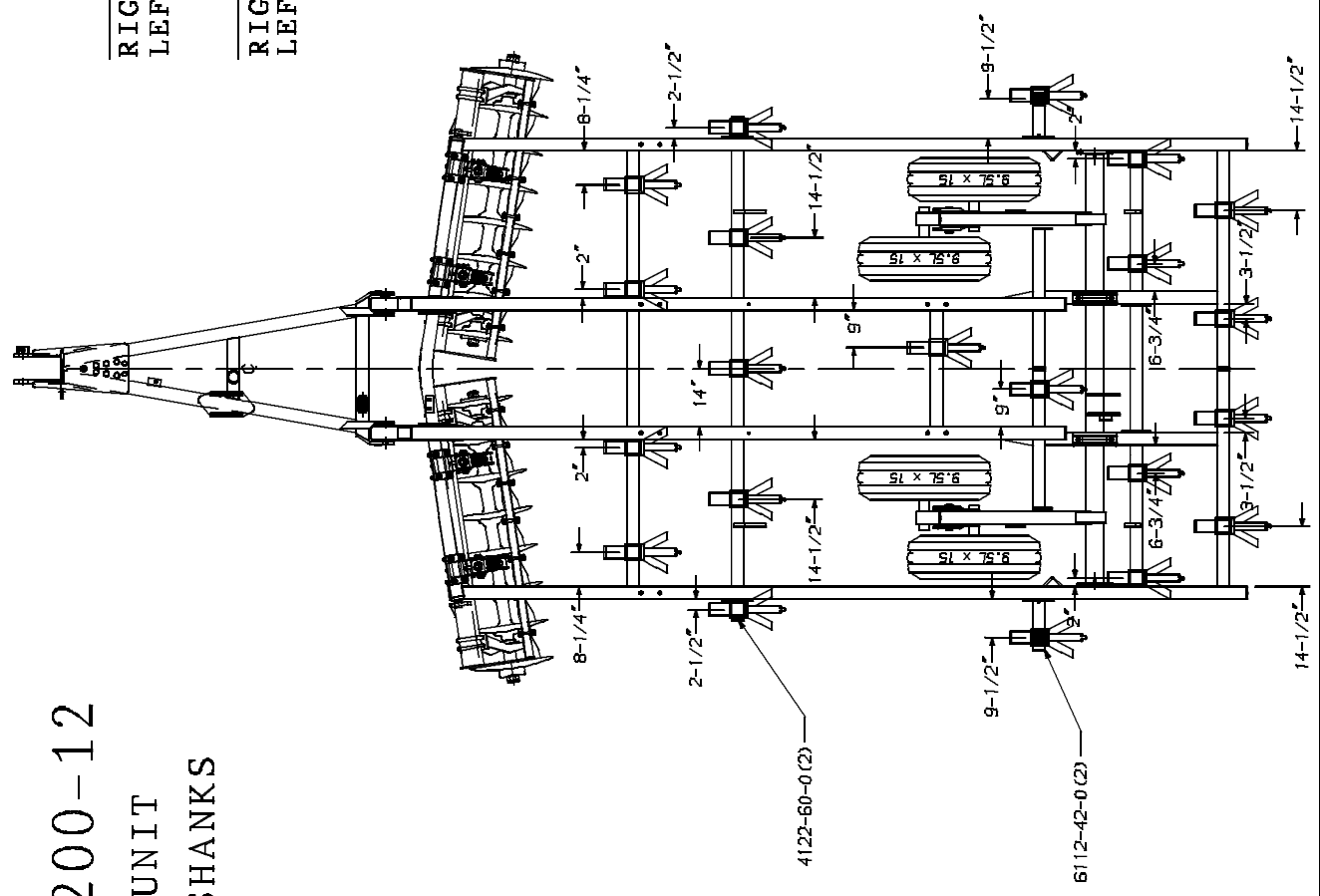

MODEL TL 6200-12
 9" SPACING UNIT
 SPRING SHANKS

TIE RODS	
RIGHT CENTER	2212-18-1
LEFT CENTER	2212-18-1
GANG BEAMS	
RIGHT CENTER	6112-46-0
LEFT CENTER	6112-47-0

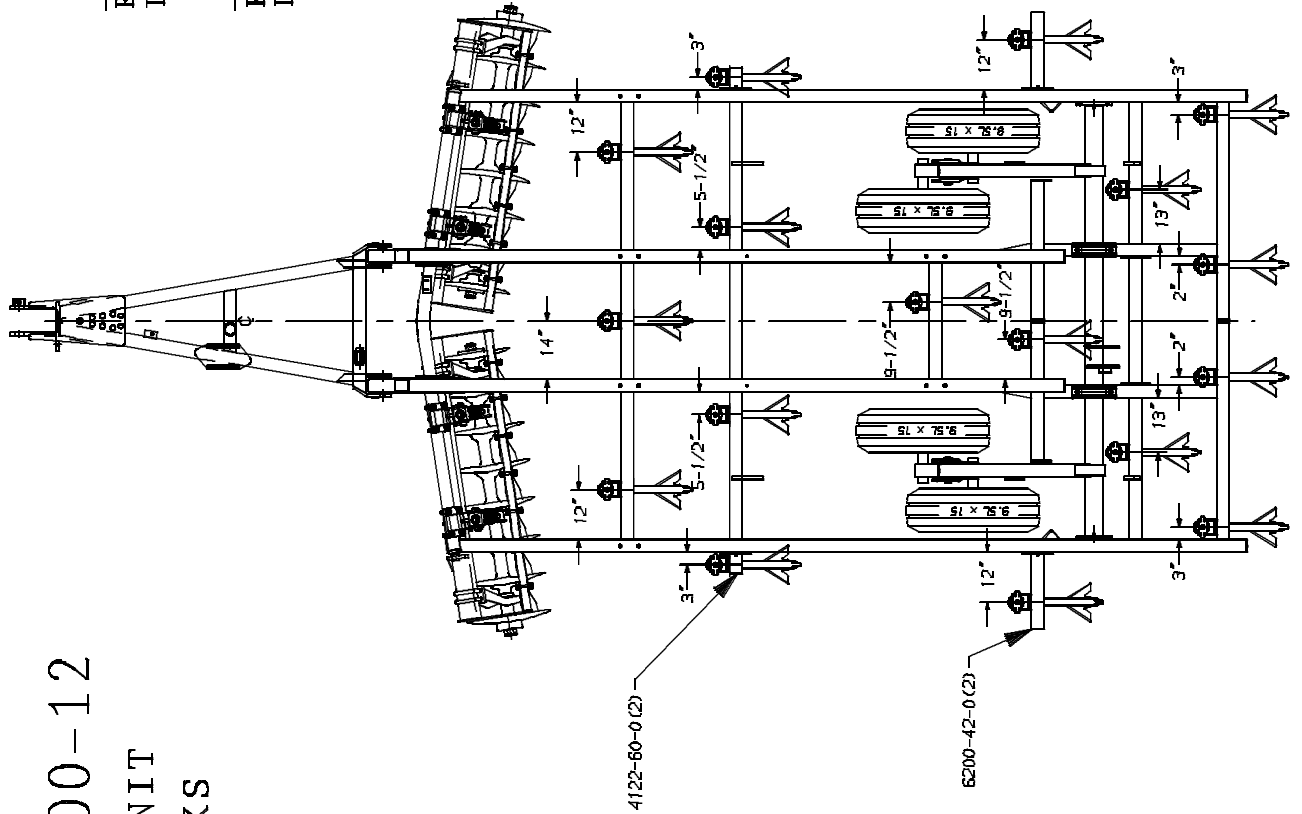

MODEL TL 6200-12
 9" SPACING UNIT
 2-PC K-TINE SHANKS

TIE RODS	
RIGHT CENTER	2212-18-1
LEFT CENTER	2212-18-1
GANG BEAMS	
RIGHT CENTER	6112-46-0
LEFT CENTER	6112-47-0

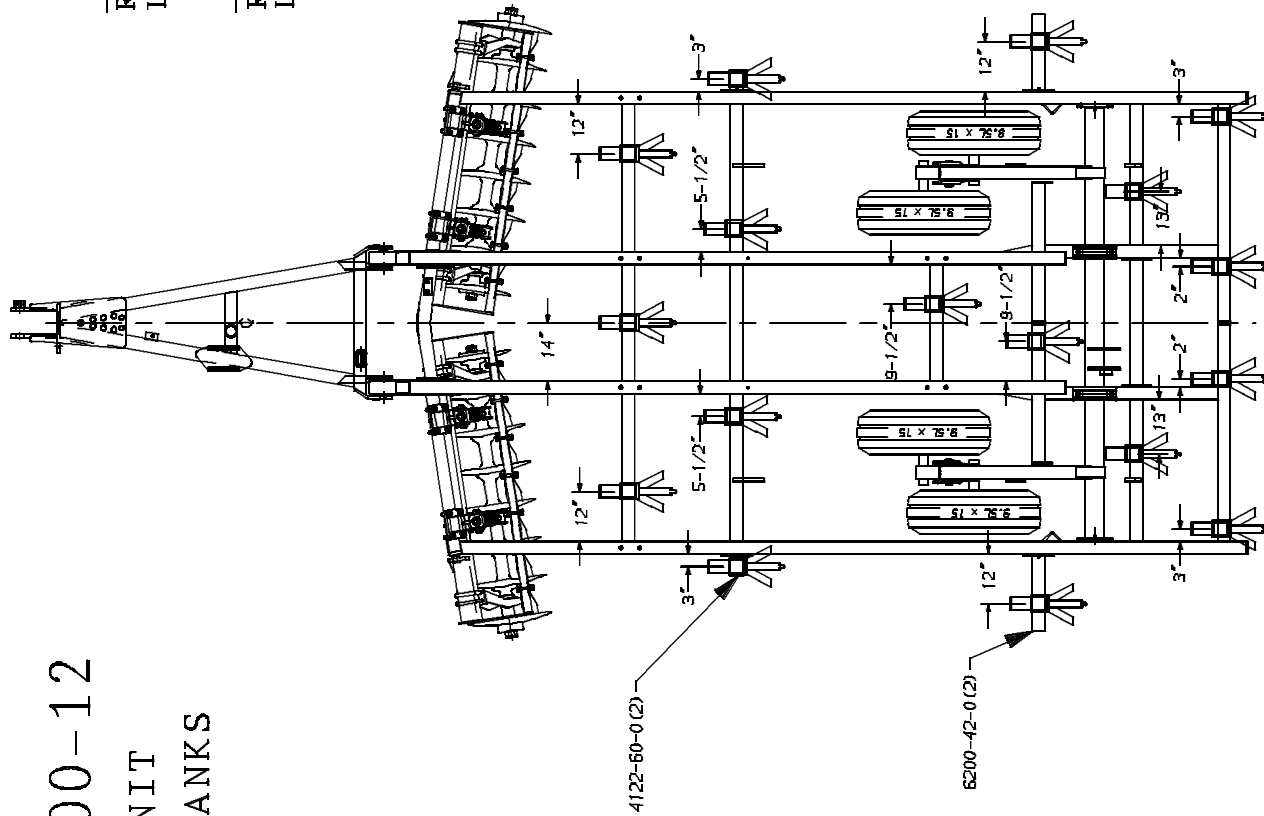

MODEL TL 6200-12
 9" SPACING UNIT
 XT 270 SHANKS

TIE RODS	
RIGHT CENTER	2212-18-1
LEFT CENTER	2212-18-1
GANG BEAMS	
RIGHT CENTER	6112-46-0
LEFT CENTER	6112-47-0

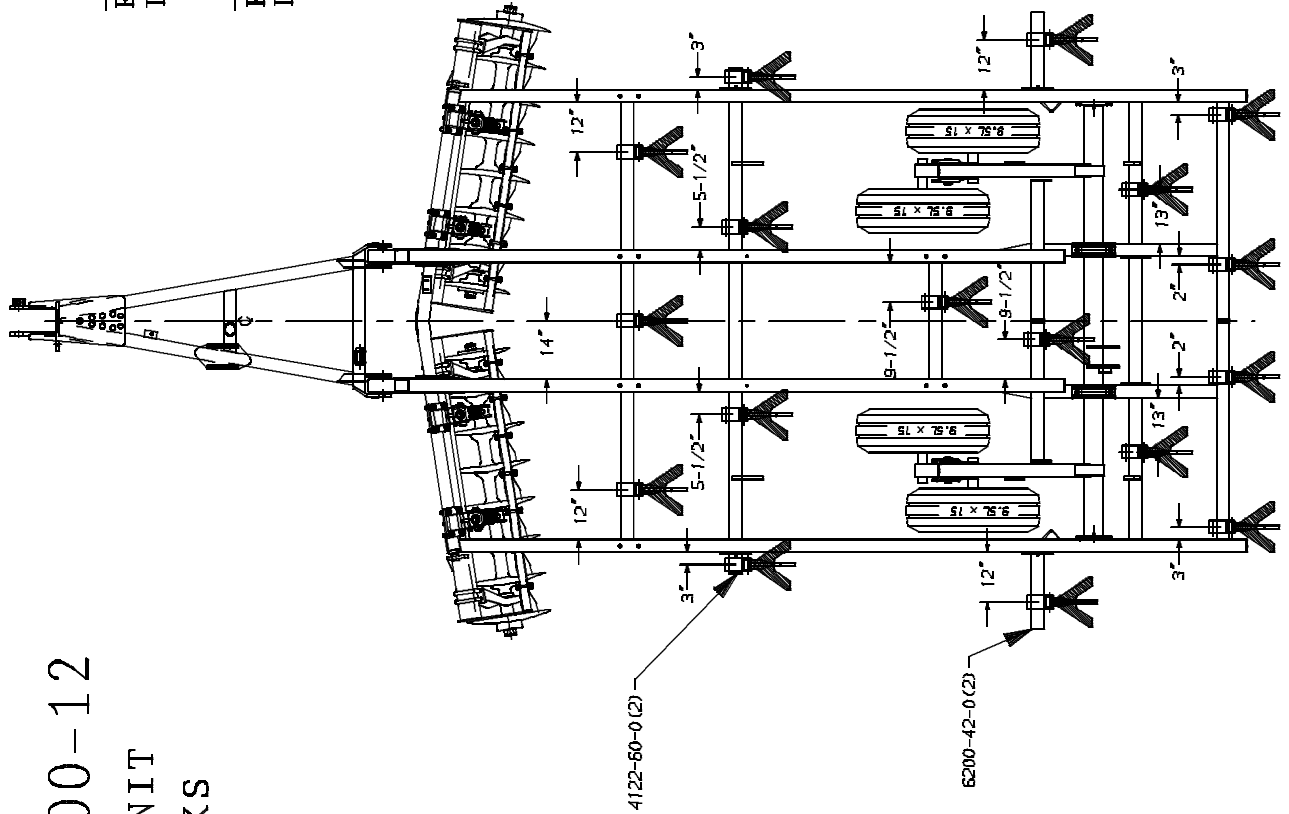

MODEL TL 6200-15
 7" SPACING UNIT
 SPRING SHANKS

TIE RODS	
RIGHT CENTER	2225-18-1
LEFT CENTER	2225-18-1
GANG BEAMS	
RIGHT CENTER	6115-53-0
LEFT CENTER	6115-52-0

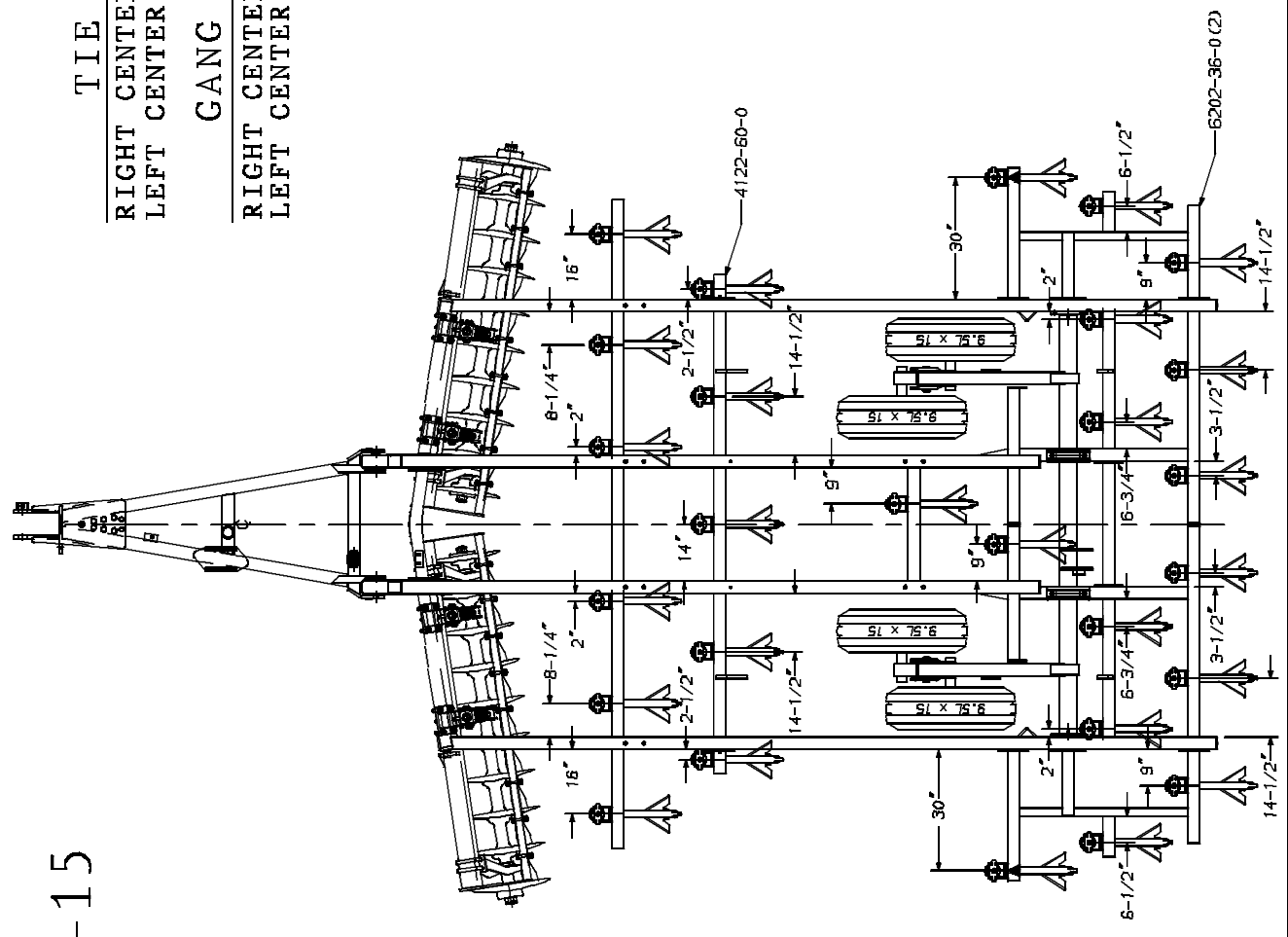

MODEL TL 6200-15
 7" SPACING UNIT
 2-PC K-TINE SHANKS

TIE RODS	
RIGHT CENTER	2225-18-1
LEFT CENTER	2225-18-1
GANG BEAMS	
RIGHT CENTER	6115-53-0
LEFT CENTER	6115-52-0

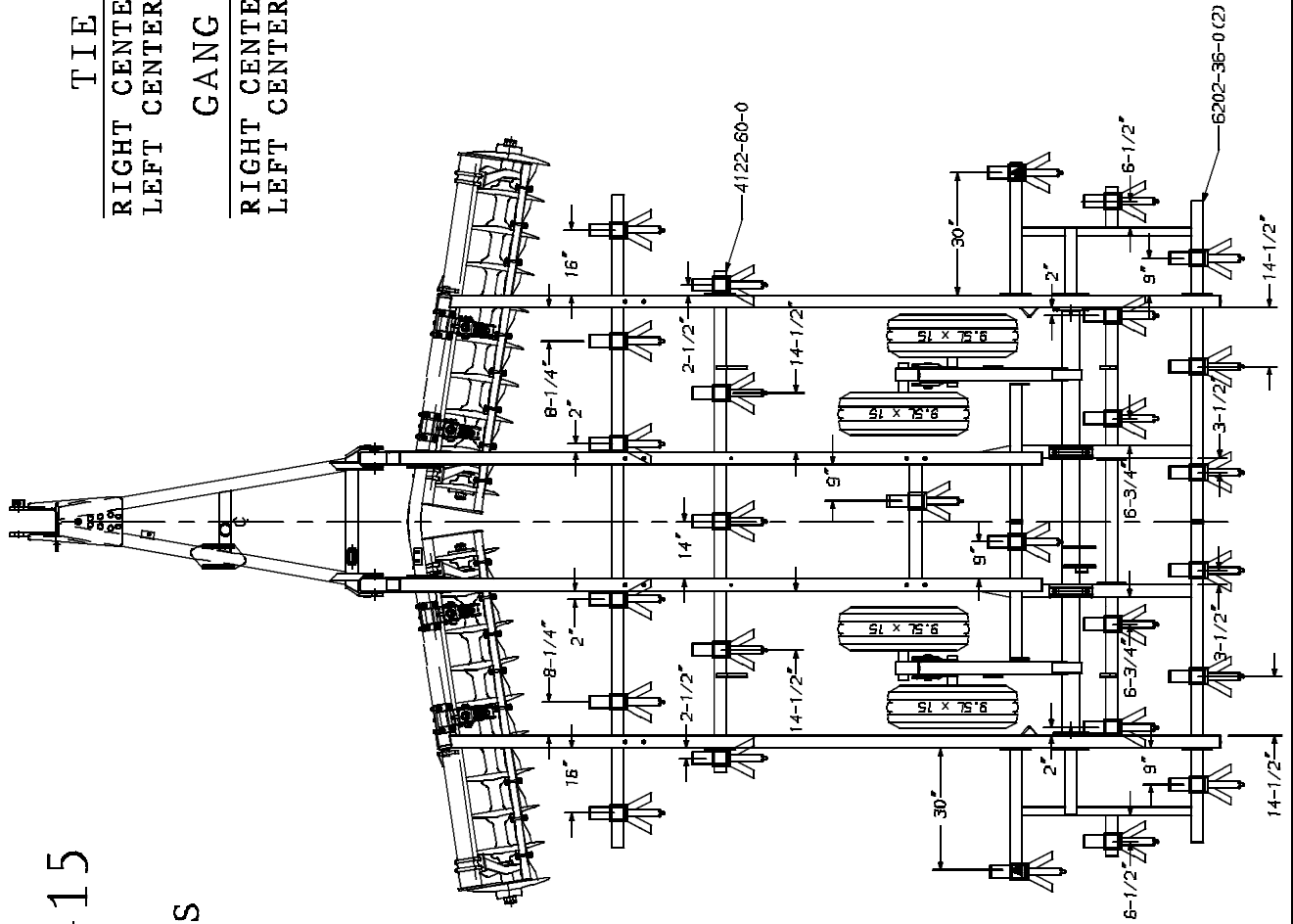

MODEL TL 6200-15
 9" SPACING UNIT
 SPRING SHANKS

TIE RODS	
RIGHT CENTER	2225-18-1
LEFT CENTER	2225-18-1
GANG BEAMS	
RIGHT CENTER	6115-53-0
LEFT CENTER	6115-52-0

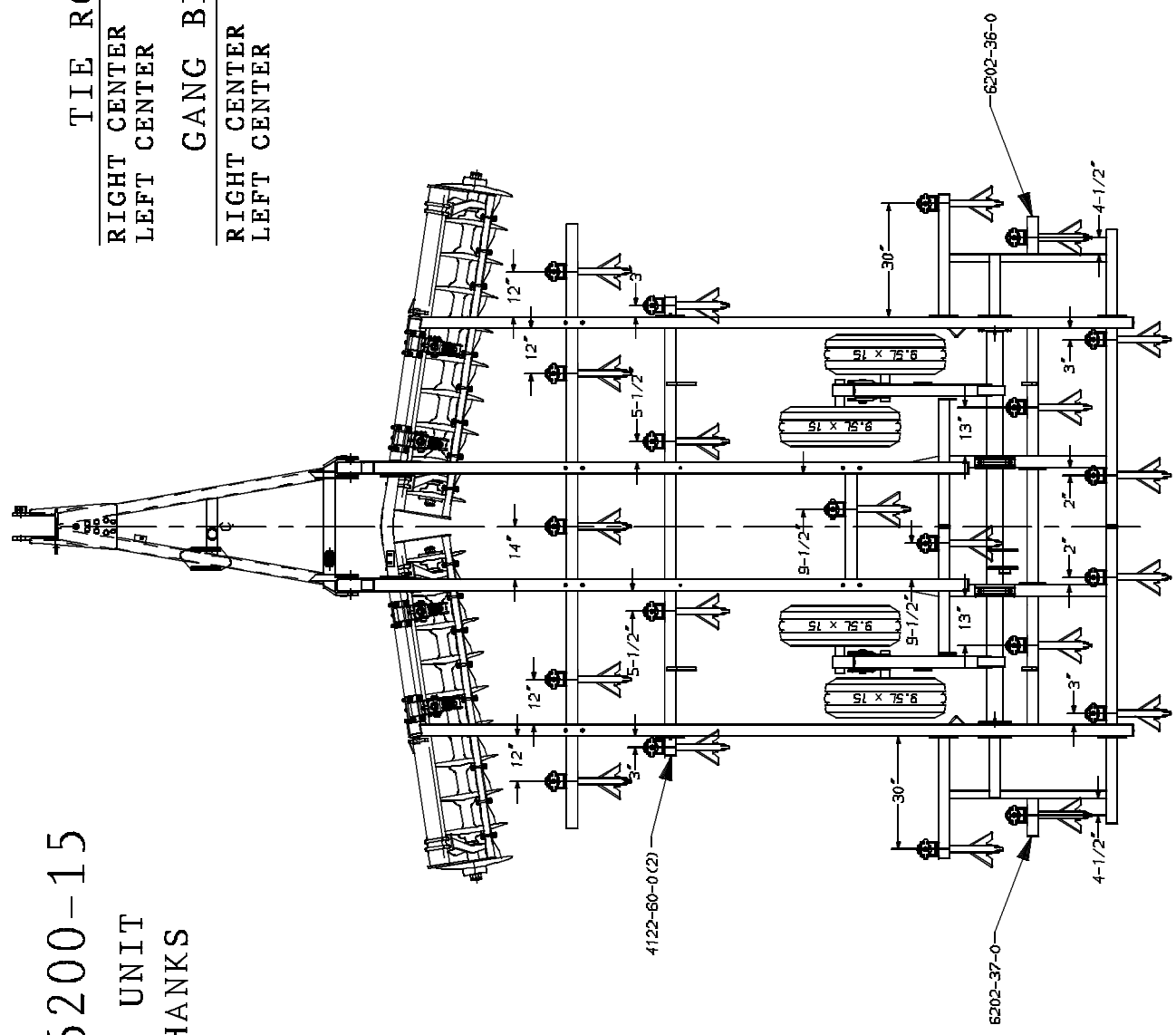

MODEL TL 6200-15

9" SPACING UNIT
2-PC K-TINE SHANKS

TIE RODS	
RIGHT CENTER	2225-18-1
LEFT CENTER	2225-18-1
GANG BEAMS	
RIGHT CENTER	6115-53-0
LEFT CENTER	6115-52-0

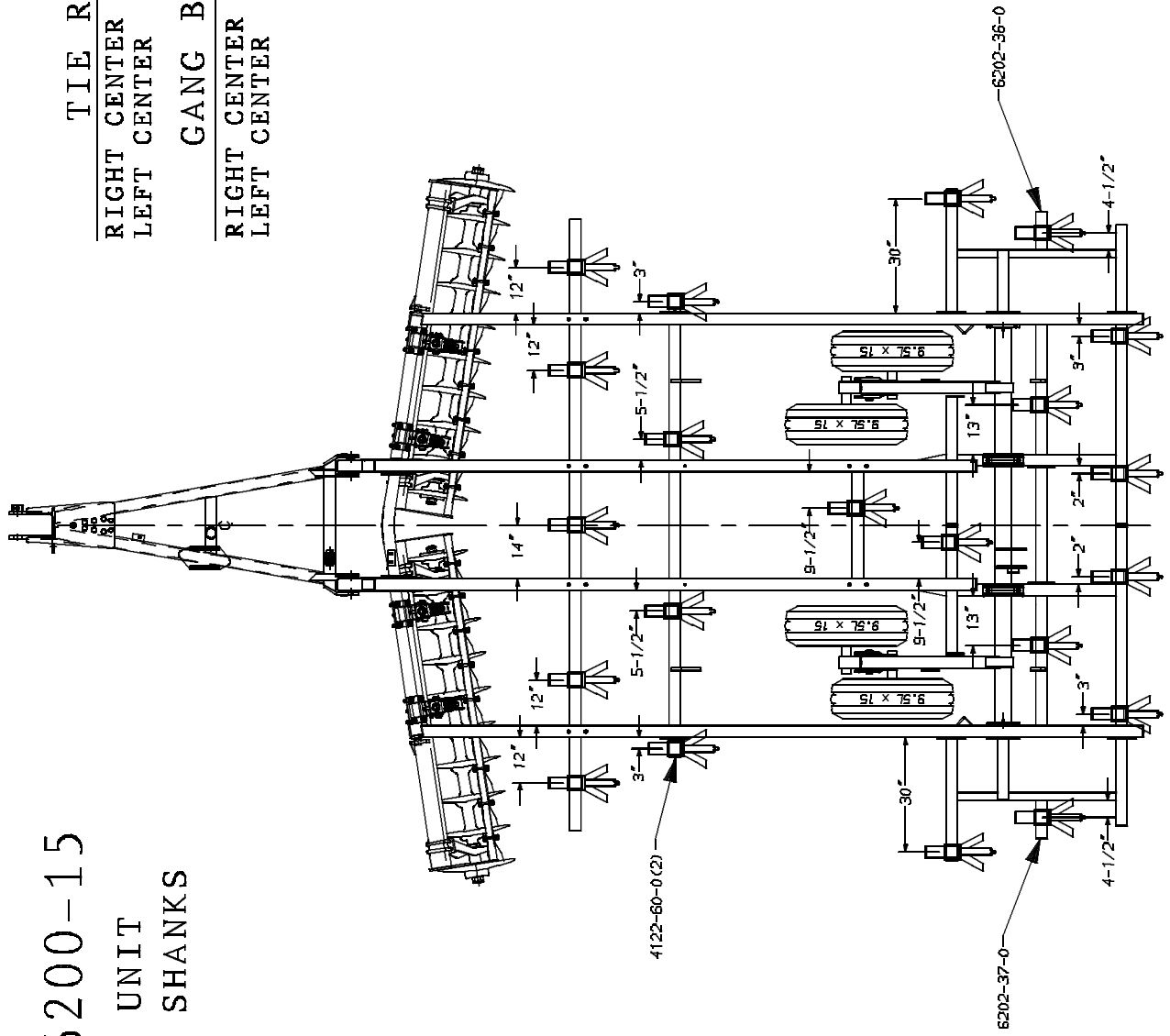

MODEL TL 6200-15
 9" SPACING UNIT
 XT 270 SHANKS

TIE RODS	
RIGHT CENTER	2225-18-1
LEFT CENTER	2225-18-1
GANG BEAMS	
RIGHT CENTER	6115-53-0
LEFT CENTER	6115-52-0

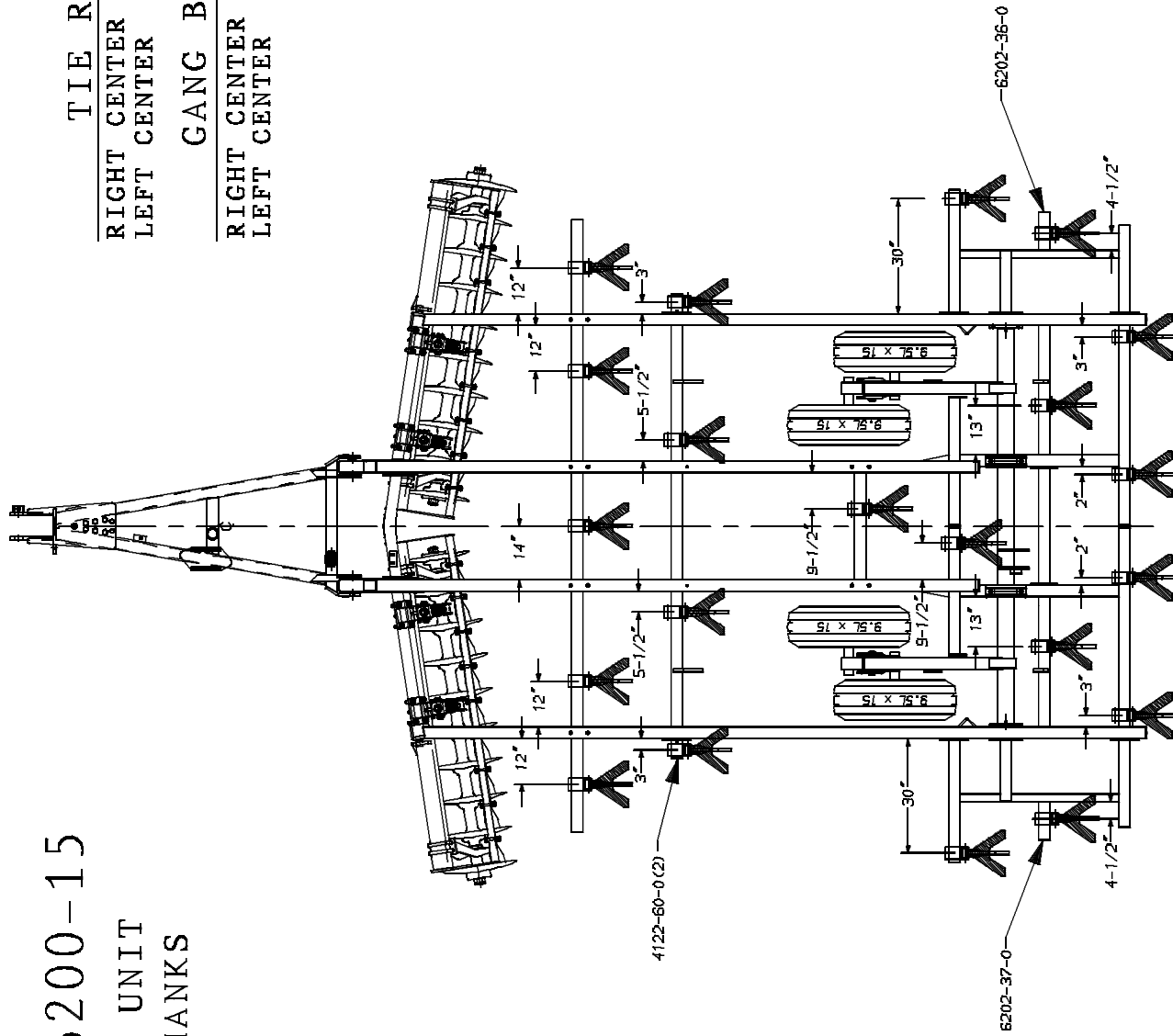

MODEL TL 6200-18

7" SPACING UNIT
SPRING SHANKS

TIE RODS	
RT & LT CENTER	2146-82-1
LT & RT WING	2146-82-1
GANG BEAMS	
RIGHT CENTER	6118-52-0
LEFT CENTER	6118-53-0
RIGHT WING	3118-46-0
LEFT WING	3118-46-0

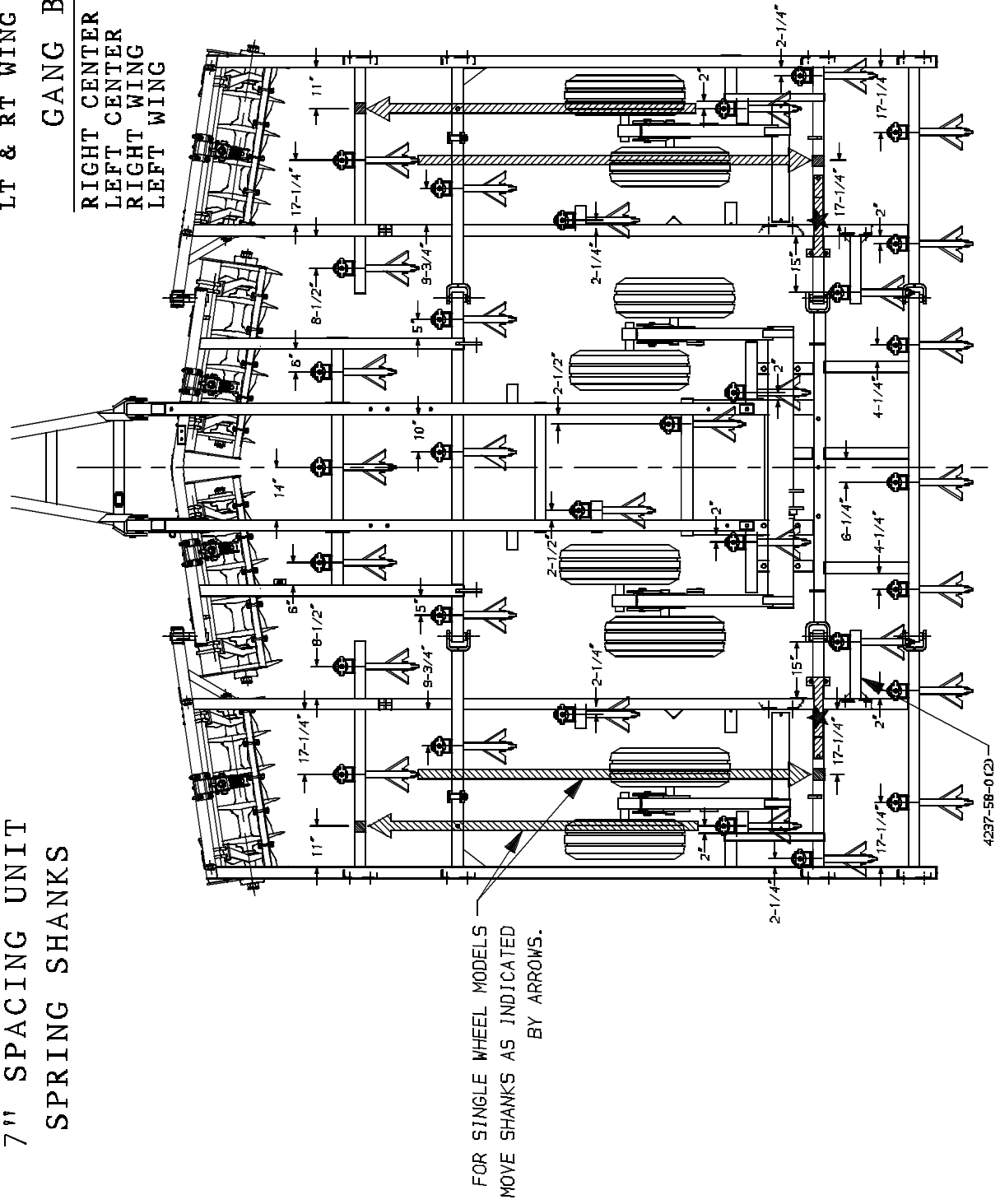

MODEL TL 6200-18

7" SPACING UNIT
2-PC K-TINE SHANKS

TIE RODS

RT & LT CENTER	2146-82-1
LT & RT WING	2146-82-1

GANG BEAMS

RIGHT CENTER	6118-52-0
LEFT CENTER	6118-53-0
RIGHT WING	3118-46-0
LEFT WING	3118-46-0

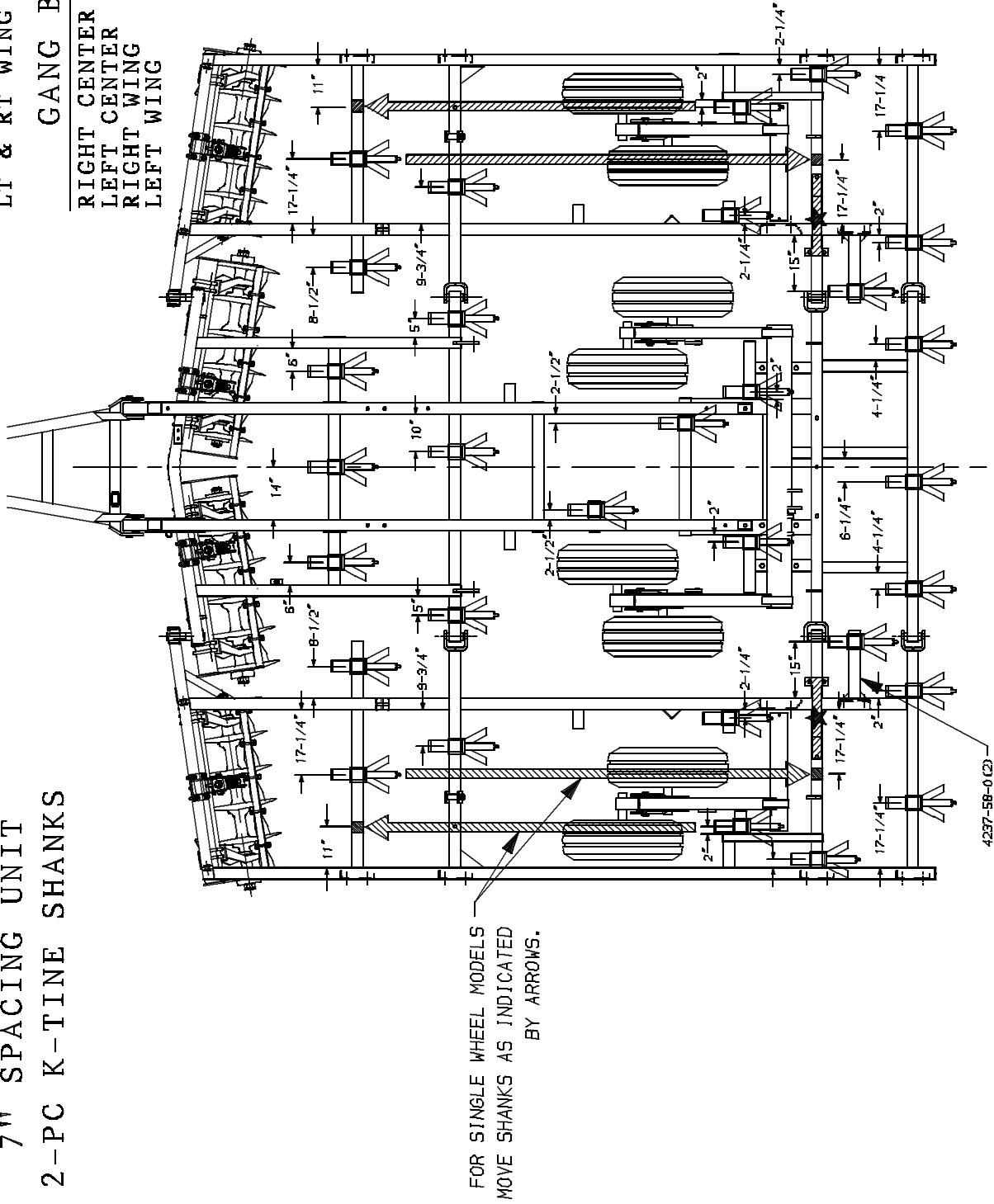

MODEL TL 6200-18

9" SPACING UNIT SPRING SHANKS

NOTE: UNITS WITH SINGLE WHEELS ON WINGS
USE SAME SHANK LOCATIONS AS SHOWN

TIE RODS	
RT & LT CENTER	2146-82-1
RT & LT WING	2146-82-1
GANG BEAMS	
RIGHT CENTER	6118-52-0
LEFT CENTER	6118-53-0
RT & LT WING	3118-46-0

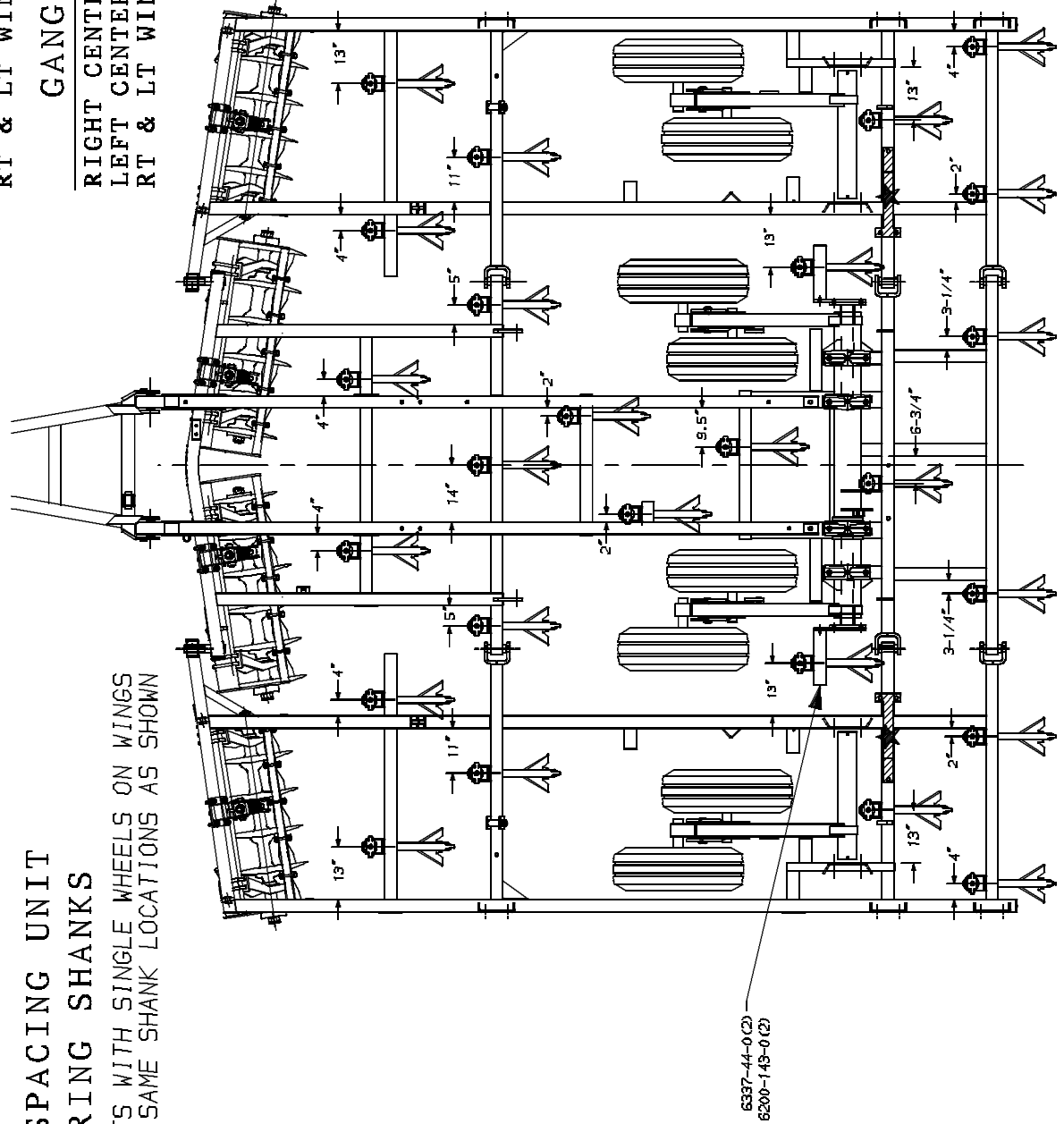

MODEL TL 6200-18

9" SPACING UNIT 2-PC K-TINE SHANKS

NOTE: UNITS WITH SINGLE WHEELS ON WINGS
USE SAME SHANK LOCATIONS AS SHOWN

TIE RODS
RT & LT CENTER 2146-82-1
RT & LT WING 2146-82-1

GANG BEAMS
RIGHT CENTER 6118-52-0
LEFT CENTER 6118-53-0
RT & LT WING 3118-46-0

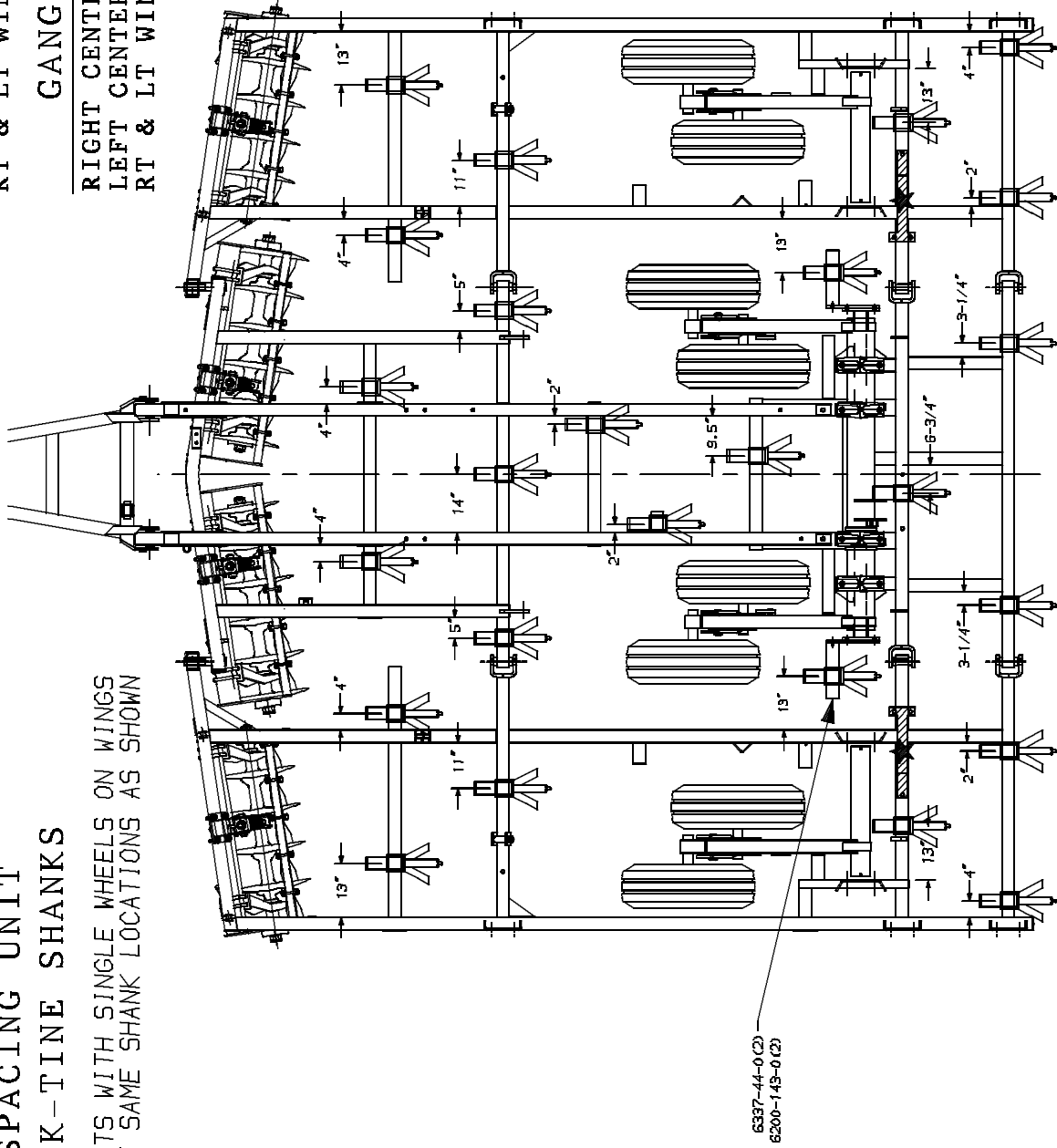

MODEL TL 6200-18

9" SPACING UNIT

XT 270 SHANKS

NOTE: UNITS WITH SINGLE WHEELS ON WINGS
USE SAME SHANK LOCATIONS AS SHOWN

TIE RODS

RT & LT CENTER	2146-82-1
RT & LT WING	2146-82-1

GANG BEAMS

RIGHT CENTER	6118-52-0
LEFT CENTER	6118-53-0
RT & LT WING	3118-46-0

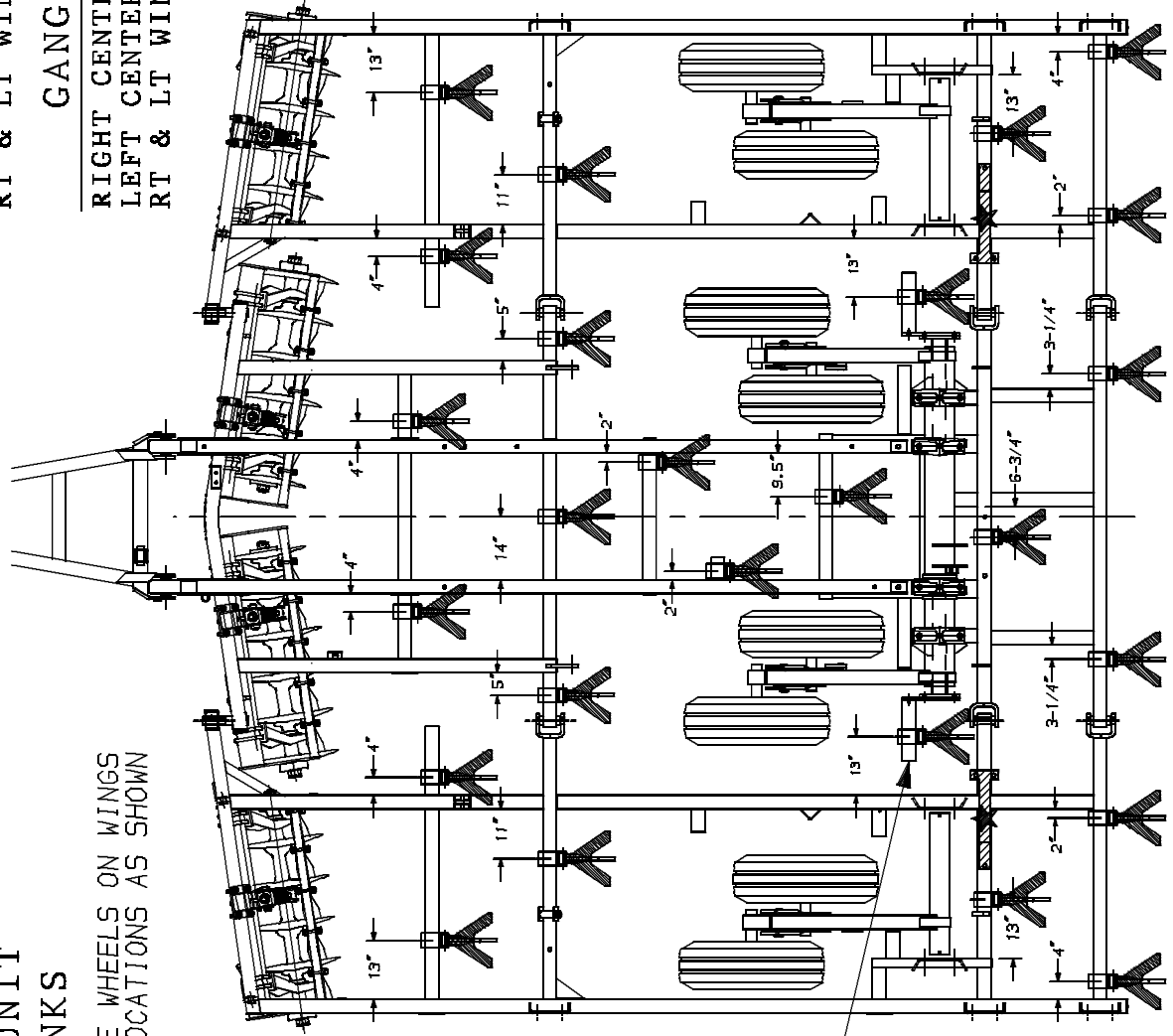

6200-145-0 (2)
6200-143-0 (2)

MODEL TL 6200-21

7" SPACING UNIT

SPRING SHANKS

TIE RODS	
RT & LT CENTER	2146-82-1
RT & LT WING	2136-82-1

GANG BEAMS	
RIGHT CENTER	6118-52-0
LEFT CENTER	6118-53-0
RIGHT WING	6121-48-0
LEFT WING	6121-49-0

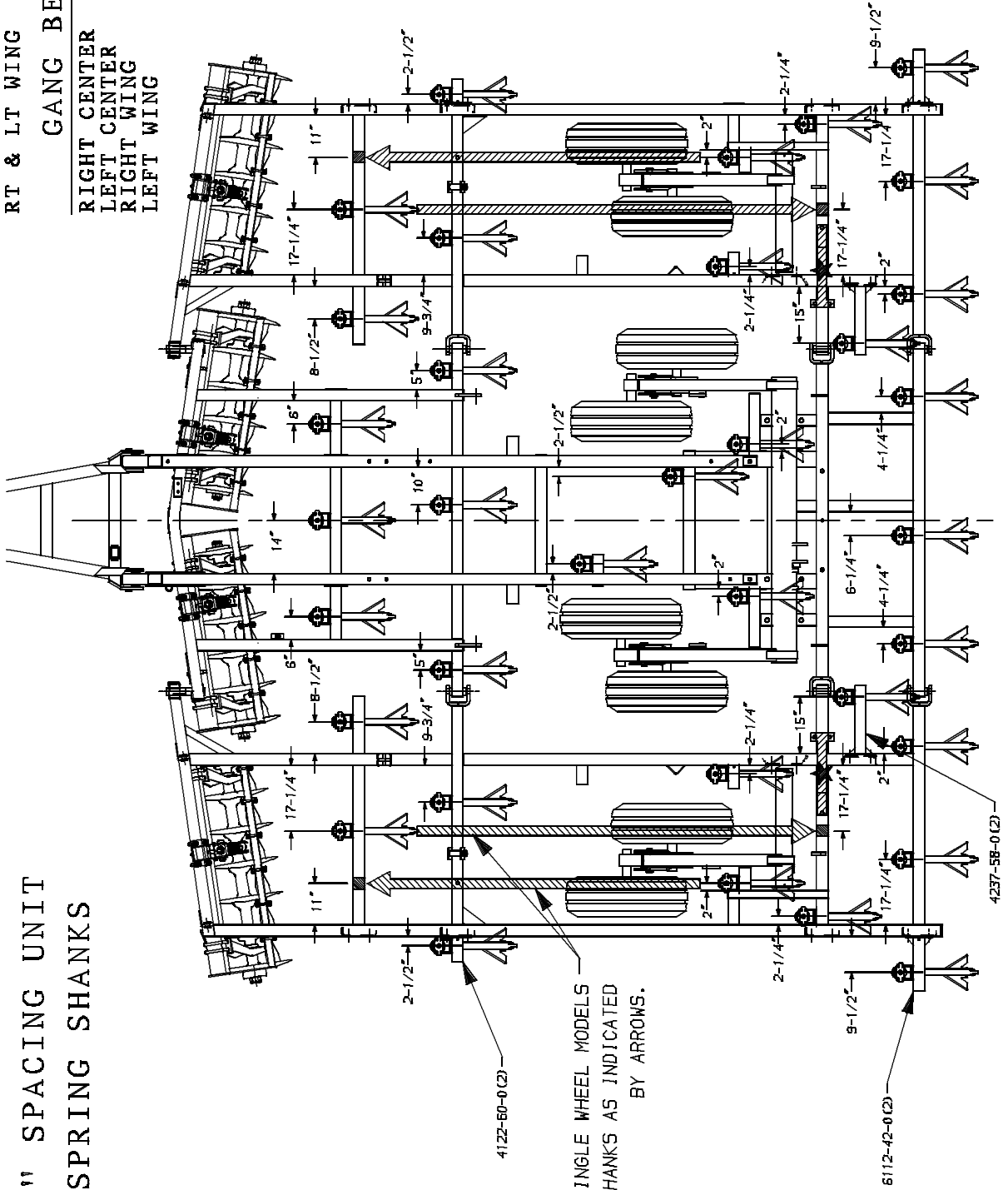

MODEL TL 6200-21

9" SPACING UNIT SPRING SHANKS

TIE RODS	
RT & LT CENTER	2146-82-1
RT & LT WING	2136-82-1
GANG BEAMS	
RIGHT CENTER	6118-52-0
LEFT CENTER	6118-53-0
RIGHT WING	6121-48-0
LEFT WING	6121-49-0

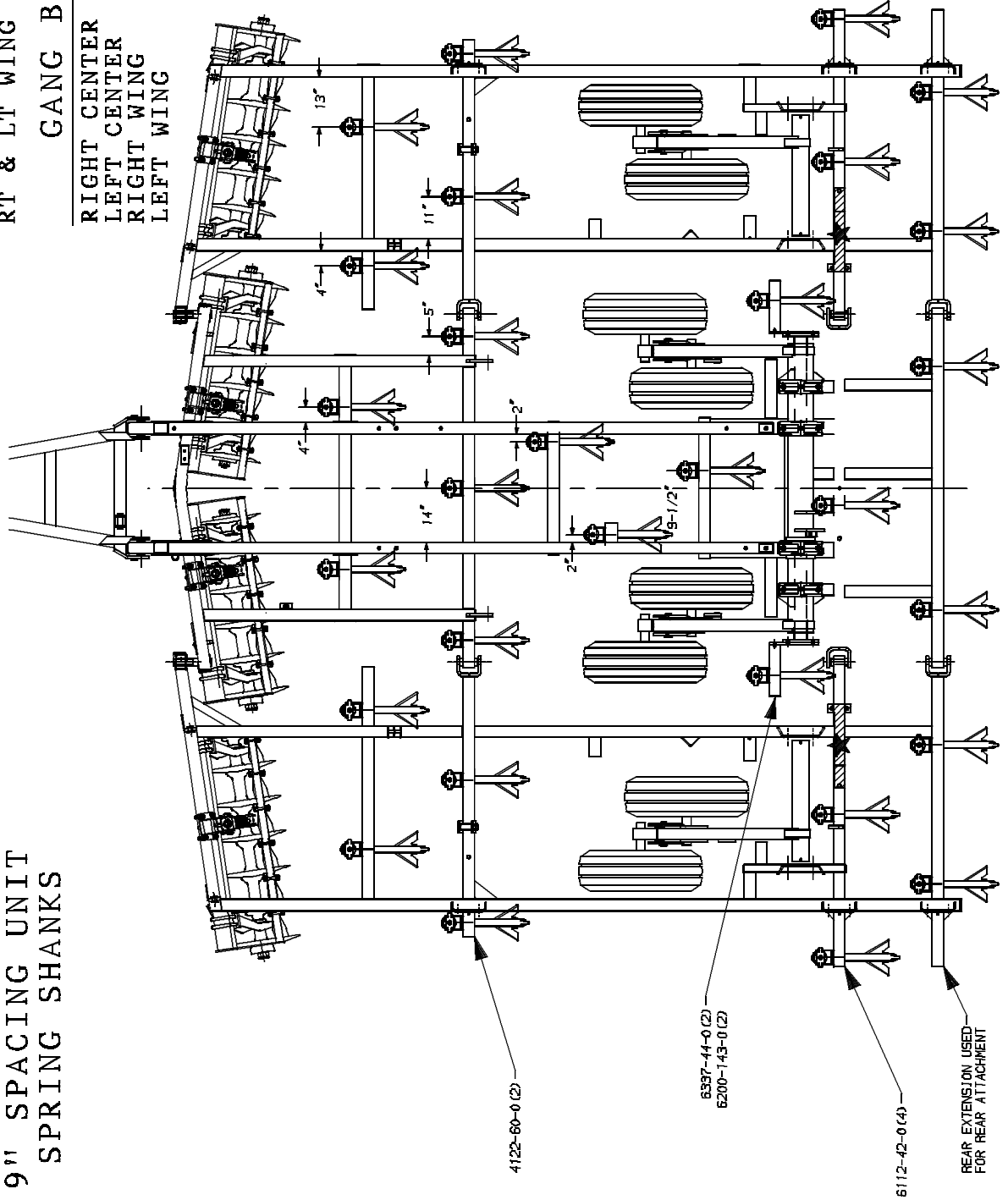

MODEL TL 6200-21

9" SPACING UNIT
2-PC K-TINE SHANKS

NOTE: UNITS WITH SINGLE WHEELS ON WINGS
USE SAME SHANK LOCATIONS AS SHOWN

TIE RODS	
RT & LT CENTER	2146-82-1
RT & LT WING	2136-82-1

GANG BEAMS	
RIGHT CENTER	6118-52-0
LEFT CENTER	6118-53-0
RIGHT WING	6121-48-0
LEFT WING	6121-49-0

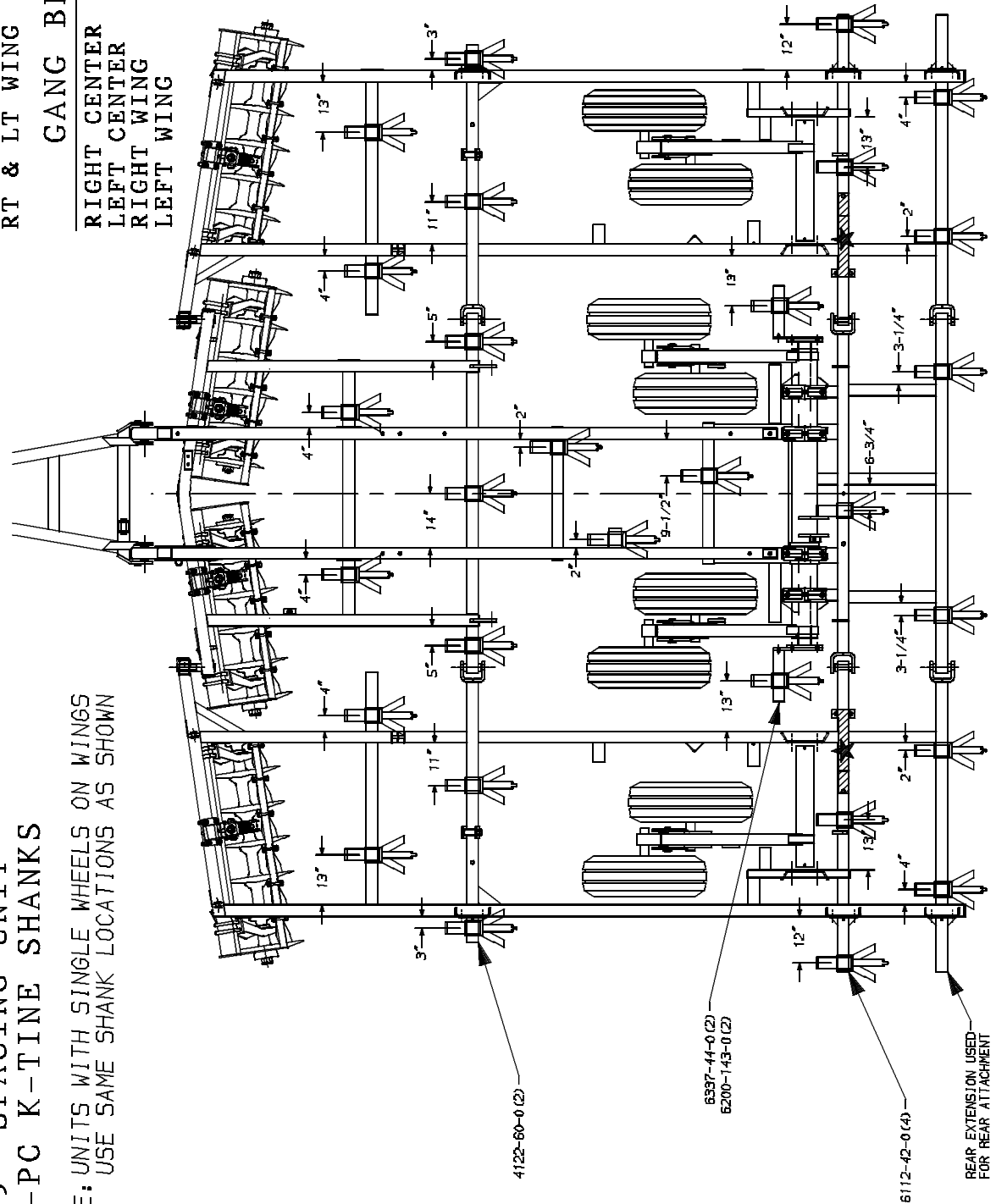

MODEL TL 6200-24

7" SPACING UNIT
SPRING SHANKS

TIE RODS

RT & LT CENTER 2146-82-1
RT & LT WING 2225-18-1

GANG BEAMS

RIGHT CENTER 6118-52-0
LEFT CENTER 6118-53-0
RT & LT WING 6127-70-0

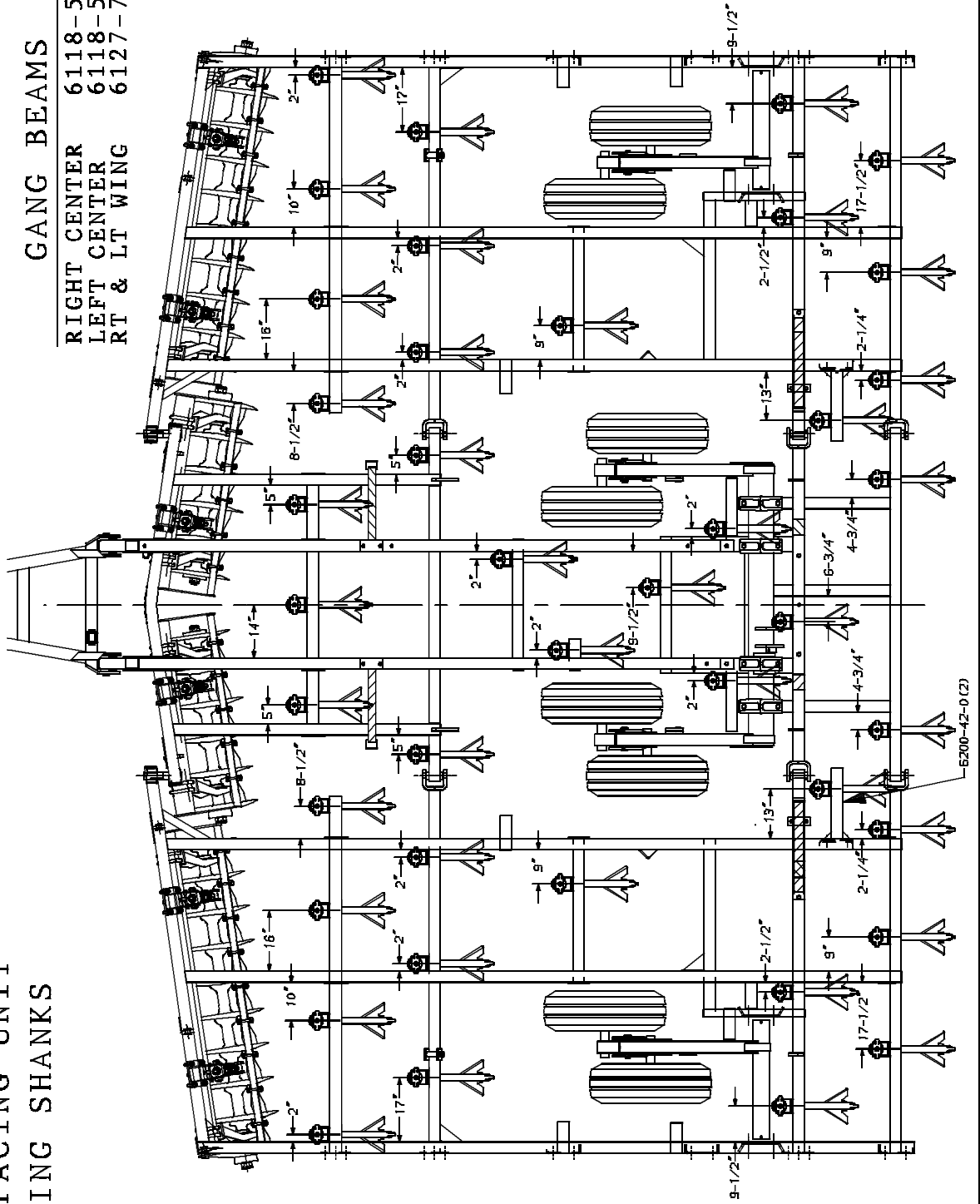

MODEL TL 6200-24

7" SPACING UNIT
2-PC K-TINE SHANKS

TIE RODS

RT & LT CENTER 2146-82-1
RT & LT WING 2225-18-1

GANG BEAMS

RIGHT CENTER 6118-52-0
LEFT CENTER 6118-53-0
RT & LT WING 6127-70-0

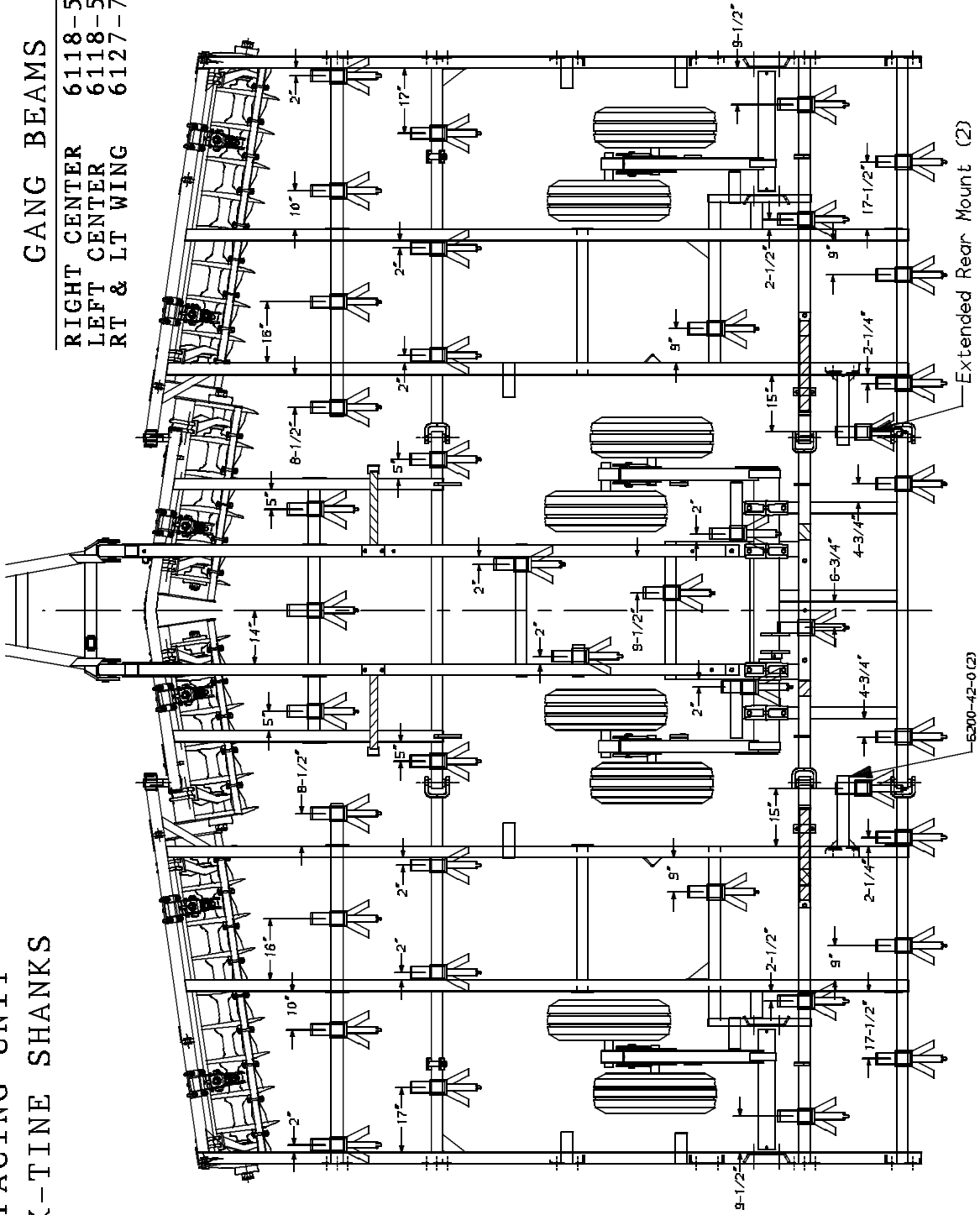

MODEL TL 6200-24
 9" SPACING UNIT
 SPRING SHANKS

TIE RODS	
RT & LT CENTER	2145-82-1
RT & LT WING	2225-18-1
GANG BEAMS	
RIGHT CENTER	6118-52-0
LEFT CENTER	6118-53-0
RT & LT WING	6127-70-0

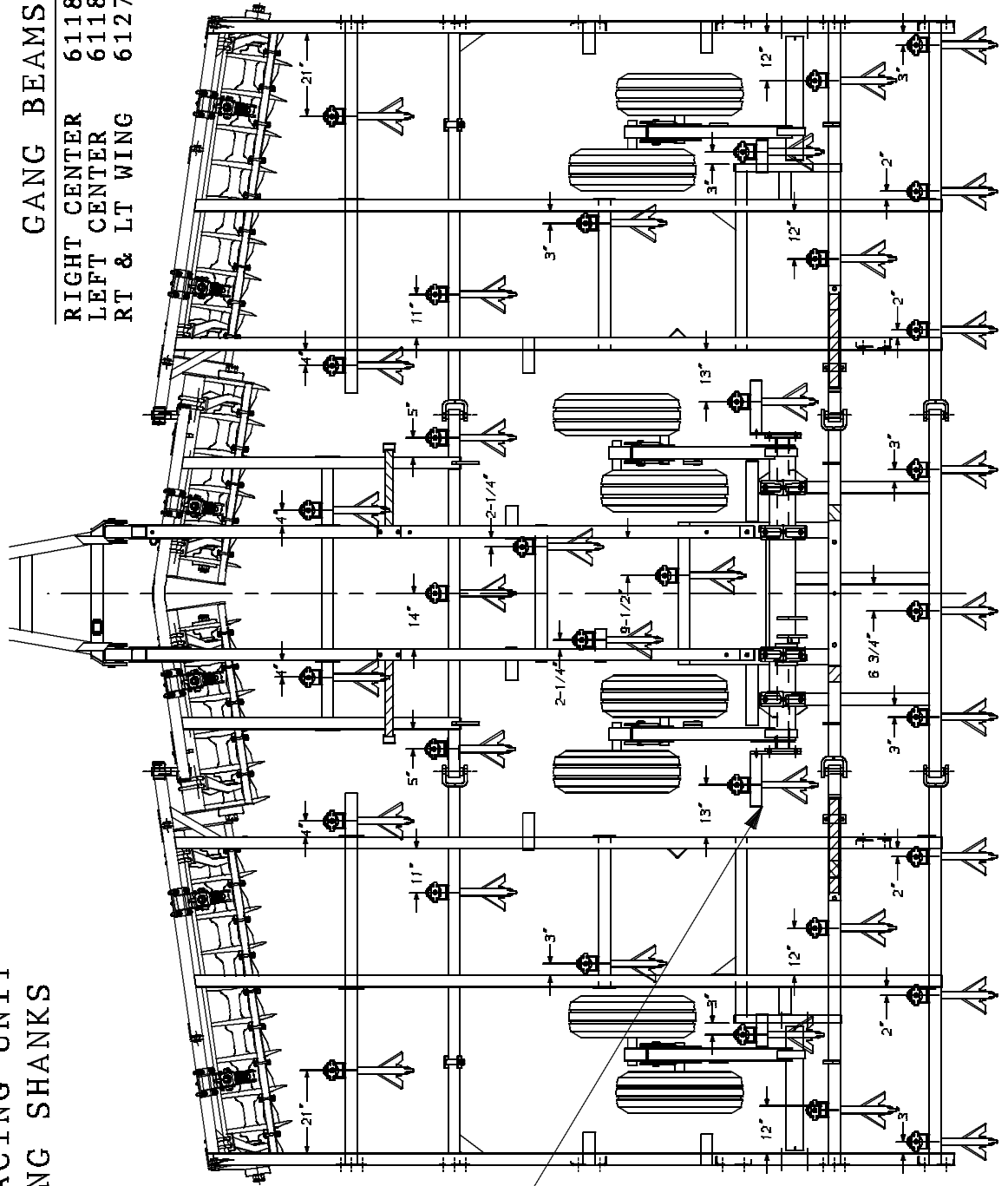

5337-44-0 (2)
 5200-143-0 (2)

MODEL TL 6200-24

9" SPACING UNIT
2-PC K-TINE SHANKS

TIE RODS
RT & LT CENTER 2145-82-1
RT & LT WING 2225-18-1

GANG BEAMS
RIGHT CENTER 6118-52-0
LEFT CENTER 6118-53-0
RT & LT WING 6127-70-0

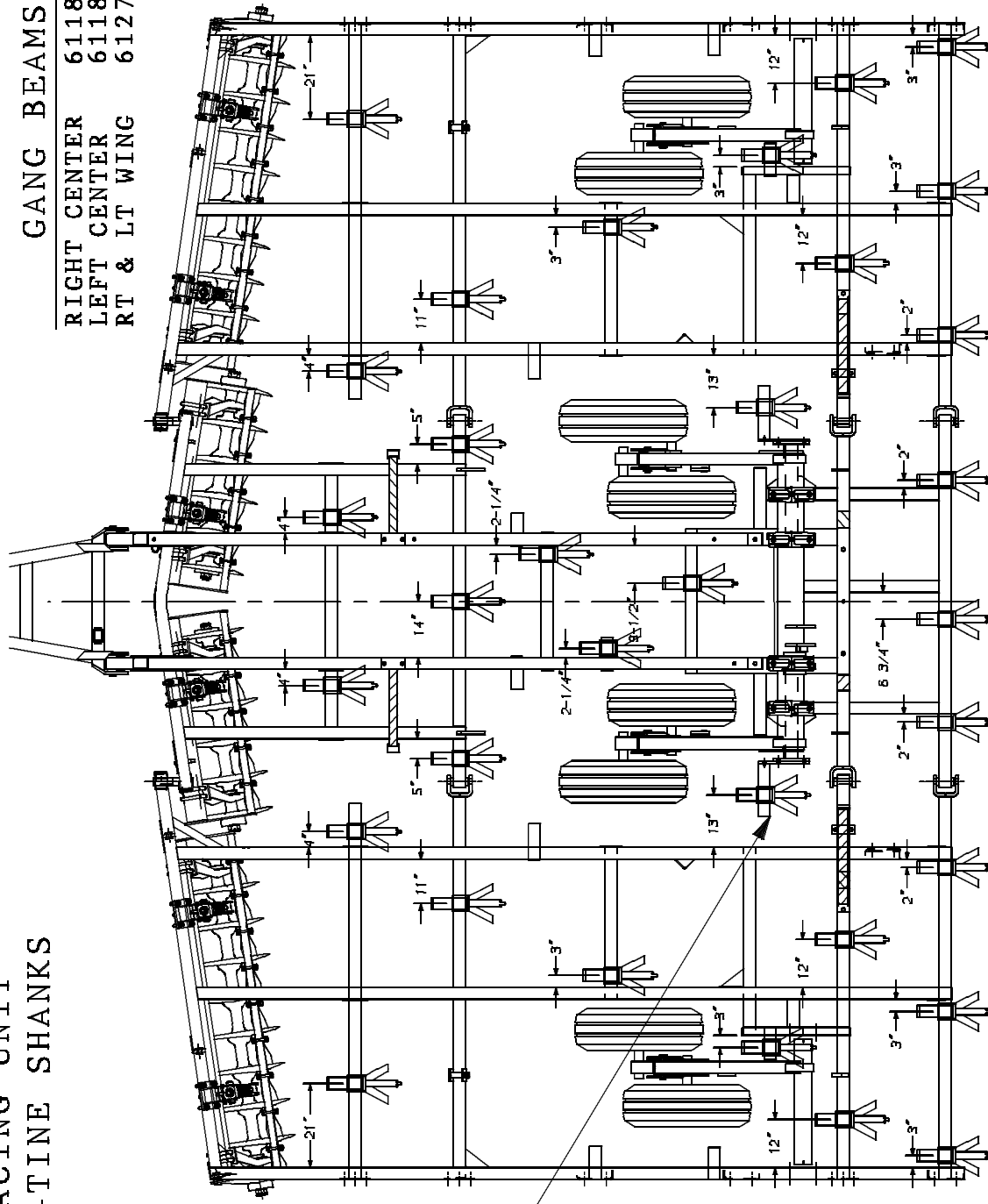

5337-44-0 (2)
5200-143-0 (2)

MODEL TL 6200-24

9" SPACING UNIT
XT 270 SHANKS

TIE RODS
RT & LT CENTER 2145-82-1
RT & LT WING 2225-18-1

GANG BEAMS
RIGHT CENTER 6118-52-0
LEFT CENTER 6118-53-0
RT & LT WING 6127-70-0

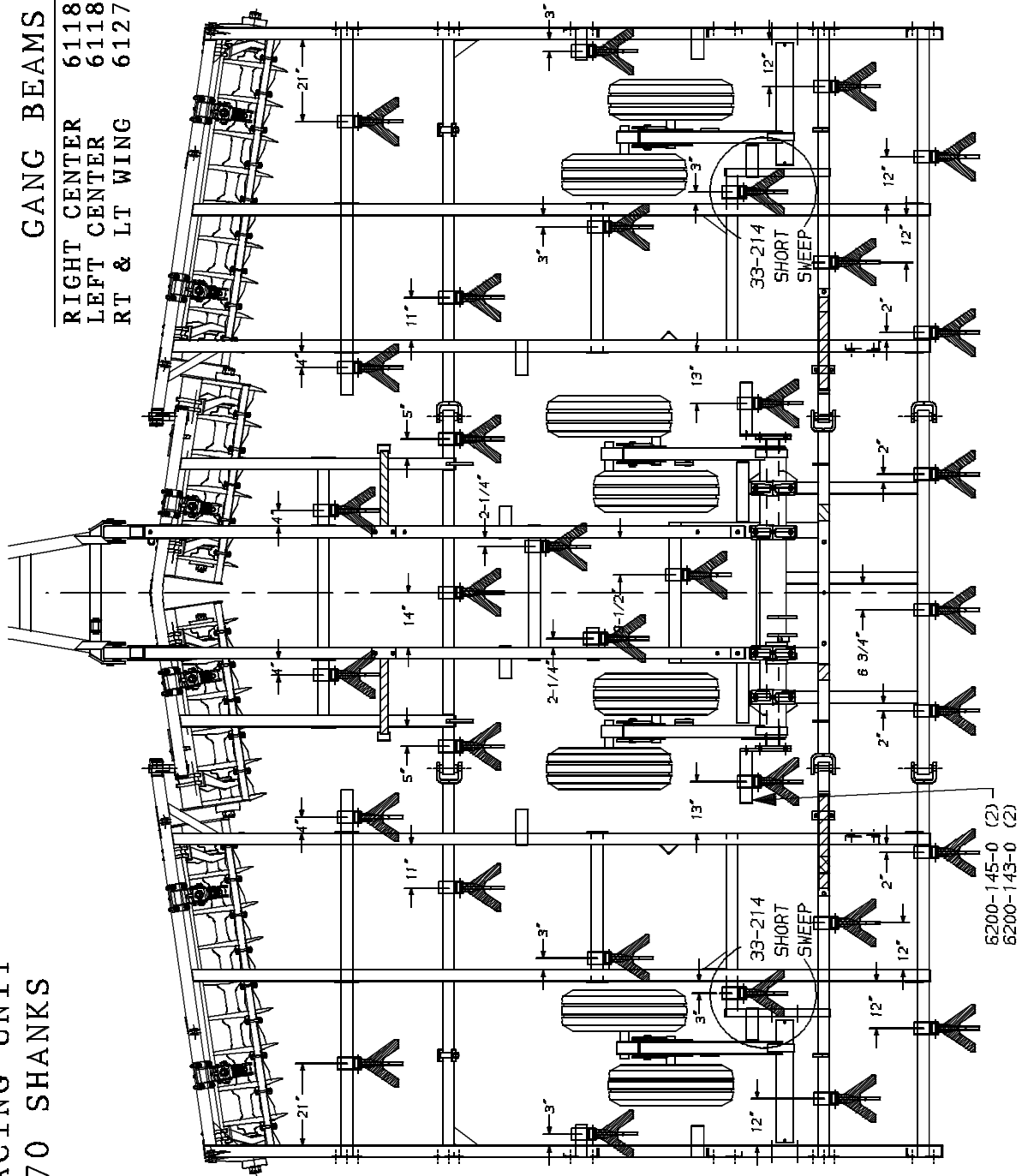

MODEL TL 6200-27

7" SPACING UNIT
SPRING SHANKS

TIE RODS

RT & LT CENTER 2212-18-1
RT & LT WING 2225-18-1

GANG BEAMS

RIGHT CENTER 3112-46-0
LEFT CENTER 3112-47-0
RT & LT WING 6127-70-0

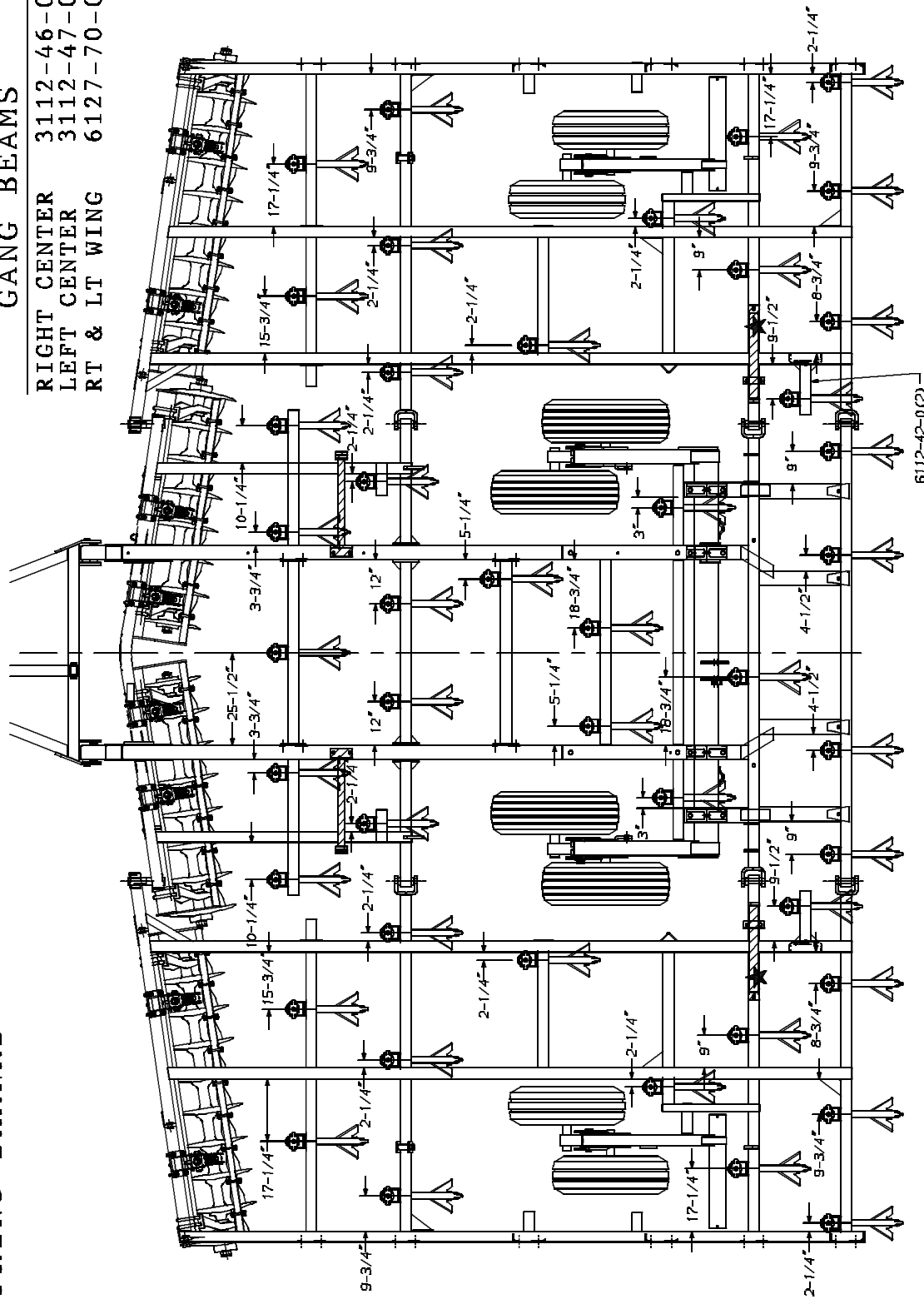

6112-42-0 (2)

MODEL TL 6200-27

9" SPACING UNIT
SPRING SHANKS

TIE RODS

RT & LT CENTER 2212-18-1
RT & LT WING 2225-18-1

GANG BEAMS

RIGHT CENTER 3112-46-0
LEFT CENTER 3112-47-0
RT & LT WING 6127-70-0

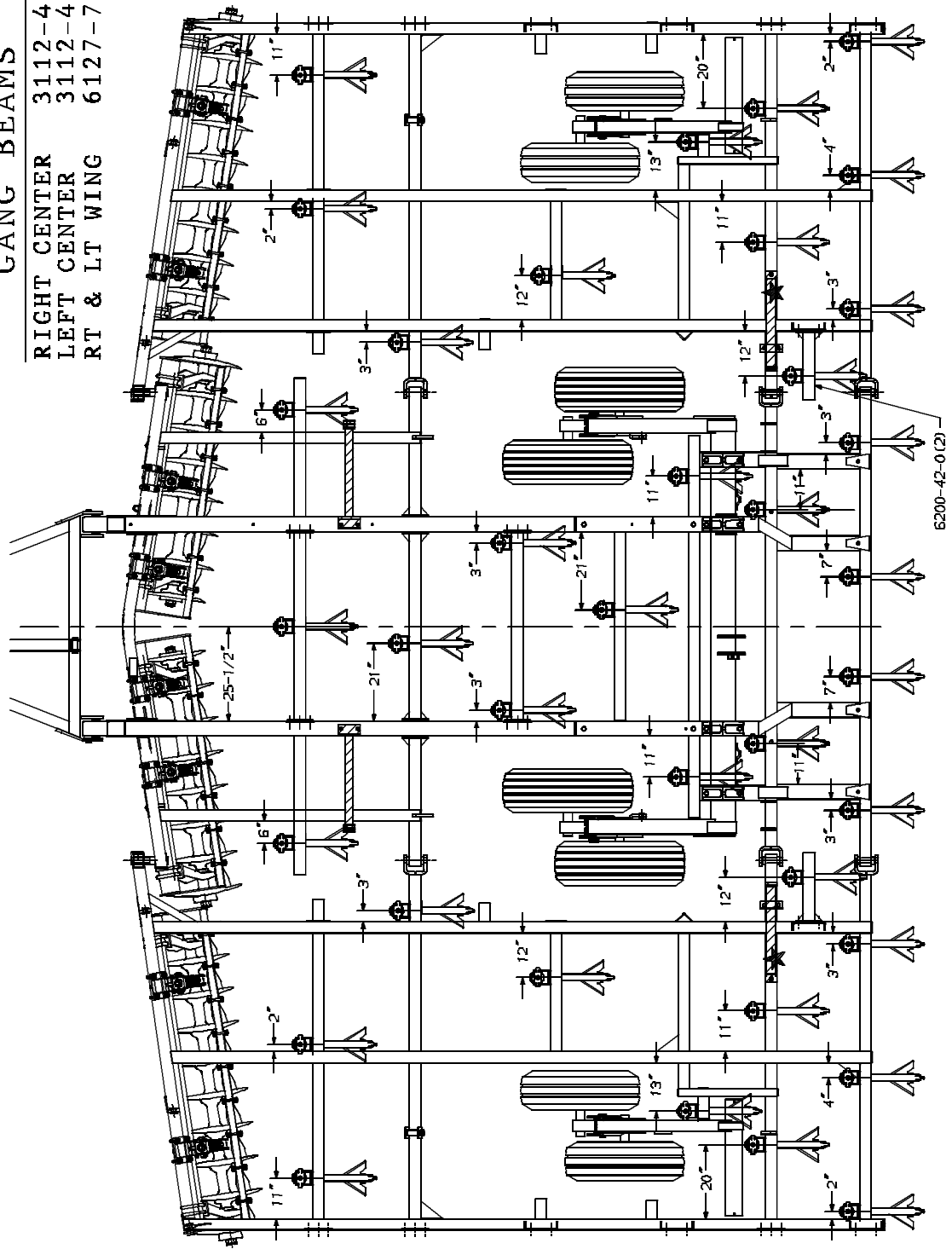

MODEL TL 6200-27

9" SPACING UNIT
2-PC K-TINE SHANKS

TIE RODS

RT & LT CENTER 2212-18-1
RT & LT WING 2225-18-1

GANG BEAMS

RIGHT CENTER 3112-46-0
LEFT CENTER 3112-47-0
RT & LT WING 6127-70-0

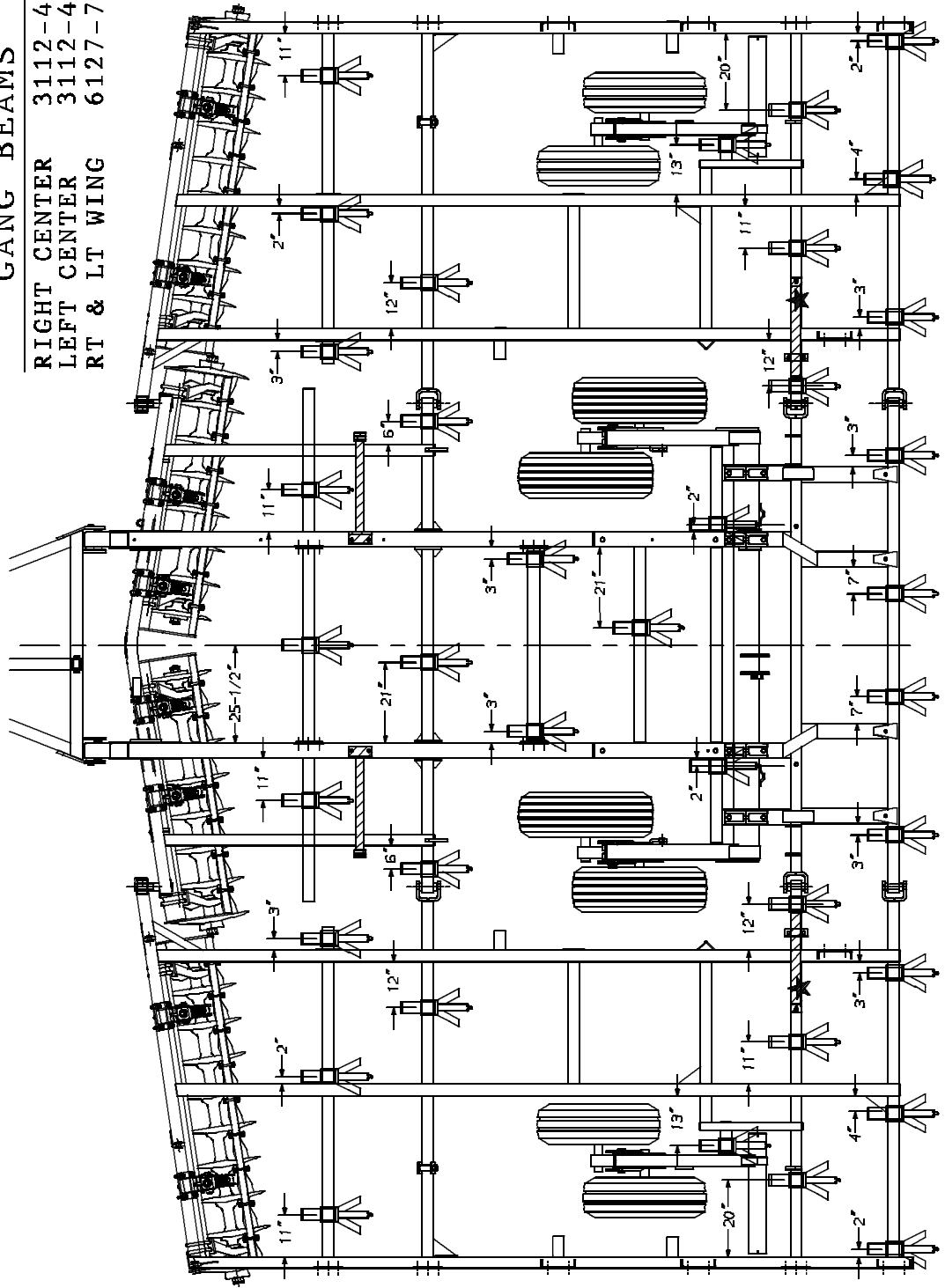

MODEL TL 6200-27

9" SPACING UNIT
XT 270 SHANKS

TIE RODS

RT & LT CENTER 2212-18-1
RT & LT WING 2225-18-1

GANG BEAMS

RIGHT CENTER 3112-46-0
LEFT CENTER 3112-47-0
RT & LT WING 6127-70-0

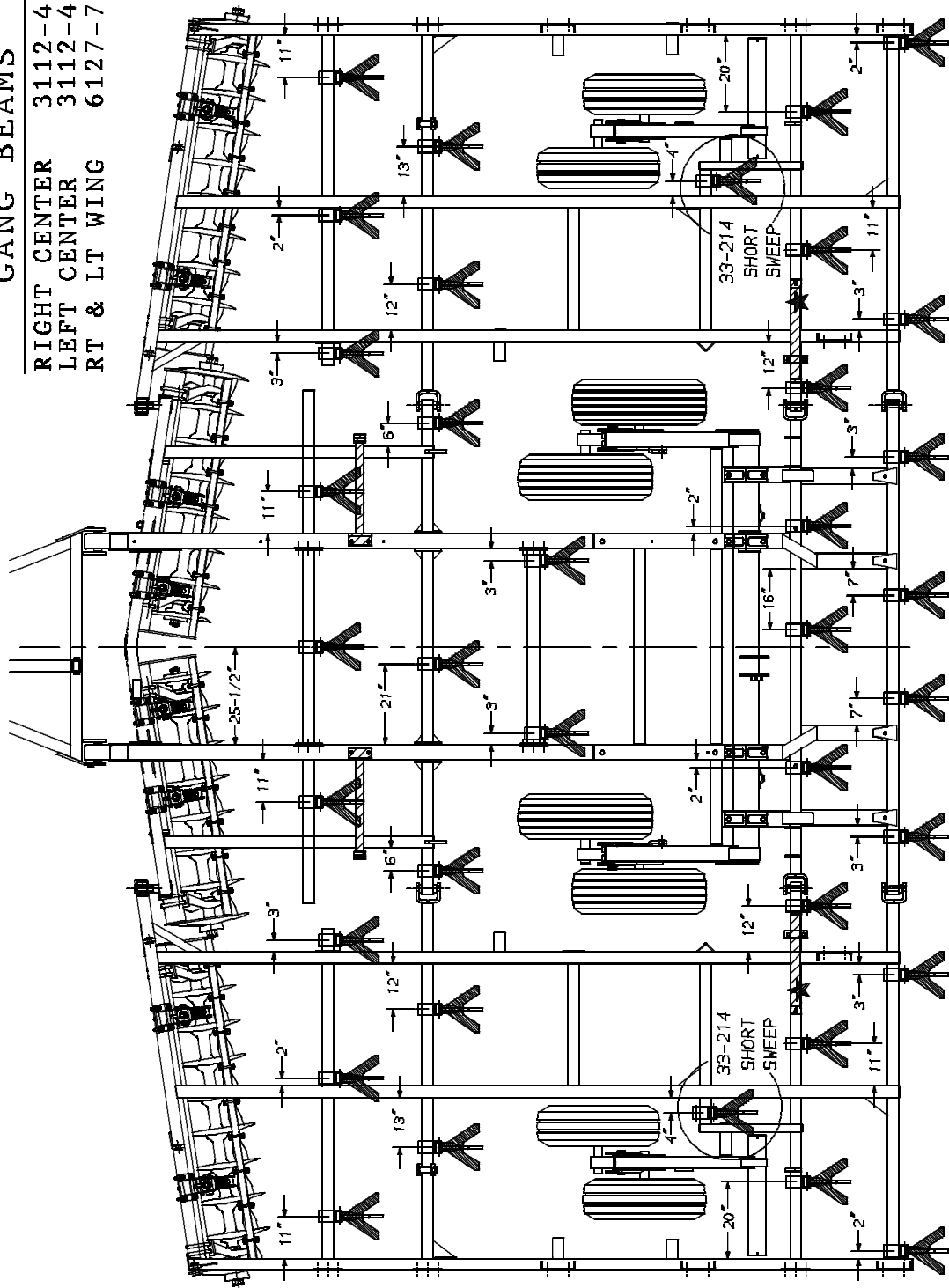

MODEL TL 6200-31

7" SPACING UNIT SPRING SHANKS

TIE RODS

RT & LT CENTER	2212-18-1
RT & LT WING	(2) 2146-82-1

GANG BEAMS

RIGHT CENTER	3112-46-0
LEFT CENTER	3112-47-0
RT & LT WING INSIDE	6131-48-0
RT WING OUTSIDE	6131-46-0
LT WING OUTSIDE	6131-47-0

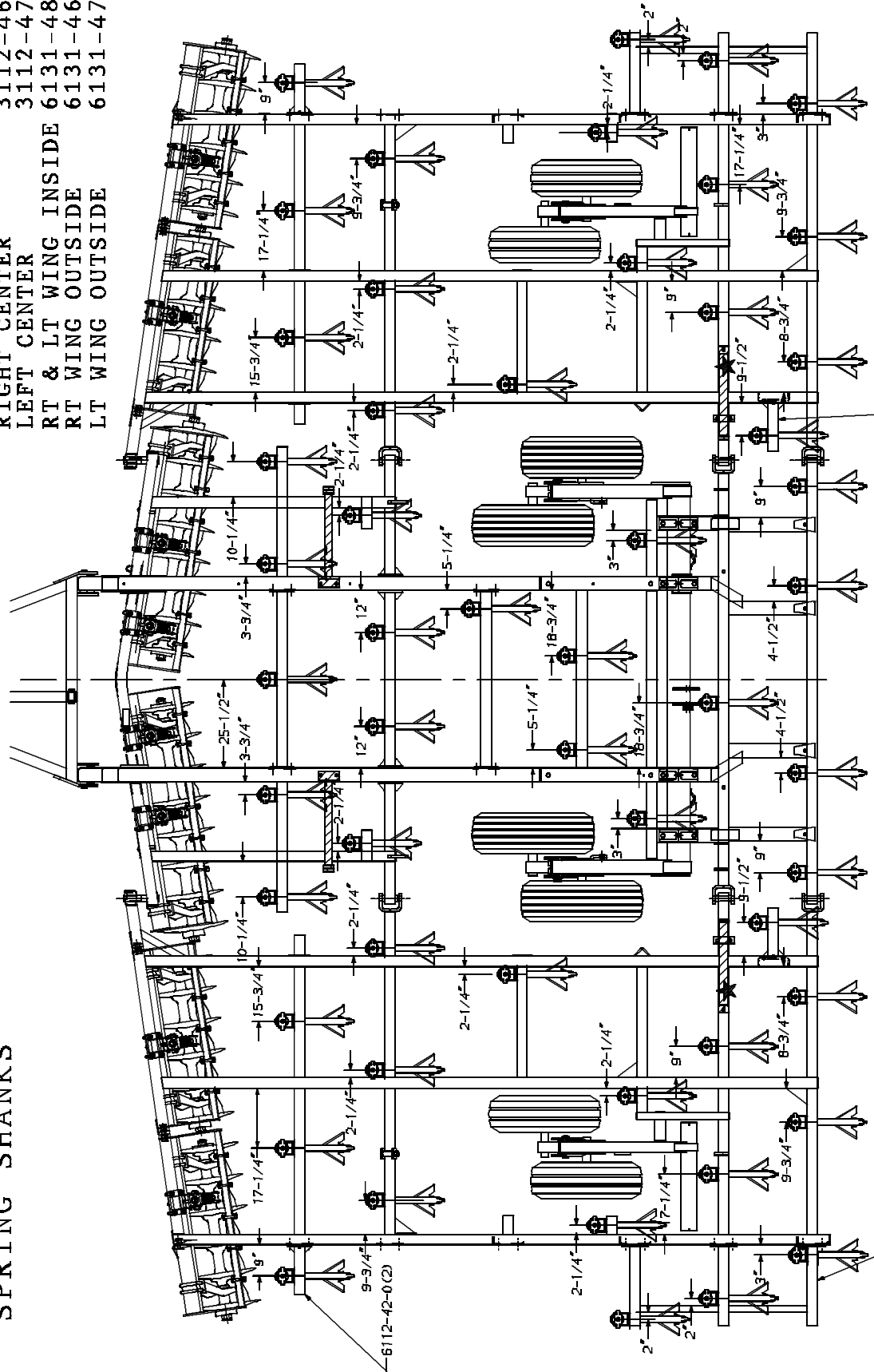

MODEL TL 6200-31

7" SPACING UNIT
2-PC K-TINE SHANKS

TIE RODS

RT & LT CENTER	2212-18-1
RT & LT WING	(2) 2146-82-1

GANG BEAMS

RIGHT CENTER	3112-46-0
LEFT CENTER	3112-47-0
RT & LT WING INSIDE	6131-48-0
RT WING OUTSIDE	6131-46-0
LT WING OUTSIDE	6131-47-0

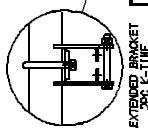
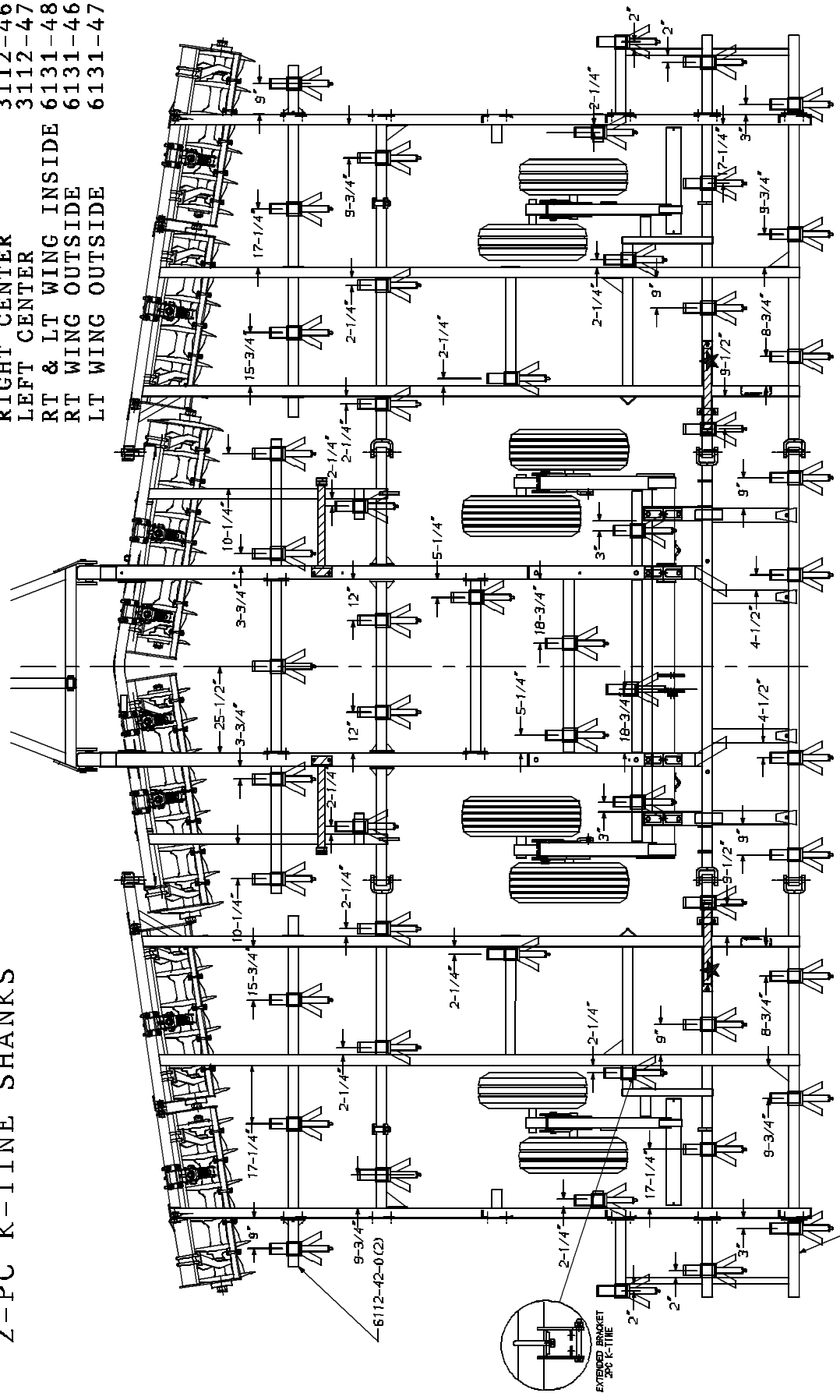

MODEL TL 6200-31

9" SPACING UNIT
2-PC K-TINE SHANKS

TIE RODS

RT & LT CENTER	2212-18-1
RT & LT WING	(2) 2146-82-1

GANG BEAMS

RIGHT CENTER	3112-46-0
LEFT CENTER	3112-47-0
RT & LT WING INSIDE	6131-48-0
RT WING OUTSIDE	6131-46-0
LT WING OUTSIDE	6131-47-0

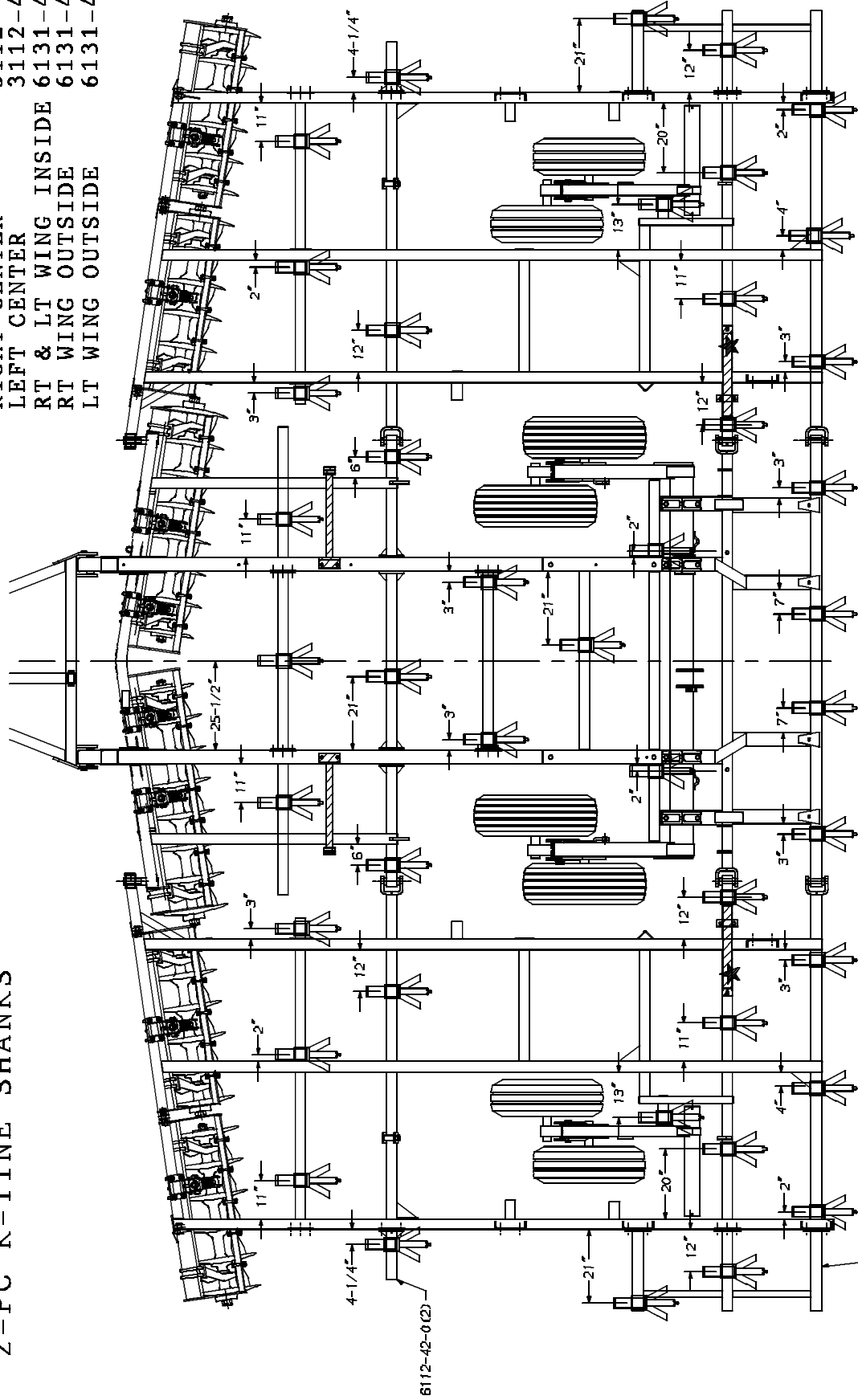

MODEL TL 6200-31

9" SPACING UNIT
XT 270 SHANKS

TIE RODS

RT & LT CENTER	2212-18-1
RT & LT WING	(2) 2146-82-1

GANG BEAMS

RIGHT CENTER	3112-46-0
LEFT CENTER	3112-47-0
RT & LT WING INSIDE	6131-48-0
RT WING OUTSIDE	6131-46-0
LT WING OUTSIDE	6131-47-0

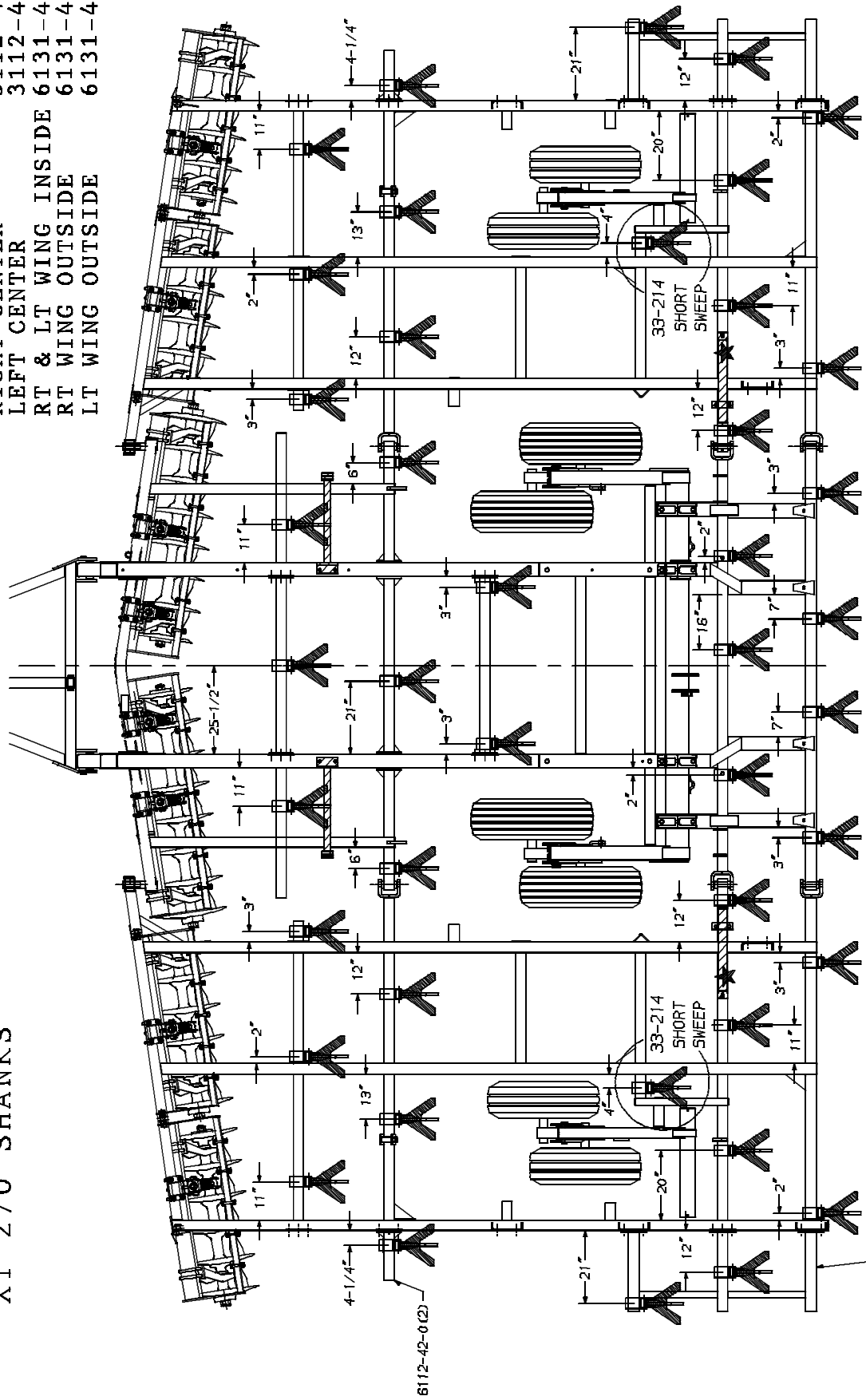

MODEL TL 6200-36

7" SPACING UNIT
 SPRING SHANKS

NOTE: SEE PAGE P82 FOR GANG CYLINDER LOCATION

CYLINDER SHOULD BE MOUNTED
 AS CLOSE TO FRAME MEMBER
 "A" AS POSSIBLE TO ALLOW
 CLEARANCE WHEN FOLDING
 2 PLACES

(2) SPRING SHANK ADAPTER
 SPACE THE SHANK FORWARD

TIE RODS

RT & LT CENTER	2212-18-1
RT & LT INNER WING	2212-18-1
RT & LT OUTER WING	2136-82-1

GANG BEAMS

RIGHT CENTER	3112-46-0
LEFT CENTER	3112-47-0
RT INNER WING	3112-46-0
LT INNER WING	3112-47-0
RT OUTER WING	6121-48-0
LT OUTER WING	6121-49-0

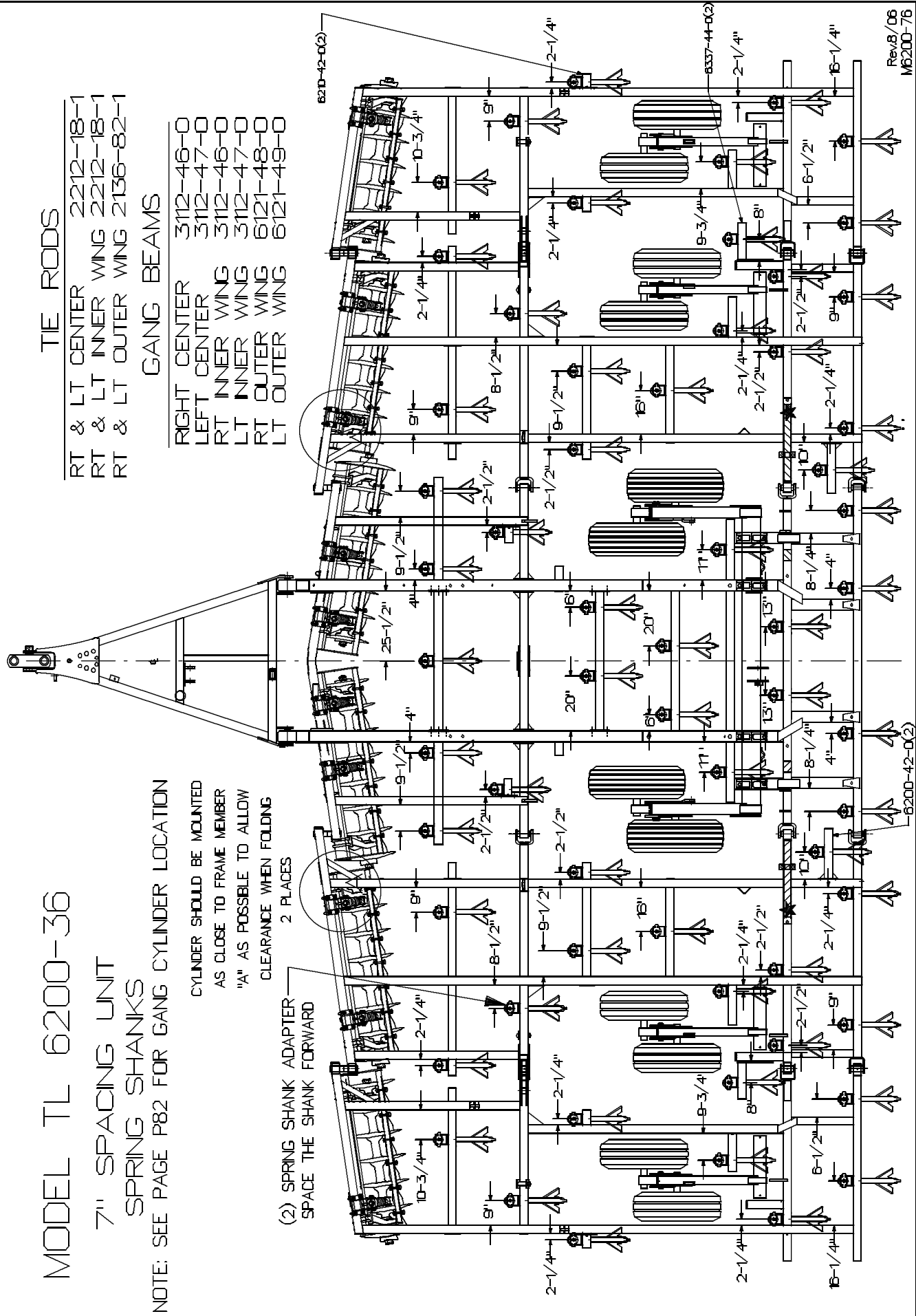

Rev 8/06
 M6200-76

MODEL TL 6200-36

7" SPACING UNIT 2-PC K-TINE SHANKS

NOTE: SEE PAGE P82 FOR GANG CYLINDER LOCATION

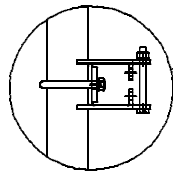

EXTENDED BRACKET
2-PC K-TINE

CYLINDER SHOULD BE MOUNTED
AS CLOSE TO FRAME MEMBER
"A" AS POSSIBLE TO ALLOW
CLEARANCE WHEN FOLDING
2 PLACES

TIE RODS

RT & LT CENTER	2212-18-1
RT & LT INNER WING	2212-18-1
RT & LT OUTER WING	2136-82-1

GANG BEAMS

RIGHT CENTER	3112-46-0
LEFT CENTER	3112-47-0
RT INNER WING	3112-46-0
LT INNER WING	3112-47-0
RT OUTER WING	6121-48-0
LT OUTER WING	6121-49-0

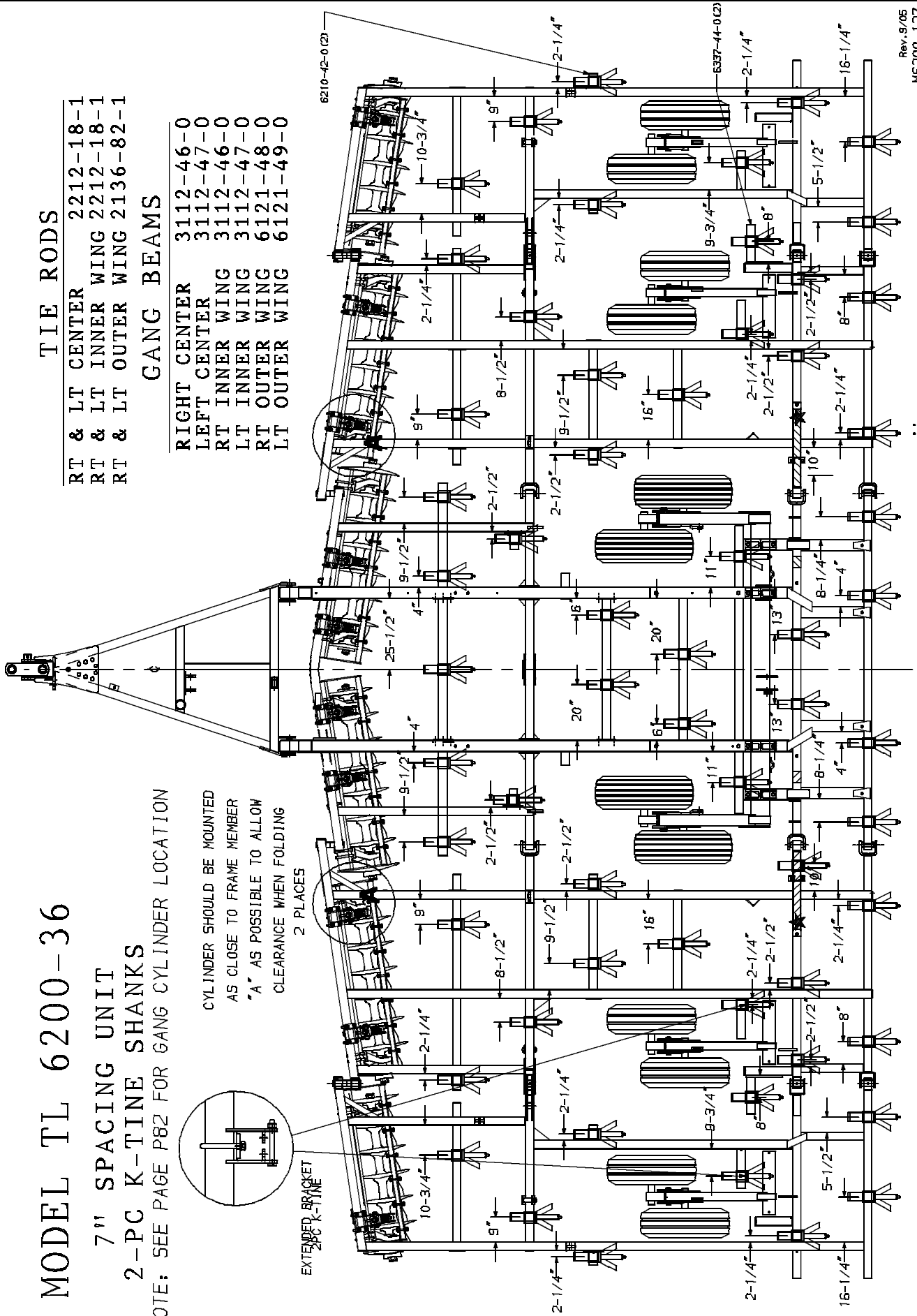

MODEL TL 6200-36

9" SPACING UNIT

Note: See Page P82 for Gang Cylinder Location

TIE RODS

RT & LT CENTER	2212-18-1
RT & LT INNER WING	2212-18-1
RT & LT OUTER WING	2136-82-1

GANG BEAMS

RIGHT CENTER	3112-46-0
LEFT CENTER	3112-47-0
RT INNER WING	3112-46-0
LT INNER WING	3112-47-0
RT OUTER WING	6121-48-0
LT OUTER WING	6121-49-0

CYLINDER SHOULD BE MOUNTED AS CLOSE TO FRAME MEMBER "A" AS POSSIBLE TO ALLOW CLEARANCE WHEN FOLDING 2 PLACES

(2) SPRING SHANK ADAPTER SPACE THE SHANK FORWARD

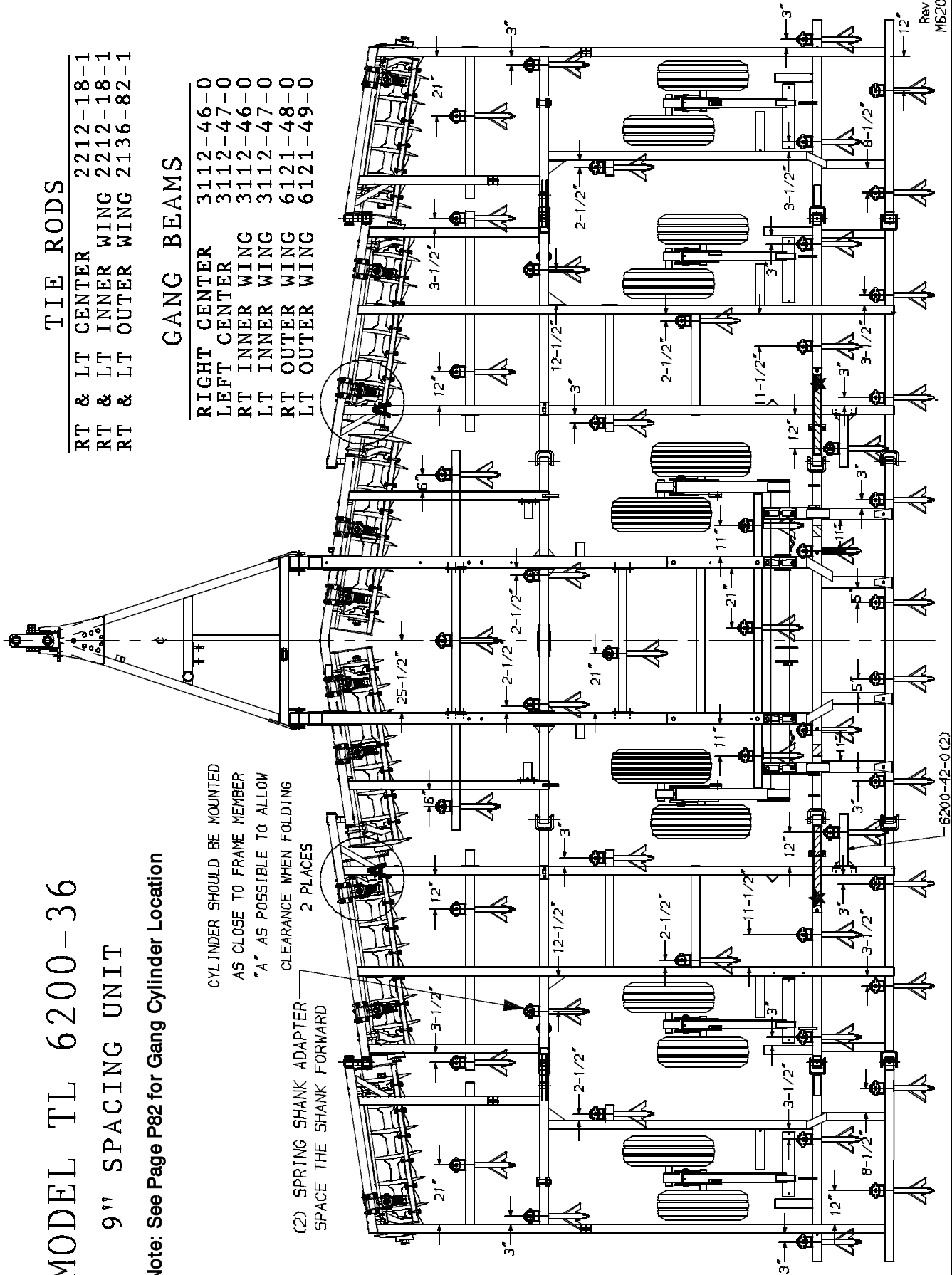

Rev. 9/05
M6200-77

MODEL TL 6200-36

9" SPACING UNIT

2-PC K-TINE SHANKS

Note: See Page P82 for Gang Cylinder Location

CYLINDER SHOULD BE MOUNTED
AS CLOSE TO FRAME MEMBER
"A" AS POSSIBLE TO ALLOW
CLEARANCE WHEN FOLDING
2 PLACES

TIE RODS	
RT & LT CENTER	2212-18-1
RT & LT INNER WING	2212-18-1
RT & LT OUTER WING	2136-82-1

GANG BEAMS	
RIGHT CENTER	3112-46-0
LEFT CENTER	3112-47-0
RT INNER WING	3112-46-0
LT INNER WING	3112-47-0
RT OUTER WING	6121-48-0
LT OUTER WING	6121-49-0

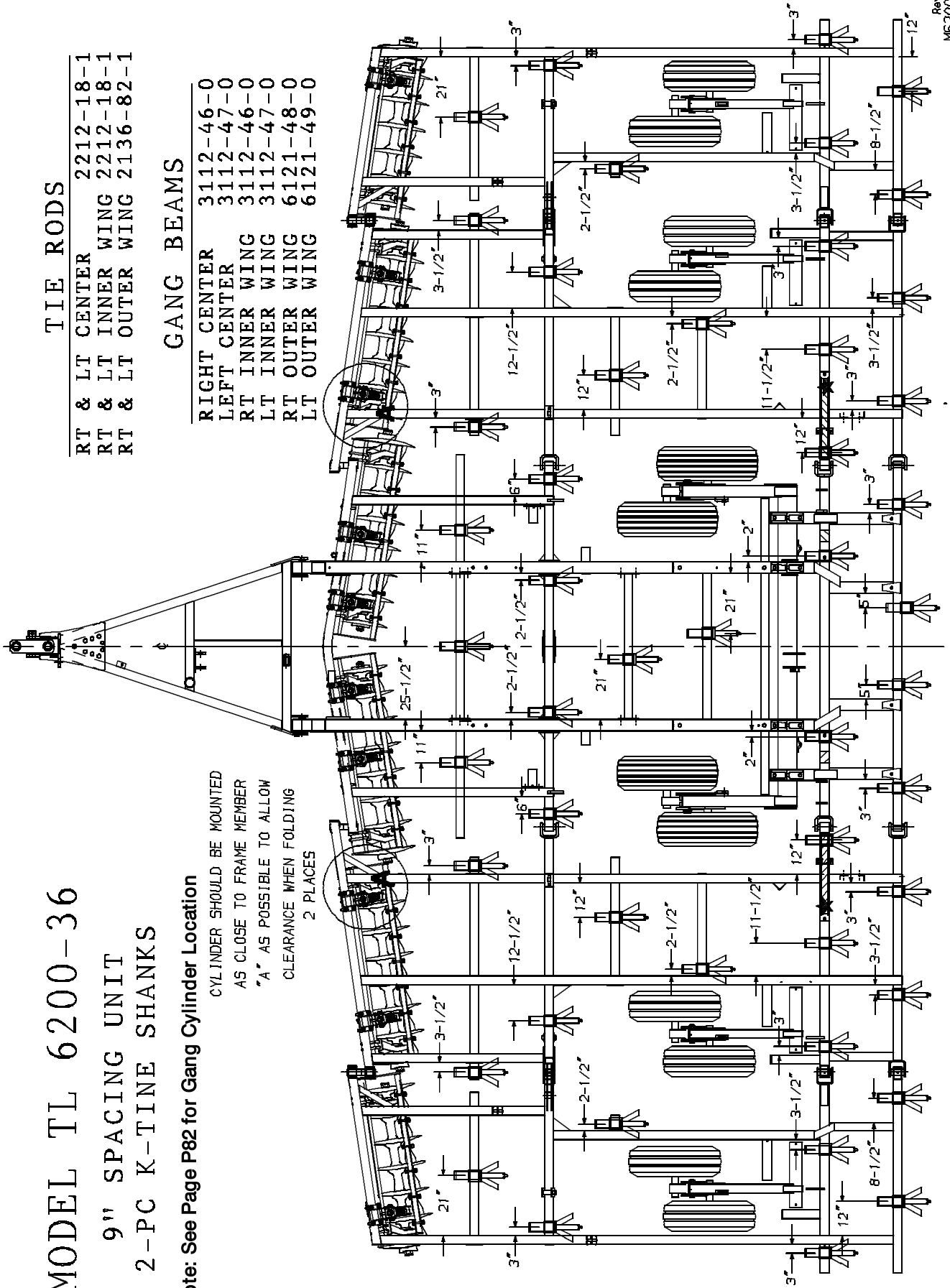

MODEL TL 6200-42

7" SPACING UNIT
SPRING SHANKS

TIE RODS

RT & LT CENTER	2212-18-1
RT & LT INNER WING	2228-18-1
RT & LT OUTER WING	2224-18-1

GANG BEAMS

RIGHT CENTER	3112-46-0
LEFT CENTER	3112-47-0
RT INNER WING	6345-70-0
LT INNER WING	6345-70-0
RT OUTER WING	6345-80-0
LT OUTER WING	6345-81-0

NOTE: SEE PAGE P83 FOR GANG CYLINDER LOCATION

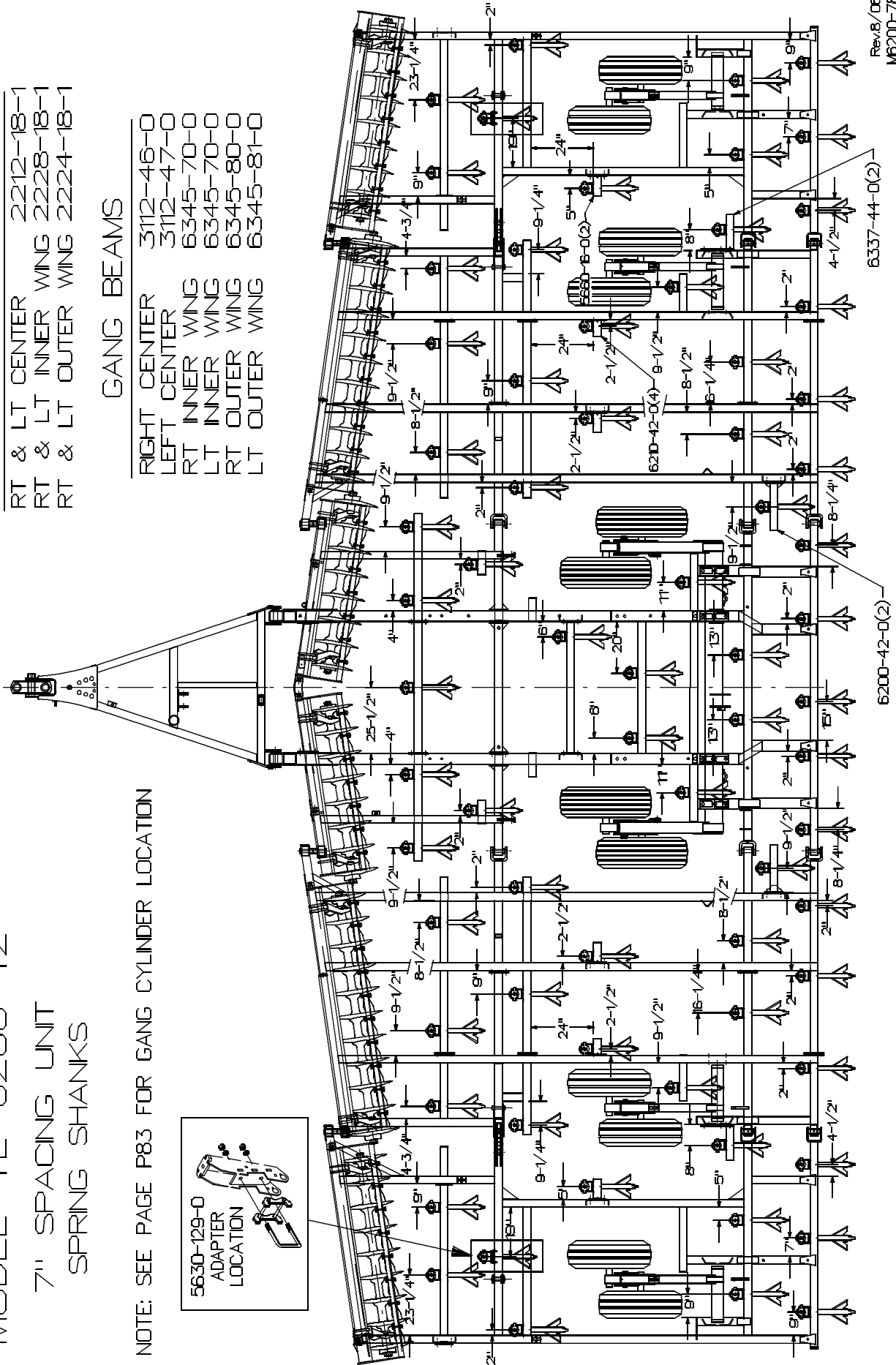
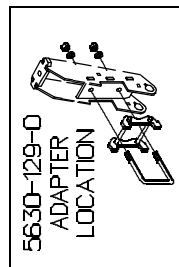

Rev.8/06
M6200-78

6200-42-0(2)

6337-44-0(2)

MODEL TL 6200-42

9" SPACING UNIT
 SPRING SHANKS

TIE RODS

RT & LT CENTER	2212-18-1
RT & LT INNER WING	2228-18-1
RT & LT OUTER WING	2224-18-1

GANG BEAMS

RIGHT CENTER	3112-46-0
LEFT CENTER	3112-47-0
RT INNER WING	6345-70-0
LT INNER WING	6345-70-0
RT OUTER WING	6345-80-0
LT OUTER WING	6345-81-0

NOTE: SEE PAGE P88 FOR GANG CYLINDER LOCATION

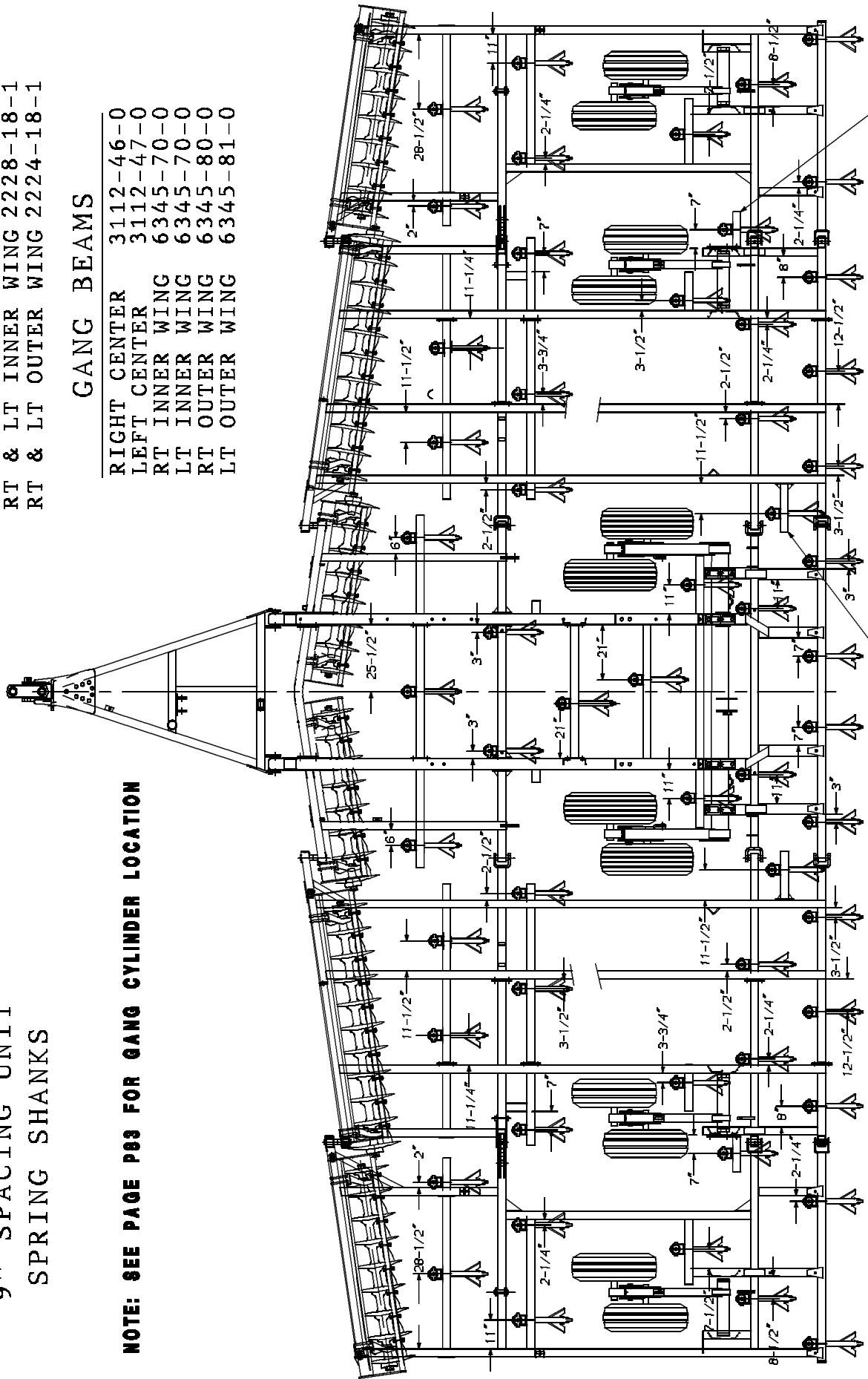

Rev. 9/05
 M6200-79

MODEL TL 6200-42
 9" SPACING UNIT
 2-PC K-TINE SHANKS

TIE RODS

RT & LT CENTER	2212-18-1
RT & LT INNER WING	2227-18-1
RT & LT OUTER WING	2224-18-1

GANG BEAMS

RIGHT CENTER	3112-46-0
LEFT CENTER	3112-47-0
RT INNER WING	6345-70-0
LT INNER WING	6345-70-0
RT OUTER WING	6345-80-0
LT OUTER WING	6345-81-0

NOTE: SEE PAGE P83 FOR GANG CYLINDER LOCATION

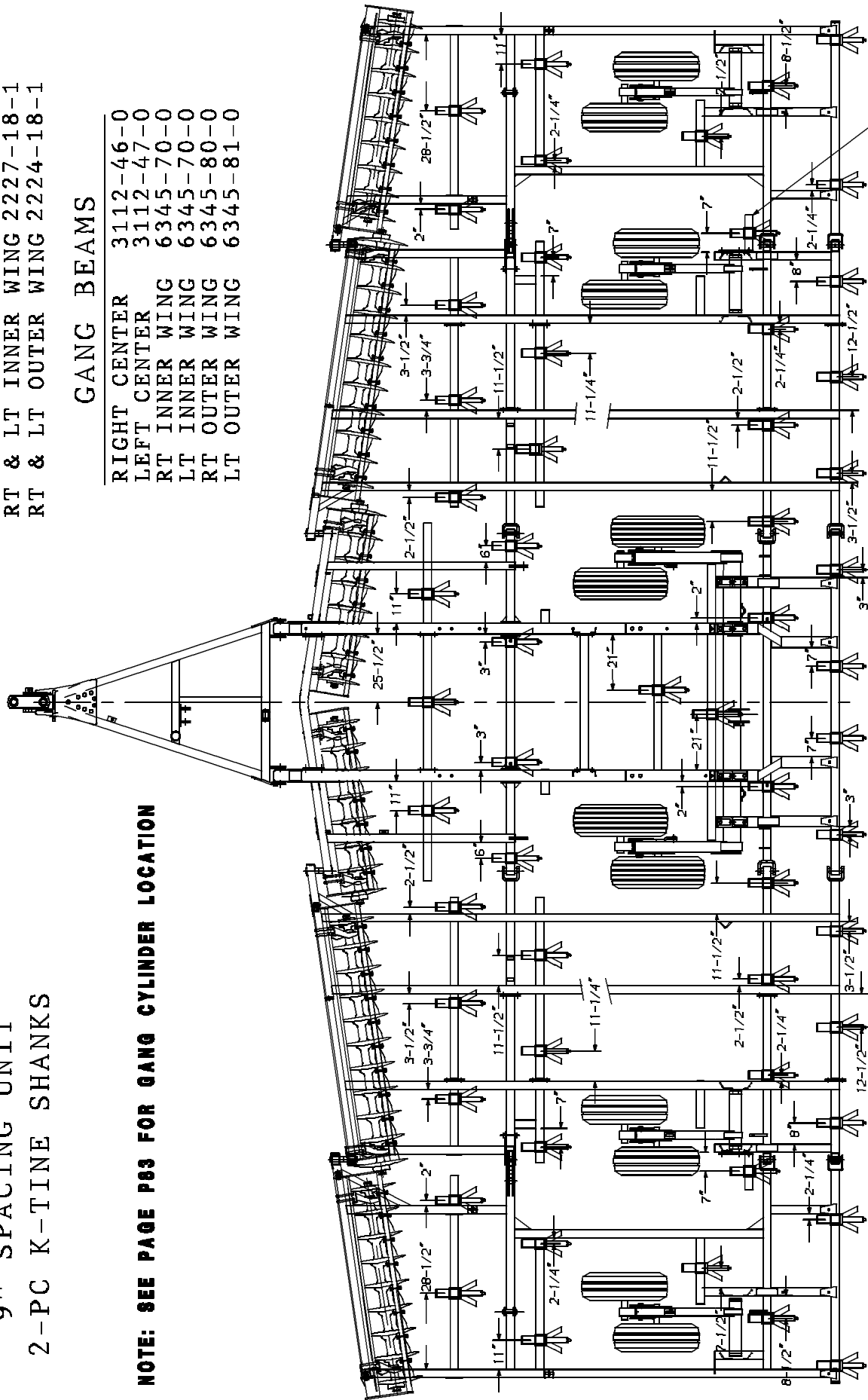

MODEL TL 6200-42
9" SPACING UNIT
XT 270 SHANKS

TIE RODS

RT & LT CENTER	2212-18-1
RT & LT INNER WING	2227-18-1
RT & LT OUTER WING	2224-18-1

GANG BEAMS

RIGHT CENTER	3112-46-0
LEFT CENTER	3112-47-0
RT INNER WING	6345-70-0
LT INNER WING	6345-70-0
RT OUTER WING	6345-80-0
LT OUTER WING	6345-81-0

NOTE: SEE PAGE P63 FOR GANG CYLINDER LOCATION

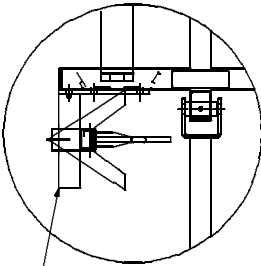

RELOCATE FOR XT

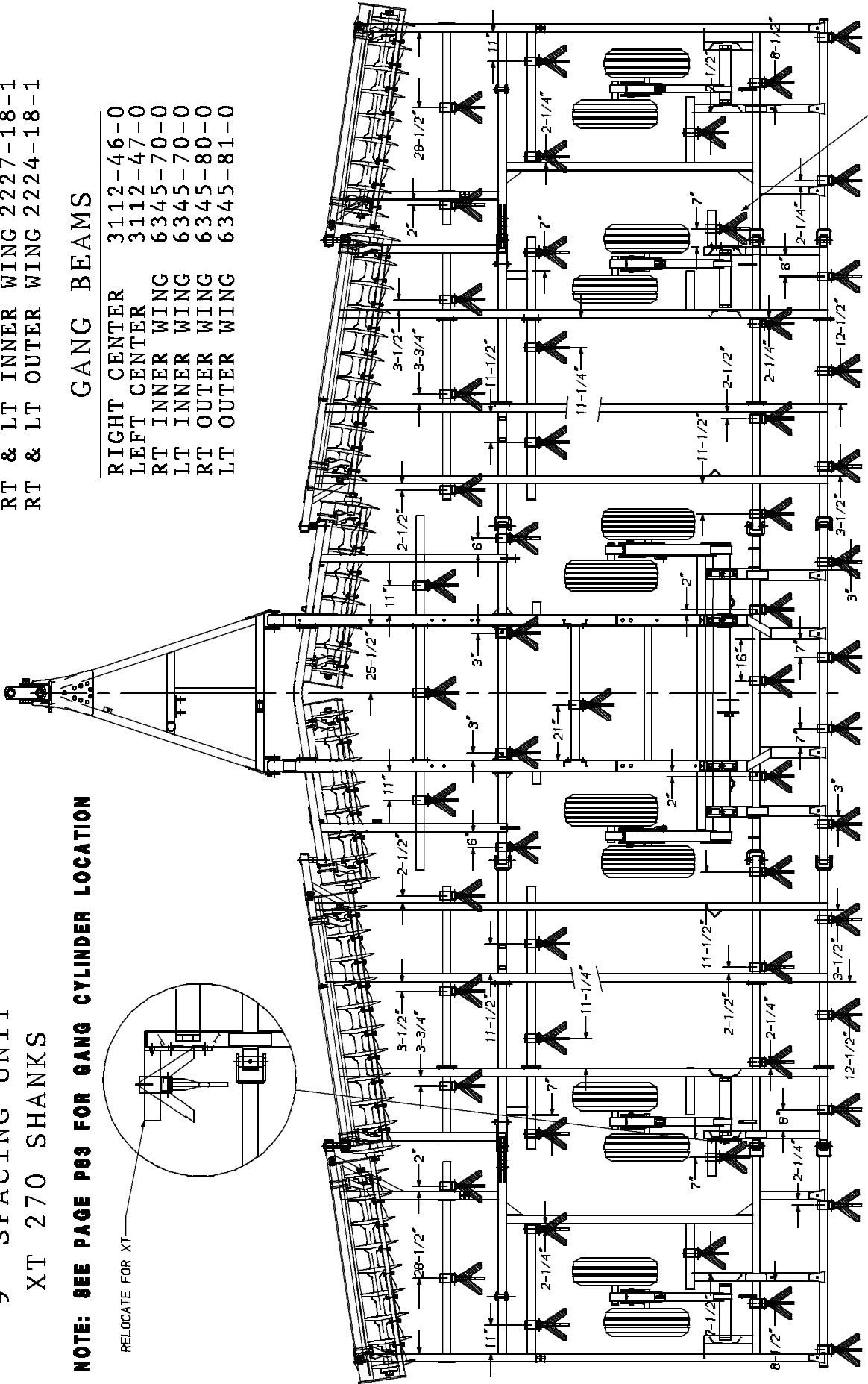

MODEL TL 6200-45

7" SPACING UNIT SPRING SHANKS

TIE RODS

RT & LT CENTER	2212-18-1
RT & LT INNER WING	2228-18-1
RT & LT OUTER WING	2225-18-1

GANG BEAMS

RIGHT CENTER	3112-46-0
LEFT CENTER	3112-47-0
RT INNER WING	6345-70-0
LT INNER WING	6345-70-0
RT OUTER WING	6210-80-0
LT OUTER WING	6210-81-0

NOTE: SEE PAGE P83 FOR GANG CYLINDER LOCATION

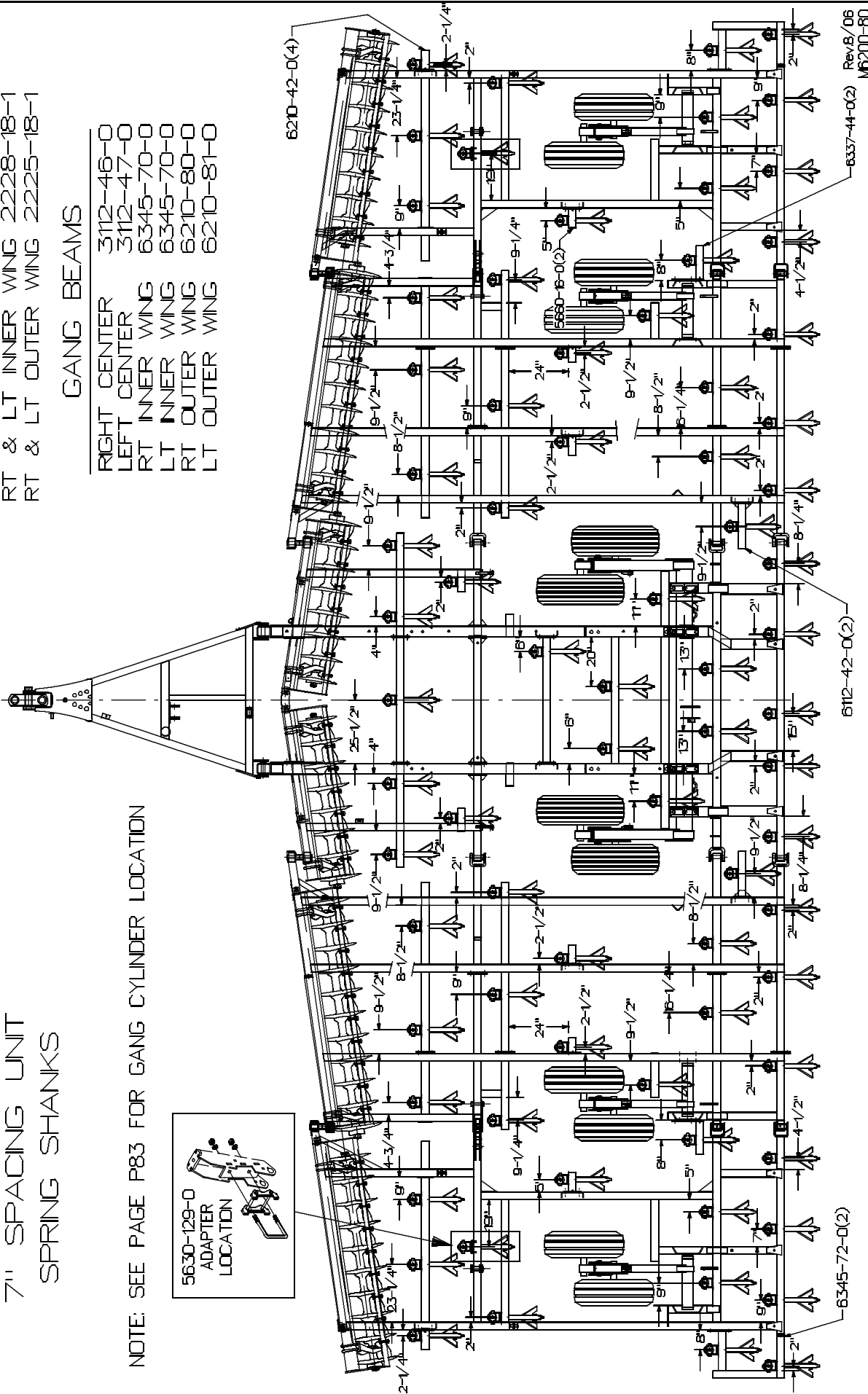
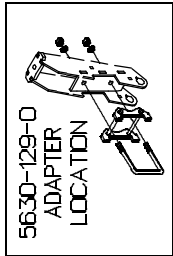

MODEL TL 6200-45

7" SPACING UNIT
2-PC K-TINE SHANKS

**NOTE: SEE PAGE P83 FOR GANG CYLINDER LOCATION
EXTENDED BRACKET - BOTH SIDES
2PC K-TINE**

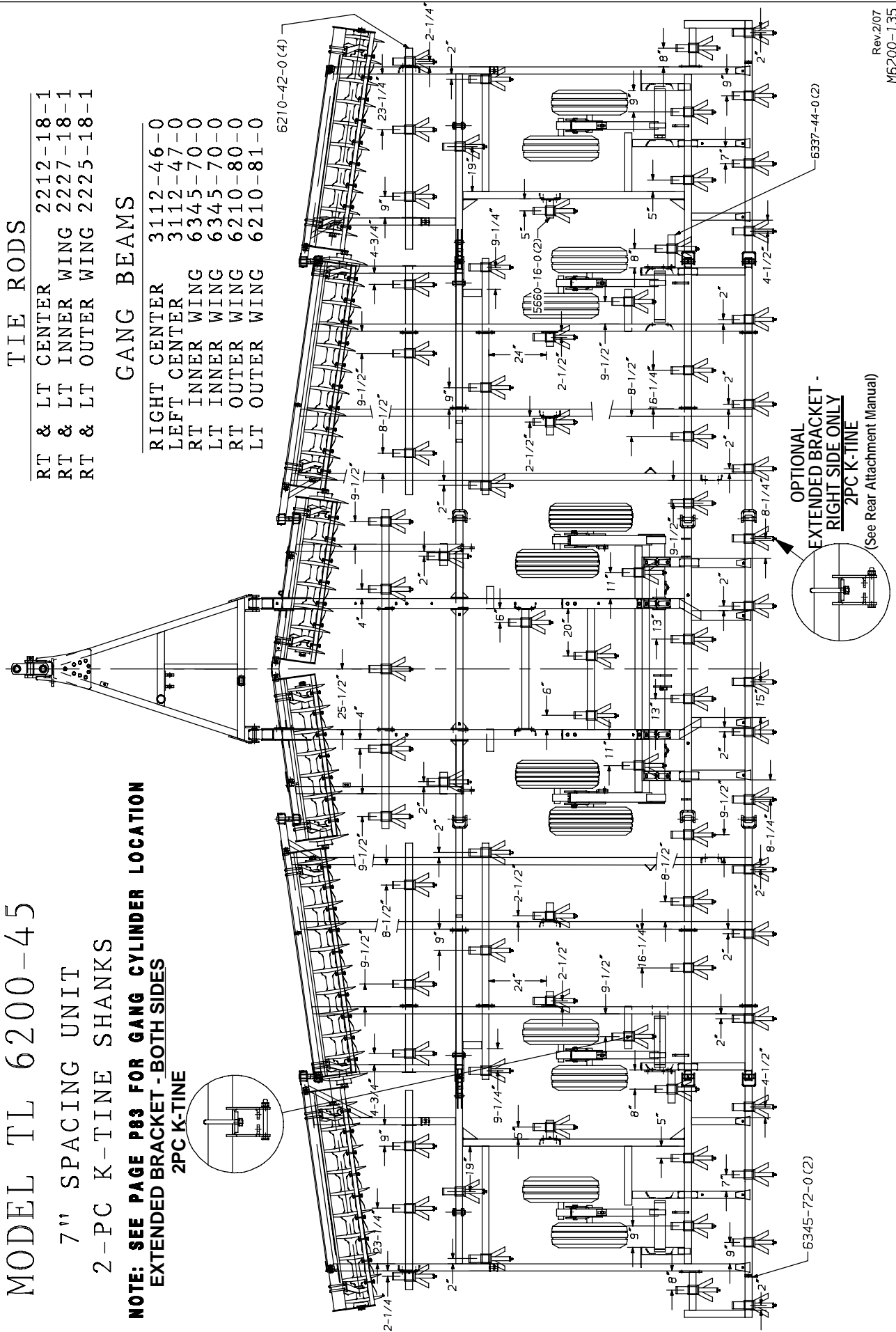

TIE RODS	
RT & LT CENTER	2212-18-1
RT & LT INNER WING	2227-18-1
RT & LT OUTER WING	2225-18-1

GANG BEAMS	
RIGHT CENTER	3112-46-0
LEFT CENTER	3112-47-0
RT INNER WING	6345-70-0
LT INNER WING	6345-70-0
RT OUTER WING	6210-80-0
LT OUTER WING	6210-81-0



6337-44-0 (2)

6345-72-0 (2)

MODEL TL 6200-45

9" SPACING UNIT SPRING SHANKS

TIE RODS

RT & LT CENTER	2212-18-1
RT & LT INNER WING	2228-18-1
RT & LT OUTER WING	2225-18-1

GANG BEAMS

RIGHT CENTER	3112-46-0
LEFT CENTER	3112-47-0
RT INNER WING	6345-70-0
LT INNER WING	6345-70-0
RT OUTER WING	6210-80-0
LT OUTER WING	6210-81-0

NOTE: SEE PAGE P83 FOR GANG CYLINDER LOCATION

